

---

# **magicolor 1690MF Printer / Copier / Scanner User's Guide**

---

**A0HF-9571-00A**

---

## Thank You

Thank you for purchasing a magicolor 1690MF. You have made an excellent choice. Your magicolor 1690MF is specially designed for optimal performance in Windows and Macintosh environments.

## Trademarks

KONICA MINOLTA and the KONICA MINOLTA logo are trademarks or registered trademarks of KONICA MINOLTA HOLDINGS, INC.

magicolor and PageScope are trademarks or registered trademarks of KONICA MINOLTA BUSINESS TECHNOLOGIES, INC.

All other trademarks and registered trademarks are the property of their respective owners.

## Copyright Notice

Copyright © 2008 KONICA MINOLTA BUSINESS TECHNOLOGIES, INC., Marunouchi Center Building, 1-6-1 Marunouchi, Chiyoda-ku, Tokyo, 100-0005, Japan. All Rights Reserved. This document may not be copied, in whole or part, nor transferred to any other media or language, without written permission of KONICA MINOLTA BUSINESS TECHNOLOGIES, INC.

## Notice

KONICA MINOLTA BUSINESS TECHNOLOGIES, INC. reserves the right to make changes to this guide and to the equipment described herein without notice. Considerable effort has been made to ensure that this guide is free of inaccuracies and omissions. However, KONICA MINOLTA BUSINESS TECHNOLOGIES, INC. makes no warranty of any kind including, but not limited to, any implied warranties of merchantability and fitness for a particular purpose with regard to this guide.

KONICA MINOLTA BUSINESS TECHNOLOGIES, INC. assumes no responsibility for, or liability for, errors contained in this guide or for incidental, special, or consequential damages arising out of the furnishing of this guide, or the use of this guide in operating the equipment, or in connection with the performance of the equipment when so operated.

# SOFTWARE LICENSE AGREEMENT

This package contains the following materials provided by KONICA MINOLTA BUSINESS TECHNOLOGIES, INC. (KMBT): software included as part of the printing system ("Printing Software"), the digitally-encoded machine-readable outline data encoded in the special format and in the encrypted form ("Font Programs"), other software which runs on a computer system for use in conjunction with the Printing Software ("Host Software"), and related explanatory written materials ("Documentation"). The term "Software" shall be used to describe Printing Software, Font Programs and/or Host Software and also include any upgrades, modified versions, additions, and copies of the Software.

The Software is being licensed to you under the terms of this Agreement.

KMBT grants to you a non-exclusive sublicense to use the Software and Documentation, provided that you agree to the following:

1. You may use the Software and accompanying Font Programs for imaging to the licensed output device(s), solely for your own internal business purposes.
2. In addition to the license for Font Programs set forth in Section 1 above, you may use Roman Font Programs to reproduce weights, styles, and versions of letters, numerals, characters and symbols ("Typefaces") on the display or monitor for your own internal business purposes.
3. You may make one backup copy of the Host Software, provided your backup copy is not installed or used on any computer. Notwithstanding the above restrictions, you may install the Host Software on any number of computers solely for use with one or more printing systems running the Printing Software.
4. You may assign its rights under this Agreement to an assignee of all of Licensee's right and interest to such Software and Documentation ("Assignee") provided you transfer to Assignee all copies of such Software and Documentation Assignee agrees to be bound by all of the terms and conditions of this Agreement.
5. You agree not to modify, adapt or translate the Software and Documentation.
6. You agree that you will not attempt to alter, disassemble, decrypt, reverse engineer or decompile the Software.
7. Title to and ownership of the Software and Documentation and any reproductions thereof shall remain with KMBT and its licensor.
8. Trademarks shall be used in accordance with accepted trademark practice, including identification of the trademark owner's name. Trademarks can only be used to identify printed output produced by the Software. Such use of any trademark does not give you any rights of ownership in that trademark.
9. You may not rent, lease, sublicense, lend or transfer versions or copies of the Software Licensee does not use, or Software contained on any unused media, except as part of the permanent transfer of all Software and Documentation as described above.
10. IN NO EVENT WILL KMBT OR ITS LICENSOR BE LIABLE TO YOU FOR ANY CONSEQUENTIAL, INCIDENTAL INDIRECT, PUNITIVE OR SPECIAL DAMAGES, INCLUDING ANY LOST PROFITS OR LOST SAVING, EVEN IF KMBT HAS BEEN ADVISED OF THE POSSIBILITY OF SUCH DAMAGES, OR FOR ANY CLAIM BY ANY THIRD PARTY. KMBT OR ITS LICENSOR DISCLAIMS ALL WARRANTIES WITH REGARD TO THE SOFTWARE, EXPRESS OR IMPLIED, INCLUDING, WITHOUT LIMITATION IMPLIED WARRANTIES OF MERCHANTABILITY, FITNESS FOR A PARTICULAR PURPOSE, TITLE AND NON-INFRINGEMENT OF THIRD PARTY RIGHTS. SOME STATES OR JURISDICTIONS DO NOT ALLOW THE EXCLUSION OR LIMITATION OF INCIDENTAL, CONSEQUENTIAL OR SPECIAL DAMAGES, SO THE ABOVE LIMITATIONS MAY NOT APPLY TO YOU.

11. Notice to Government End Users: The Software is a “commercial item,” as that term is defined at 48 C.F.R.2.101, consisting of “commercial computer software” and “commercial computer software documentation,” as such terms are used in 48 C.F.R. 12.212. Consistent with 48 C.F.R. 12.212 and 48 C.F.R. 227.7202-1 through 227.7202-4, all U.S. Government End Users acquire the Software with only those rights set forth herein.
12. You agree that you will not export the Software in any form in violation of any applicable laws and regulations regarding export control of any countries.

# Legal Restrictions on Copying

Certain types of documents must never be copied with the purpose or intent to pass copies of such documents off as the originals.

The following is not a complete list, but is meant to be used as a guide to responsible copying.

## Financial Instruments

- Personal checks
- Traveler's checks
- Money orders
- Certificates of deposit
- Bonds or other certificates of indebtedness
- Stock certificates

## Legal Documents

- Food stamps
- Postage stamps (canceled or uncanceled)
- Checks or drafts drawn by government agencies
- Internal revenue stamps (canceled or uncanceled)
- Passports
- Immigration papers
- Motor vehicle licenses and titles
- House and property titles and deeds

## General

- Identification cards, badges, or insignias
- Copyrighted works without permission of the copyright owner

In addition, it is prohibited under any circumstances to copy domestic or foreign currencies, or works of art without permission of the copyright owner.

When in doubt about the nature of a document, consult with legal counsel.



*In order to prohibit the illegal reproduction of certain documents, such as paper currency, this machine is equipped with a counterfeit prevention feature.*

*Due to the counterfeit prevention feature that this machine is equipped with, images may be distorted.*

## For EU member states only

This symbol means: **Do not dispose of this product together with your household waste!**

Please contact the Local Authority for appropriate disposal instructions. In the case of a new device being purchased, the used one can also be given to our dealer for appropriate disposal. Recycling of this product will help to conserve natural resources and prevent potential negative consequences for the environment and human health caused by inappropriate waste handling.

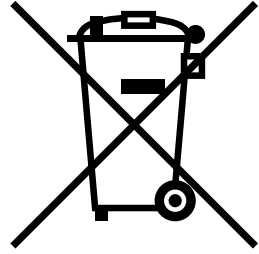

This product complies with RoHS (2002/95/EC) directive.

---

# Contents

---

<b>1 Introduction .....</b>	<b>1-1</b>
<b>Getting Acquainted with Your Machine .....</b>	<b>1-2</b>
Space Requirements.....	1-2
Part Names .....	1-5
Front View.....	1-5
Rear View .....	1-6
Front View with Options .....	1-7
Rear View with Options.....	1-8
Drivers CD/DVD .....	1-10
Printer Drivers .....	1-10
Scanner Drivers .....	1-10
PC Fax Drivers.....	1-10
Applications CD/DVD .....	1-12
Applications.....	1-12
Documentation CD/DVD .....	1-13
Documentation.....	1-13
System Requirements.....	1-14

<b>2</b>	<b>Control Panel and Configuration Menu .....</b>	<b>2-1</b>
	<b>About the Control Panel .....</b>	<b>2-2</b>
	Control Panel Indicators and Keys.....	2-2
	Display Indications .....	2-5
	Main Screen (Copy Mode) .....	2-5
	Main Screen (Scan Mode) .....	2-7
	Main Screen (Fax Mode) .....	2-10
	Print Screen .....	2-13
	<b>Checking the Machine Status and Settings .....</b>	<b>2-14</b>
	PRINTER MODE Menu.....	2-14
	TONER REMAINING .....	2-15
	T/C CHANGE .....	2-15
	REPORT/STATUS Menu.....	2-17
	TOTAL PRINT.....	2-17
	SUPPLY STATUS.....	2-18
	TX/RX RESULT .....	2-18
	REPORT .....	2-18
	<b>Configuration Menu Overview .....</b>	<b>2-20</b>
	UTILITY Menu.....	2-20
	MACHINE SETTING Menu.....	2-22
	TRAY1 PAPER SETUP Menu .....	2-26
	ADMIN. MANAGEMENT Menu.....	2-28
	COPY SETTING Menu .....	2-42
	DIAL REGISTER Menu.....	2-44
	FAX TX OPERATION Menu .....	2-45
	FAX RX OPERATION Menu.....	2-47
	REPORTING Menu.....	2-50
	SCAN SETTING Menu .....	2-52
<b>3</b>	<b>Media Handling .....</b>	<b>3-1</b>
	<b>Print Media .....</b>	<b>3-2</b>
	Specifications .....	3-2
	Types .....	3-3
	Plain Paper (Recycled Paper).....	3-3
	Thick Stock .....	3-4
	Envelope .....	3-5
	Label .....	3-6
	Letterhead.....	3-7
	Postcard.....	3-7
	<b>Printable Area .....</b>	<b>3-9</b>
	Envelopes .....	3-10
	Page Margins .....	3-10
	<b>Loading Media .....</b>	<b>3-11</b>
	How do I load media? .....	3-11
	Tray 1 (Multipurpose Tray).....	3-11
	Loading Plain Paper.....	3-11



Other Media .....	3-14
Loading Envelopes .....	3-14
Loading Label Sheets/Letterheads/Postcards and Thick Stock.....	3-16
Tray 2 .....	3-19
Loading Plain Paper.....	3-19
<b>About Duplex Printing .....</b>	<b>3-22</b>
How do I aut duplex? .....	3-22
<b>Output Tray .....</b>	<b>3-24</b>
<b>Media Storage .....</b>	<b>3-25</b>
<b>Original Media .....</b>	<b>3-26</b>
Specifications .....	3-26
Documents that can be placed on the original glass .....	3-26
Documents that can be loaded into the ADF .....	3-26
<b>Loading a Document to be Copied .....</b>	<b>3-28</b>
Placing a document on the original glass.....	3-28
Loading a document into the ADF.....	3-29
<b>4 Using the Printer Driver .....</b>	<b>4-1</b>
<b>Selecting Printer Driver Options/Defaults (for Windows) .....</b>	<b>4-2</b>
<b>Uninstalling the Printer Driver (for Windows) .....</b>	<b>4-3</b>
Windows Vista/XP/Server 2003/2000 .....	4-3
<b>Displaying Printer Driver Settings .....</b>	<b>4-3</b>
Windows Vista .....	4-3
Windows XP/Server 2003.....	4-3
Windows 2000 .....	4-4
<b>Printer Driver Settings .....</b>	<b>4-5</b>
Common Buttons .....	4-5
Basic Tab .....	4-6
Layout Tab .....	4-7
Overlay Tab.....	4-7
Watermark Tab .....	4-7
Quality Tab.....	4-7
Version Tab.....	4-8
<b>5 Using the Copier .....</b>	<b>5-1</b>
<b>Making Basic Copies .....</b>	<b>5-2</b>
Basic Copy Operation .....	5-2
Specifying the Copy Quality Setting.....	5-3
Selecting the Document Type .....	5-3
Specifying the Copy Density .....	5-4
Specifying the Zoom Ratio .....	5-4
Selecting a Preset Zoom Ratio .....	5-4
Specifying a Custom Zoom Ratio .....	5-4
Selecting the Media Tray .....	5-5

<b>Making Advanced Copies .....</b>	<b>5-6</b>
Setting 2in1 Copying .....	5-6
2in1 Copying From the ADF .....	5-6
2in1 Copying From the Original Glass .....	5-6
Setting a Copy Function .....	5-7
ID Card Copying .....	5-8
Repeat Copying .....	5-9
Poster Copying .....	5-10
Setting Duplex (Double-Sided) Copying .....	5-11
Duplex (Double-Sided) Copying From the ADF .....	5-11
Duplex (Double-Sided) Copying From the Original Glass .....	5-12
Setting Collated (Sort) Copying .....	5-13
Collated (Sort) Copying From the ADF .....	5-13
Collated (Sort) Copying From the Original Glass .....	5-13
<b>6 Using the Scanner .....</b>	<b>6-1</b>
<b>Scanning From a Computer Application .....</b>	<b>6-2</b>
Basic Scanning Operation .....	6-2
Windows TWAIN Driver Settings .....	6-3
Windows WIA Driver Settings .....	6-5
Macintosh TWAIN Driver Settings .....	6-6
<b>Scanning With the Machine .....</b>	<b>6-8</b>
Basic Scanning Operation .....	6-8
Specifying the Data Location .....	6-10
Saving Data on a Computer Connected (Scan to PC) .....	6-10
Saving Data on a USB Memory Device (Scan to USB Memory) .....	6-11
Specifying the Destination Address (Scan to E-mail/FTP/SMB) .....	6-12
Directly Entering the E-mail Address .....	6-12
Selecting From the Favorite List .....	6-13
Selecting a Speed Dial Destination .....	6-13
Selecting a Group Dial Destination .....	6-14
Selecting From the Address Book .....	6-15
Searching the Address Book .....	6-15
Searching an LDAP Server .....	6-16
Specifying Multiple Destination Addresses .....	6-18
Editing a Specified Destination Address .....	6-18
Deleting a Specified Destination Address .....	6-19
Registering/Editing Addresses .....	6-19
Registering in the Favorite List .....	6-20
Deleting From the Favorite List .....	6-20
Registering Speed Dial Destinations (Direct Input) .....	6-21
Registering Speed Dial Destinations (LDAP Search) .....	6-22
Editing/Deleting Speed Dial Destinations .....	6-23
Registering Group Dial Destinations .....	6-24
Editing/Deleting Group Dial Destinations .....	6-25
Selecting the Data Format .....	6-26

Selecting the Scan Quality Setting.....	6-27
Selecting the Resolution .....	6-27
Selecting the Scan Mode .....	6-27
Selecting the Scan Density .....	6-27
Setting the Scan Size.....	6-28
Setting the Scan Color .....	6-28
Specifying the Subject.....	6-28
Deleting a Queued Transmission Job.....	6-29
<b>7 Replacing Consumables .....</b>	<b>7-1</b>
<b>Replacing Consumables .....</b>	<b>7-2</b>
About Toner Cartridges.....	7-2
Replacing a Toner Cartridge .....	7-5
Replacing All Toner Cartridges at the Same Time.....	7-10
Replacing the Imaging Cartridge.....	7-11
Replacing the Fuser Unit.....	7-15
<b>8 Maintenance .....</b>	<b>8-1</b>
<b>Maintaining the Machine .....</b>	<b>8-2</b>
<b>Cleaning the Machine .....</b>	<b>8-4</b>
Exterior.....	8-4
Media Rollers .....	8-5
Cleaning the Media Feed Roller .....	8-5
Cleaning the Media Feed Rollers for the ADF .....	8-10
Cleaning the Media Feed Rollers for Tray 2 .....	8-11
Cleaning the Media Feed Rollers for the attachment.....	8-13
Cleaning the Media Feed Rollers for the Duplex .....	8-15
Print Head Window .....	8-16
Clearing the Print Head Window .....	8-16
<b>9 Troubleshooting .....</b>	<b>9-1</b>
<b>Introduction .....</b>	<b>9-2</b>
<b>Printing a Configuration Page .....</b>	<b>9-3</b>
<b>Preventing Media Misfeeds .....</b>	<b>9-4</b>
<b>Understanding the Media Path .....</b>	<b>9-5</b>
<b>Clearing Media Misfeeds .....</b>	<b>9-5</b>
Media Misfeed Messages and Clearing Procedures.....	9-7
Clearing a Media Misfeed in the Machine.....	9-8
Clearing a Media Misfeed From Tray 1.....	9-15
Clearing a Media Misfeed in Tray 2 .....	9-16
Clearing a Media Misfeed from the ADF .....	9-19
Clearing a Media Misfeed from the Duplex Option .....	9-21
<b>Solving Problems with Media Misfeeds .....</b>	<b>9-23</b>
<b>Solving Other Problems .....</b>	<b>9-26</b>
<b>Solving Problems with Printing Quality .....</b>	<b>9-31</b>

<b>Status, Error, and Service Messages .....</b>	<b>9-37</b>
Status Messages.....	9-37
Error Messages.....	9-38
Service Messages.....	9-46
<b>10 Installing Accessories .....</b>	<b>10-1</b>
<b>Introduction .....</b>	<b>10-2</b>
<b>Tray 2 (Lower Feeder Unit) .....</b>	<b>10-3</b>
Kit Contents.....	10-3
Installing Tray 2.....	10-4
<b>Duplex Option .....</b>	<b>10-7</b>
Kit Contents.....	10-7
Installing Attachment.....	10-8
Installing the Duplex option.....	10-9
<b>A Appendix .....</b>	<b>A-1</b>
<b>Technical Specifications .....</b>	<b>A-2</b>
Consumable Life Expectancy Chart.....	A-5
User-Replaceable .....	A-5
Service-Replaceable .....	A-5
<b>Entering Text .....</b>	<b>A-6</b>
Key Operation .....	A-6
Entering Fax Numbers .....	A-6
Entering Names .....	A-7
Entering E-mail Addresses .....	A-7
Changing Input Mode.....	A-8
Inputting Example .....	A-8
Correcting Text and Input Precautions.....	A-9
<b>Our Concern for Environmental Protection .....</b>	<b>A-10</b>
What is an ENERGY STAR product? .....	A-10



*Introduction* **1**



# Getting Acquainted with Your Machine

## Space Requirements

To ensure easy operation, consumable replacement and maintenance, adhere to the recommended space requirements detailed below.

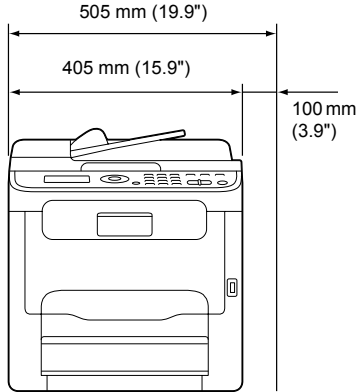

Front View

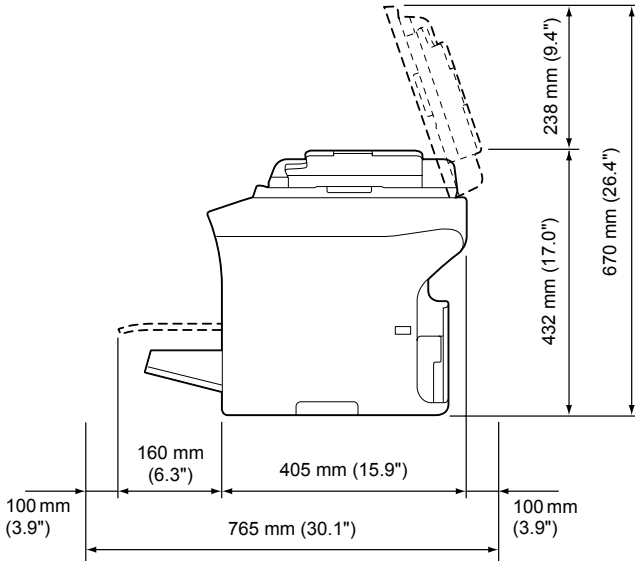

Side View

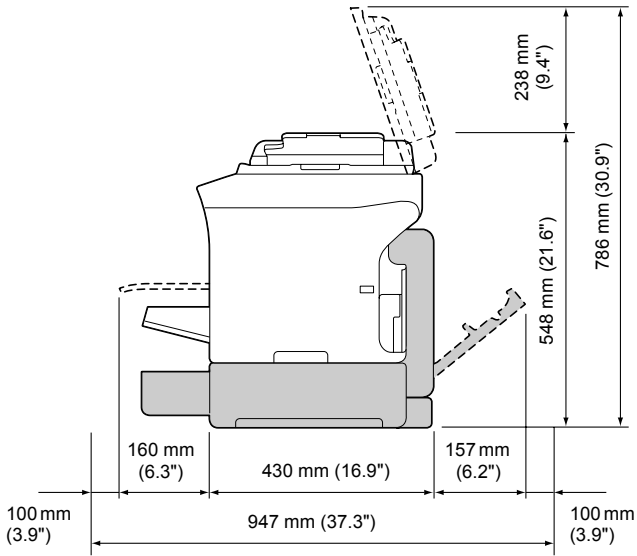

Side View with Options  
 (when Tray 2 and the duplex option are installed)



*The option appears shaded in the above illustrations.*



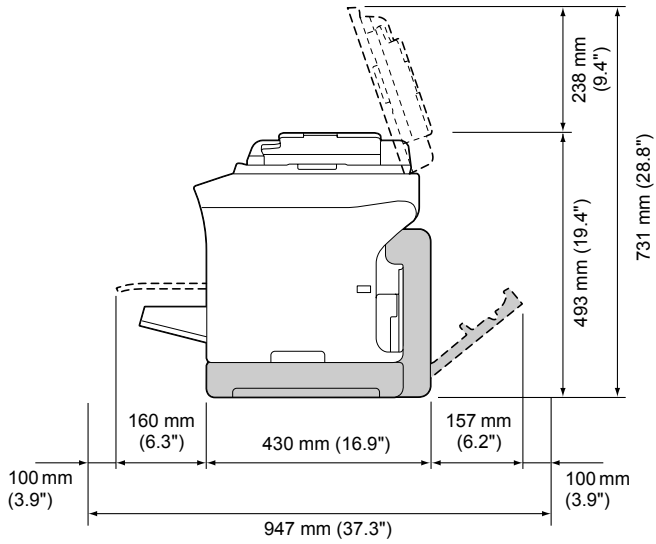

Side View with Options  
 (when the attachment and duplex option are installed)



*The option appears shaded in the above illustrations.*

## Part Names

The following drawings illustrate the parts of your machine referred to throughout this guide, so please take some time to become familiar with them.

### Front View

- 1—Control Panel
- 2—Automatic document Feeder (ADF)

- 2-a: ADF feed cover
- 2-b: Document guide
- 2-c: Document feed tray
- 2-d: Document output tray
- 2-e: Document stopper



*The ADF may appear as “document cover” in some status and error messages.*



*Lower the document stopper when scanning Legal-size paper with the ADF.*

- 3—Dust cover
- 4—Tray 1 (Manual feed tray)
- 5—Output tray
- 6—Extension tray
- 7—Original glass
- 8—Original cover pad
- 9—Scanner unit
- 10—USB memory port

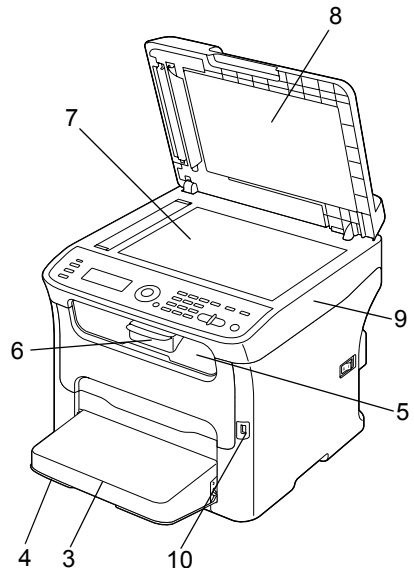
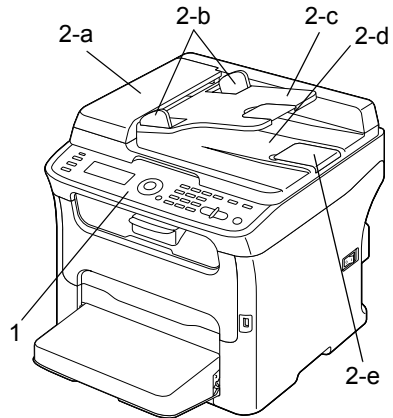

- 11—Fuser unit
- 12—Fuser separator levers
- 13—Fuser cover lever
- 14—Imaging cartridge
- 15—Toner cartridge
- 16—Front cover

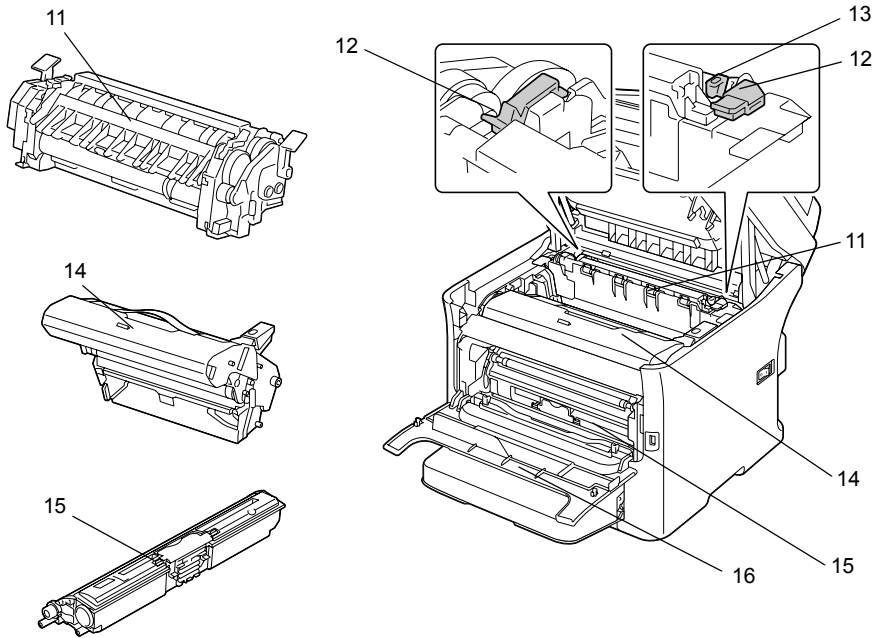

## Rear View

- 1—Power switch
- 2—Power connection
- 3—TEL (telephone) jack
- 4—LINE (telephone line) jack
- 5—USB port
- 6—10Base-T/100Base-TX (IEEE 802.3) Ethernet Interface port

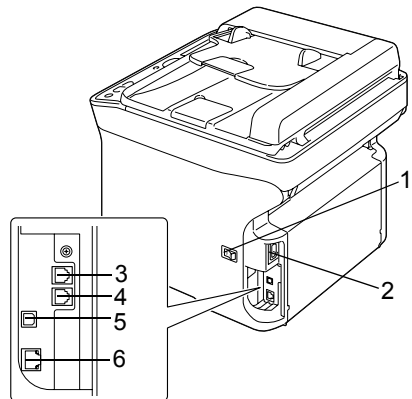

## Front View with Options

(when Tray 2 is installed)

1—Lower feeder unit (Tray 2)

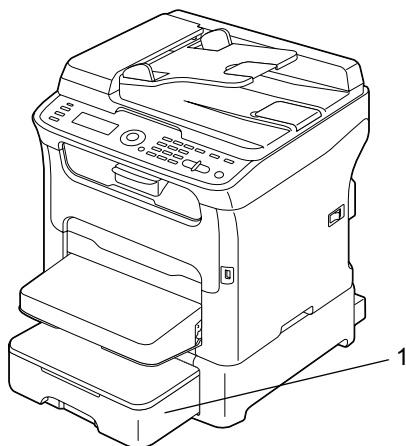

(when Tray 2 and duplex option are installed)

1—Duplex option

2—Lower feeder unit (Tray 2)

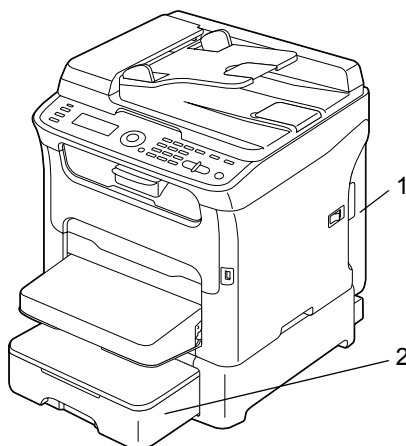

(when the attachment and duplex option are installed)

1—Duplex option

2—Attachment

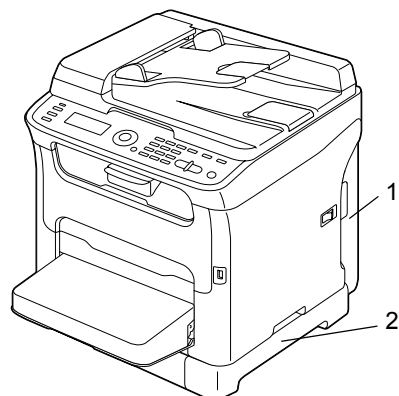

## Rear View with Options

(When Tray 2 is installed)

1—Lower feeder unit (Tray 2)

2—Locking pin

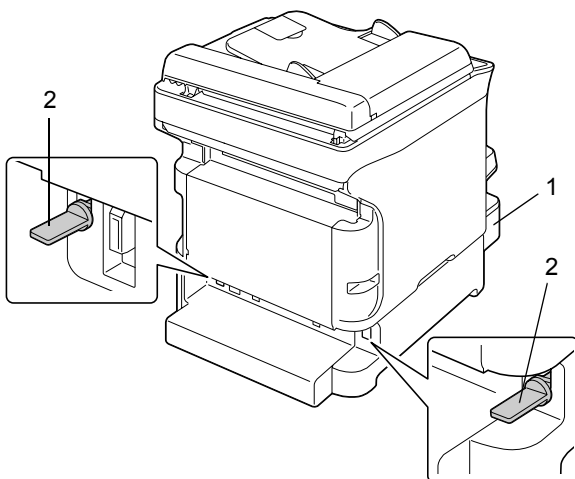

(when Tray 2 and duplex option are installed)

1—Duplex option

2—Lower feeder unit (Tray 2)

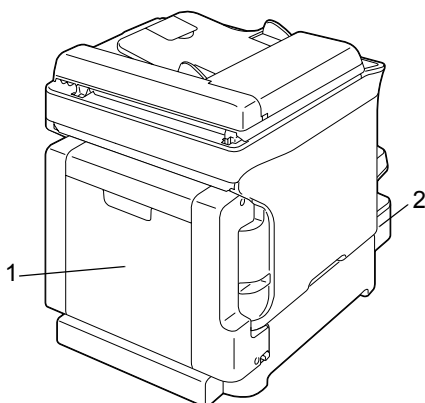

(when the attachment and duplex  
option are installed)

1—Duplex option

2—Attachment

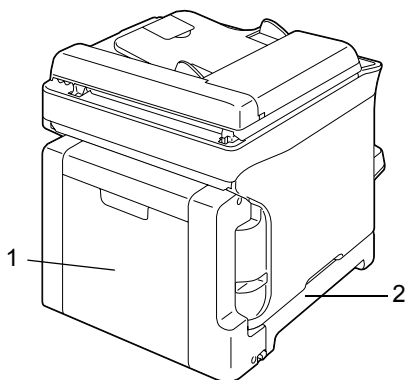

## Drivers CD/DVD

### Printer Drivers

Drivers	Use/Benefit
Windows Vista/XP/Server 2003/2000	These drivers give you access to all of the printer features. For details, refer to “Displaying Printer Driver Settings” on page 4-3.
Windows Vista/XP/Server 2003 for 64bit	
Macintosh OS X (10.2.8/10.3/10.4/10.5)	

### Scanner Drivers

Drivers	Use/Benefit
TWAIN Driver for Windows Vista/XP/Server 2003/2000	These drivers enable you to set scanning functions, such as the color setting and size adjustments.  For details, refer to “Windows TWAIN Driver Settings” on page 6-3.
TWAIN Driver for Macintosh OS X (10.2.8/10.3/10.4/10.5)	
WIA Driver for Windows Vista/XP	This driver enables you to set scanning functions, such as the color setting and size adjustments.  For details, refer to “Windows WIA Driver Settings” on page 6-5.
WIA Driver for Windows Vista/XP for 64 bit	

### PC Fax Drivers

Drivers	Use/Benefit
Windows Vista/XP/Server 2003/2000	These drivers enable you to specify fax settings, such as the paper settings for sending faxes and the settings for editing the address book. For details, refer to the Facsimile User’s Guide on the Documentation CD/DVD.
Windows Vista/XP/Server 2003 for 64 bit	



*For details on the installation of the drivers, refer to the Installation Guide.*



*For details of the Macintosh drivers, refer to the Reference Guide on the Documentation CD/DVD.*



*Windows TWAIN driver does not correspond to 64-bit applications though it corresponds to 32-bit applications on 64-bit OS.*



# Applications CD/DVD

## Applications

Applications	Use/Benefit
PaperPort SE	<p>This software is a document management software package that helps you scan, organize, access, share, and manage both your paper and digital documents on your personal computer.</p> <p>For details, refer to the PaperPort SE User's Guide from the Help menu.</p>
Local Setup Utility (LSU)	<p>This software enables destinations (scanning and faxing) in the favorite list, in speed dialing and in group dialing to be created or edited from the computer. In addition, the status of this machine can be checked.</p> <p>For details, refer to the Reference Guide on the Documentation CD/DVD.</p>
LinkMagic	<p>This software enables scanned documents to be saved in a file, processed, mail attached, and printed out.</p> <p>For details, refer to the Reference Guide on the Documentation CD/DVD.</p>
PageScope Net Care	<p>Printer management functions such as status monitoring and network settings can be accessed.</p> <p>For details, refer to the PageScope Net Care Quick Guide on the Applications CD/DVD.</p>
PageScope Network Setup	<p>Using the TCP/IP, basic network printer settings can be specified.</p> <p>For details, refer to the PageScope Network Setup User Manual on the Applications CD/DVD.</p>

# Documentation CD/DVD

## Documentation

<b>Documentation</b>	<b>Use/Benefit</b>
Installation Guide	This manual provides installation details that must be performed in order to use this machine, such as setting up the machine and installing the drivers.
Printer/Copier/Scanner User's Guide (this manual)	This manual provides details on general daily operations, such as using the drivers and control panel and replacing consumables.
Facsimile User's Guide	This manual provides details on general fax operations, such as sending and receiving faxes and using the control panel.
Reference Guide	This manual provides details on installing the Macintosh drivers and on specifying settings for the network, Local Setup Utility (LSU), LinkMagic and the printer management utility.
Quick Guide	The Quick Guide provides simple procedures for copy, fax and scanning operations and for replacing consumables.
Service & Support Guide	The Need Assistance sheet provides information on product support and servicing.
Readme	This guide provides details on operating conditions and precautions. Be sure to read this information before using the machine.

# System Requirements

- Personal computer

For Windows

- Pentium II: 400MHz or higher (Pentium 3: 500MHz or higher is recommended)

For Macintosh

- PowerPC G3 or later (G4 or later is recommended)
- Intel processor

- Operating System

- Microsoft Windows Vista Home Basic/Home Premium/Ultimate/Business/Enterprise, Windows Vista Home Basic/Home Premium/Ultimate/Business/Enterprise x64 Edition, Windows XP Home Edition/Professional (Service Pack 2 or later), Windows XP Professional x64 Edition, Windows Server 2003, Windows Server 2003 x64 Edition, Windows 2000 (Service Pack 4 or later)
- Mac OS X (10.2.8 or later; We recommend installing the latest patch)

- Free hard disk space

256 MB or more

- RAM

128 MB or more

- CD/DVD drive

- I/O interface

- 10Base-T/100Base-TX (IEEE 802.3) Ethernet interface port
- USB Revision 2.0 and USB Revision 1.1 compliant port



*The Ethernet cable and USB cable are not included with the machine.*



*For details of the Macintosh drivers, refer to the Reference Guide on the Documentation CD/DVD.*

***Control Panel  
and Configuration  
Menu***

**2**



# About the Control Panel

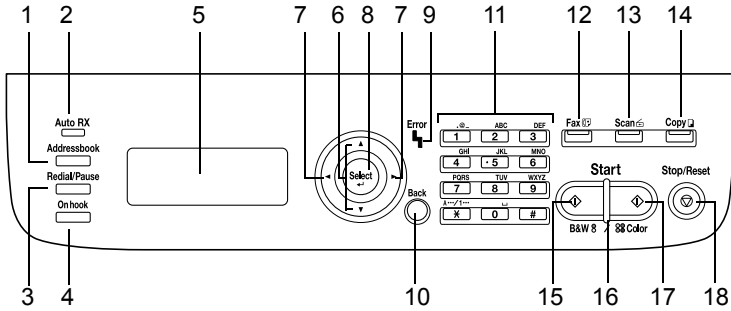

## Control Panel Indicators and Keys

No.	Name	Function
1	<b>Addressbook</b> key	Displays the information registered in the favorite list, speed dial destinations and group dial destinations.  For details, refer to the Facsimile User's Guide on the Documentation CD/DVD.
2	<b>Auto RX</b> indicator	Lights up when the automatic receiving function is selected.  For details, refer to the Facsimile User's Guide on the Documentation CD/DVD.
3	<b>Redial/Pause</b> key	Recalls the last number dialed. Inserts a pause when a number is dialed.  For details, refer to the Facsimile User's Guide on the Documentation CD/DVD.
4	<b>Onhook</b> key	Sends and receives transmissions with the receiver on the hook.  For details, refer to the Facsimile User's Guide on the Documentation CD/DVD.
5	<b>Message window</b>	Displays settings, menus, and messages.

No.	Name	Function
6	▲/▼ keys	Moves up and down through menus, options, or choices.
7	◀/▶ keys	Moves left and right through menus, options, or choices.
8	<b>Select</b> key	Press to select the setting that is currently displayed.
9	<b>Error</b> indicator	Indicates an error condition.
10	<b>Back</b> key	<p>Clears the specified number of copies and entered text.</p> <p>Press to return to the previous screen.</p> <p>Press to cancel the setting that is currently displayed.</p>
11	<b>Keypad</b>	Enters desired number of copies. Enters fax numbers, E-mail addresses, and names of recipients.
12	<b>Fax</b> key/LED	<p>Enters Fax mode.</p> <p>Lights up in green to indicate that the machine is in Fax mode.</p> <p>For details, refer to the Facsimile User's Guide on the Documentation CD/DVD.</p>
13	<b>Scan</b> key/LED	<p>Enters Scan mode. (Scan to E-mail, Scan to FTP, Scan to a shared folder on a computer, Scan to PC, or Scan to USB Memory)</p> <p>Lights up in green to indicate that the machine is in Scan mode.</p> <p>For details on the Scanner functions, refer to chapter 6, "Using the Scanner"</p>
14	<b>Copy</b> key/LED	<p>Enters Copy mode.</p> <p>Lights up in green to indicate that the machine is in Copy mode.</p> <p>For details on the Copy functions, refer to chapter 5, "Using the Copier".</p>
15	<b>Start</b> (B&W) key	Starts monochrome copying, scanning or faxing.
16	<b>Start</b> indicator	<p>Lights up in blue when copying and fax transmissions are possible.</p> <p>Lights up in orange when copying and fax transmissions are not possible, for example, during warm-up or if an error has occurred.</p>

No.	Name	Function
17	<b>Start</b> (Color) key	Starts color copying, scanning or faxing.
18	<b>Stop/Reset</b> key	Returns the settings to their defaults and stops functions.

# Display Indications

## Main Screen (Copy Mode)

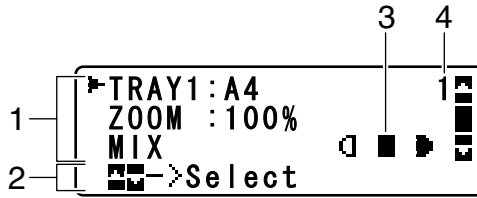

No.	Indication	Description
1	Copy settings	Allows the current settings to be checked and the various settings to be changed. For details, refer to "Copy settings" on page 2-6.
2	Status	Depending on the situation, the machine status or an error message may appear.
3	Copy density	Indicates the copy density.  AUTO appears when DENSITY is set to AUTO and the TEXT copy mode is selected.
4	Number of copies	Indicates the number of copies.



■ Copy settings

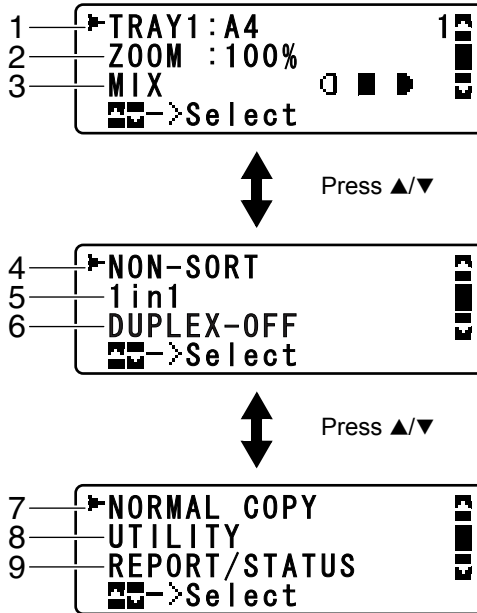

No.	Indication	Description
1	Media tray	Indicates the media tray that is selected. For details on selecting the media tray, refer to “Selecting the Media Tray” on page 5-5.
2	Zoom ratio	Indicates the zoom ratio that is specified. For details on specifying the zoom ratio, refer to “Specifying the Zoom Ratio” on page 5-4.
3	Copy quality	Indicates the copy quality that is selected. For details on selecting the copy quality, refer to “Specifying the Copy Quality Setting” on page 5-3.
4	Collated (Sort) copying	Indicates whether or not collated (Sort) copying is selected. For details on selecting collated (Sort) copying, refer to “Setting Collated (Sort) Copying” on page 5-13.
5	2in1 copying	Indicates whether or not 2in1 copying is selected. For details on selecting 2in1 copying, refer to “Setting 2in1 Copying” on page 5-6.

No.	Indication	Description
6	Double-sided copying	This appears only when the duplex option has been installed. Indicates whether or not double-sided copying is selected. If double-sided copying is selected, the specified binding position is indicated. For details on selecting double-sided copying, refer to “Setting Duplex (Double-Sided) Copying” on page 5-11.
7	Copy function	Indicates the copy function that is set. For details on setting a copy function, refer to “Setting a Copy Function” on page 5-7.
8	UTILITY	Select this menu item to change the various machine settings. For details, refer to “UTILITY Menu” on page 2-20.
9	REPORT/STATUS	Select this menu item to view the total number of pages printed by this machine and the results of fax transmissions/receptions as well as to print the reports. For details, refer to “REPORT/STATUS Menu” on page 2-17.

## Main Screen (Scan Mode)

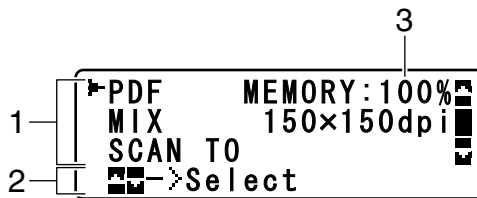



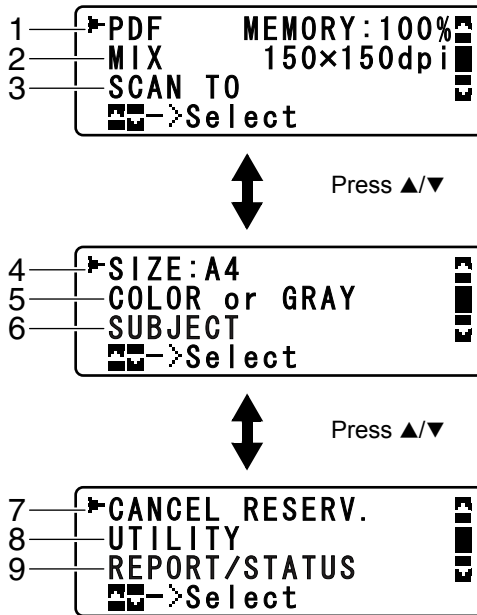

No.	Indication	Description
1	Scan settings	Allows the current settings to be checked and the various settings to be changed. For details, refer to “Scan settings” on page 2-8.
2	Status	Depending on the situation, the machine status or an error message may appear.
3	Available memory	Indicates the percentage of memory available for scanning operations.

■ Scan settings



No.	Indication	Description
1	Data format	Indicates the data format that is selected. For details on selecting the data format, refer to “Selecting the Data Format” on page 6-26.
2	Scan quality	Indicates the scan quality that is selected. For details on selecting the scan quality, refer to “Selecting the Scan Quality Setting” on page 6-27.
3	Scan data destination	Indicates the specified destination for the scan data. For details on specifying the destination of the data, refer to “Specifying the Data Location” on page 6-10 and “Specifying the Destination Address (Scan to E-mail/FTP/SMB)” on page 6-12.   <i>If no destination has been specified, SCAN TO appears.</i>
4	Scan size	Indicates the scan size that is selected. For details on selecting the scan size, refer to “Setting the Scan Size” on page 6-28.

No.	Indication	Description
5	Scan color	Indicates the scan color that is selected. For details on selecting the scan color, refer to “Setting the Scan Color” on page 6-28.
6	SUBJECT	<p>Select this menu item to specify the subject. For details on specifying the subject, refer to “Specifying the Subject” on page 6-28.</p> <p> <i>This menu item does not appear if an FTP address or SMB address was specified as the destination.</i></p>
7	CANCEL RESERV.	<p>Select this menu item to display the list of jobs queued for transmission and to delete a job. For details, refer to “Deleting a Queued Transmission Job” on page 6-29.</p> <p> <i>This menu item does not appear if an e-mail address, FTP address or SMB address was specified as the destination.</i></p>
8	UTILITY	<p>Select this menu item to change the various machine settings. For details, refer to “UTILITY Menu” on page 2-20.</p> <p> <i>This menu item does not appear if an e-mail address, FTP address or SMB address was specified as the destination.</i></p>
9	REPORT/STA- TUS	<p>Select this menu item to view the total number of pages printed by this machine and the results of fax transmissions/receptions as well as to print the reports. For details, refer to “REPORT/STATUS Menu” on page 2-17.</p> <p> <i>This menu item does not appear if an e-mail address, FTP address or SMB address was specified as the destination.</i></p>

## Main Screen (Fax Mode)

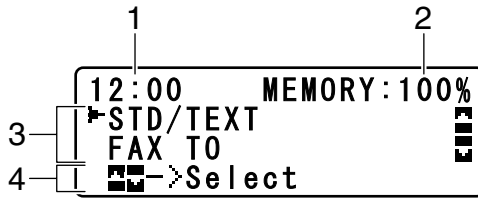

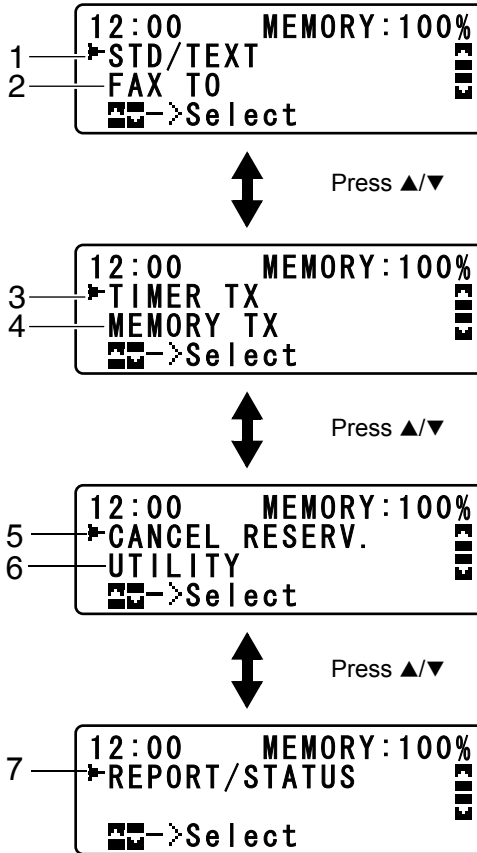

No.	Indication	Description
1	Time	Indicates the current time configured in ADMIN . MANAGEMENT/USER SETTING/DATE&TIME in the UTILITY menu.
2	Available mem- ory	Indicates the percentage of memory available for fax operations.
3	Fax settings	Allows the current settings to be checked and the various settings to be changed. For details, refer to "Fax settings" on page 2-11.
4	Status	Depending on the situation, the machine status or an error message may appear.

■ Fax settings



No.	Indication	Description
1	Fax quality	Indicates the fax quality that is selected. For details on selecting the fax quality, refer to the Facsimile User's Guide on the Documentation CD/DVD.
2	Fax destination	Indicates the specified fax destination. For details on specifying the destination, refer to the Facsimile User's Guide on the Documentation CD/DVD.  If no destination has been specified, FAX TO appears.

No.	Indication	Description
3	TIMER TX	Select this menu item to specify the time when the fax is to be sent. For details, refer to the Facsimile User's Guide on the Documentation CD/DVD.
4	Transmission mode	Indicates the fax transmission mode that is selected. For details on selecting the transmission mode, refer to the Facsimile User's Guide on the Documentation CD/DVD.
5	CANCEL RESERV.	<p>Select this menu item to display the list of jobs queued for transmission and to delete a job. For details, refer to "Deleting a Queued Transmission Job" on page 6-29.</p> <p> <i>This menu item does not appear if a destination has been specified.</i></p>
6	UTILITY	<p>Select this menu item to change the various machine settings. For details, refer to "UTILITY Menu" on page 2-20.</p> <p> <i>This menu item does not appear if a destination has been specified.</i></p>
7	REPORT/STA-TUS	<p>Select this menu item to view the total number of pages printed by this machine and the results of fax transmissions/receptions as well as to print the reports. For details, refer to "REPORT/STATUS Menu" on page 2-17.</p> <p> <i>This menu item does not appear if a destination has been specified.</i></p>

## Print Screen

When a print job is received, **PRINTER: Printing** appears in the status section of the main screen. To display the print screen (as shown below), press the **◀** key while **PRINTER: Printing** is displayed.

To cancel printing, press the **Stop/Reset** key when the print screen appears. Press the **Select** key to select **YES**.

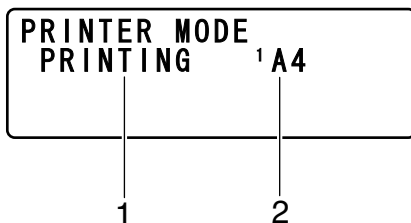

No.	Indication	Description
1	Status	Displays messages indicating operations such as printing.
2	Media tray/ media size	Indicates the media tray and media size that is selected.



*When a print job is received from the printer driver, the paper size specified with the printer driver has priority if it is different from the paper size specified from the control panel with **TRAY1 PAPER SETUP** in the **UTILITY** menu.*



# Checking the Machine Status and Settings

## PRINTER MODE Menu

With the main screen displayed, press the ◀ key to display the PRINTER MODE screen.

From this menu, a general estimate of the amount of toner remaining in the toner cartridges can be viewed, and the printer operation mode can be switched. The printer operation modes include one for replacing a toner cartridge (REPLACE MODE), one for replacing all toner cartridges (EJECT MODE), and one for cleaning the print head window (P/H CLEAN MODE). The PRINTER MODE menu is structured as shown below.



To return to the previous screen, press the **Back** key. To display the main screen, press the **Stop/Reset** key.

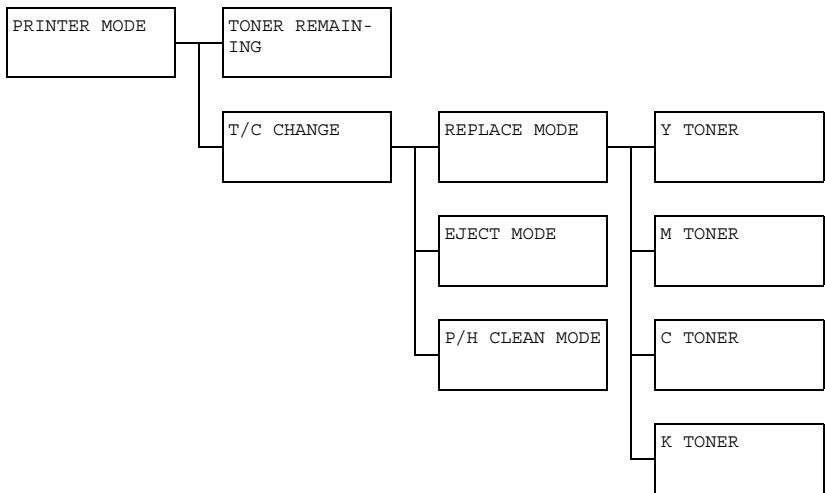



## TONER REMAINING

A general estimate of the amount of toner remaining in the toner cartridges can be viewed.



If the **Select** key is held down for at least 2 seconds while the screen described above is displayed, the configuration page will be printed.

## T/C CHANGE

REPLACE MODE	<p>Switches the machine to the REPLACE MODE. This mode is used when replacing a toner cartridge.</p> <p>For details on replacing a toner cartridge, refer to “Replacing a Toner Cartridge” on page 7-5.</p> <p> To return to normal operation mode from REPLACE MODE, press the <b>Stop/Reset</b> key.</p>
EJECT MODE	<p>Switches the machine to the EJECT MODE. This mode is used when replacing all toner cartridges at the same time.</p> <p>For details on replacing all toner cartridges, refer to “Replacing All Toner Cartridges at the Same Time” on page 7-10.</p> <p> To return to normal operation mode from EJECT MODE, press the <b>Stop/Reset</b> key.</p>

P/H CLEAN MODE	<p>Switches the machine to the P/H CLEAN MODE.</p> <p>P/H CLEAN MODE is a mode that allows the user to clean the print head window more easily. The print head window is not cleaned automatically.</p> <p>For details on cleaning the print head window, refer to “Clearing the Print Head Window” on page 8-16.</p> <p> <i>To return to normal operation mode from P/H CLEAN MODE, refer to “Clearing the Print Head Window” on page 8-16.</i></p>
----------------	---

## REPORT/STATUS Menu

To display the REPORT/STATUS screen, select REPORT / STATUS in the main screen, and then press the **Select** key. From this menu, the total number of pages printed by this machine and the results of fax transmissions/receptions can be viewed. In addition, the reports can be printed. The REPORT/STATUS menu is structured as shown below.



To return to the previous screen, press the **Back** key. To display the main screen, press the **Stop/Reset** key.

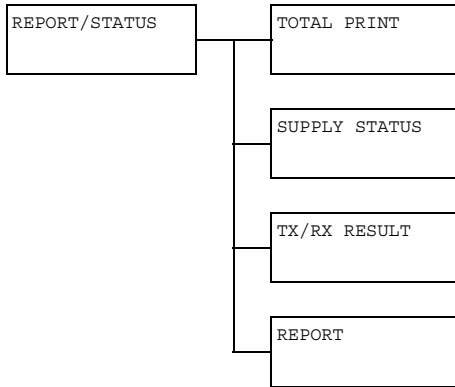

### TOTAL PRINT

The total number of pages for each of the following can be checked.

TOTAL PRINT	This counter shows the total number of pages printed.
MONO COPY	This counter shows the total number of pages copied in black-and-white.
COLOR COPY	This counter shows the total number of pages copied in color.
MONO PRINT	This counter shows the total number of pages printed in black-and-white.
COLOR PRINT	This counter shows the total number of pages printed in color.
FAX PRINT	This counter shows the total number of pages that were faxed.
TOTAL SCAN	This counter shows the total number of document pages that were scanned.

## SUPPLY STATUS

The remaining amount of toner in the toner cartridges and the remaining service life of the imaging cartridges can be displayed as a percentage.

C TONER	Displays the remaining amount of toner in the cyan (C) toner cartridge as a percentage.
M TONER	Displays the remaining amount of toner in the magenta (M) toner cartridge as a percentage.
Y TONER	Displays the remaining amount of toner in the yellow (Y) toner cartridge as a percentage.
K TONER	Displays the remaining amount of toner in the black (K) toner cartridge as a percentage.
I/C	Displays the remaining service life of the imaging cartridge as a percentage.

## TX/RX RESULT

For details, refer to the Facsimile User's Guide on the Documentation CD/DVD.

## REPORT

The machine settings, lists and reports related to fax can be printed.

These reports can only be printed from Tray 1.

TX RESULT REPORT	Prints the results of fax transmissions. For details, refer to the Facsimile User's Guide on the Documentation CD/DVD.
RX RESULT REPORT	Prints the results of fax receptions. For details, refer to the Facsimile User's Guide on the Documentation CD/DVD.
ACTIVITY REPORT	Prints the results of fax transmissions and receptions. For details, refer to the Facsimile User's Guide on the Documentation CD/DVD.
MEMORY DATA LIST	Prints the information for queued fax transmissions. For details, refer to the Facsimile User's Guide on the Documentation CD/DVD.
MEMORY IMAGE PRINT	Prints the information and a reduced first page of queued fax transmissions. For details, refer to the Facsimile User's Guide on the Documentation CD/DVD.

FAVORITE LIST	Prints a list of the destinations registered in the favorite list. For details, refer to the Facsimile User's Guide on the Documentation CD/DVD.
SPEED DIAL LIST	Prints a list of the destinations programmed for speed dialing. For details, refer to the Facsimile User's Guide on the Documentation CD/DVD.
GROUP DIAL LIST	Prints a list of the one-touch dialing groups. For details, refer to the Facsimile User's Guide on the Documentation CD/DVD.
UTILITY MAP	Prints the UTILITY menu and its settings.
CONFIGURATION PAGE	Prints a estimate of the percentage of toner remaining and the settings, information and status of this machine.
DEMO PAGE	Prints a demo page.

# Configuration Menu Overview

To display the settings menu for this machine, select **UTILITY** in the main screen, and then press the **Select** key. From the **UTILITY** menu, settings for the various machine functions can be changed.

## UTILITY Menu

From this menu, various machine settings can be changed. The **UTILITY** menu is structured as shown below.



To return to the previous screen in the **UTILITY** menu, press the **Back** key. (If the **Back** key is pressed while settings are being specified, those settings are not saved.)



The **ADMIN. MANAGEMENT** menu is accessible only by the administrator. To display the settings for this menu, select **ADMIN. MANAGEMENT**, use the keypad to type in the 6-digit administrator access code (default: **000000**), and then press the **Select** key.

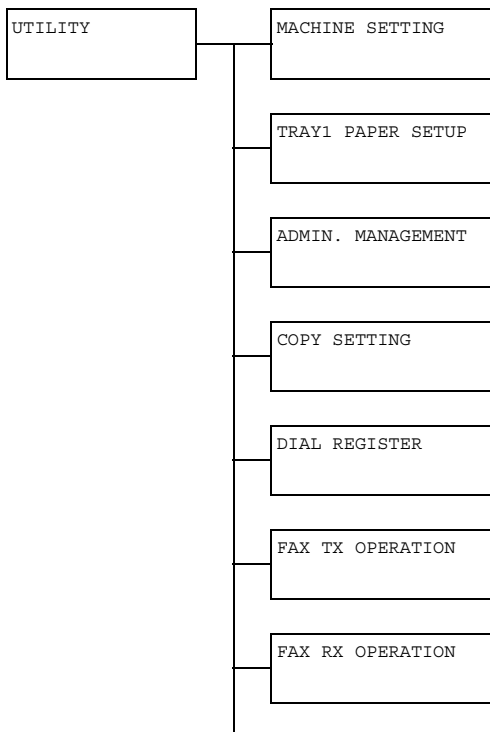

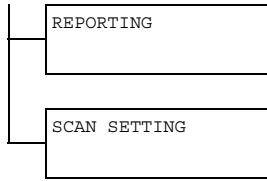



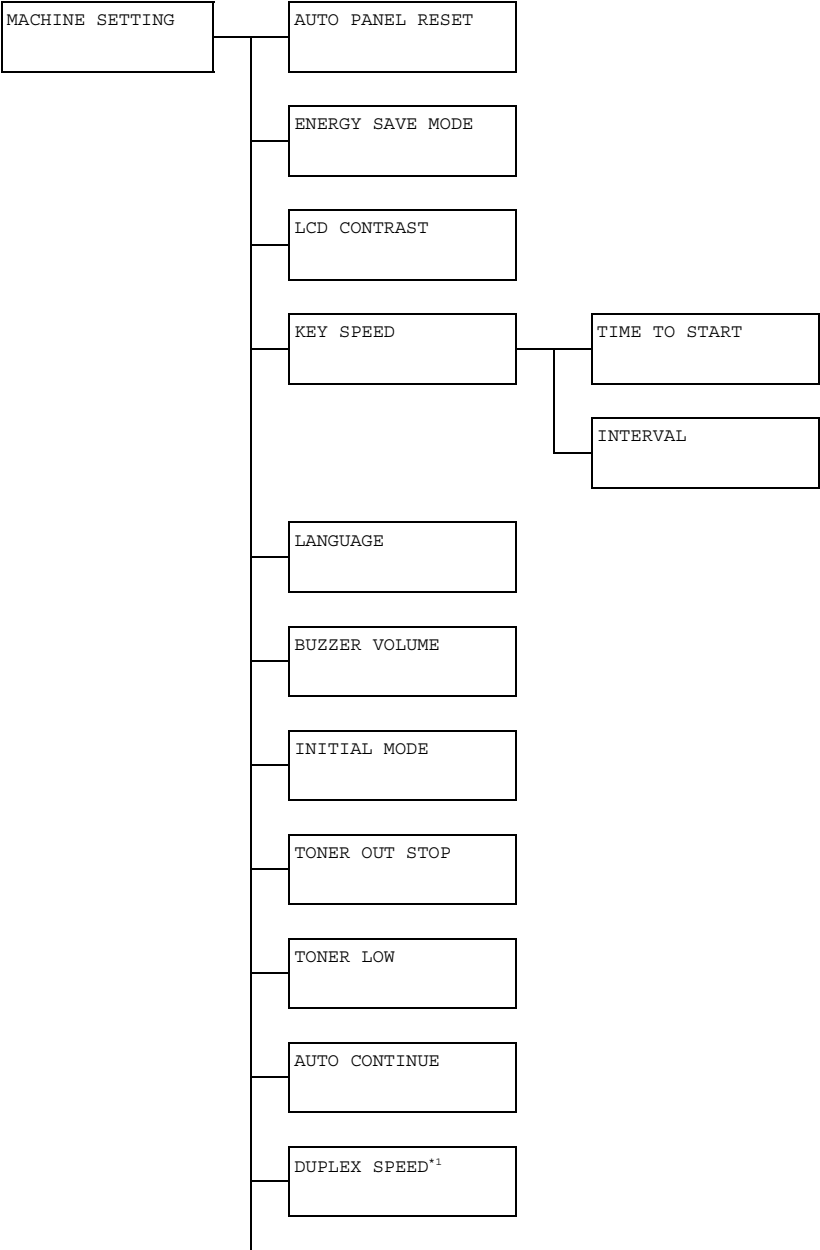

# MACHINE SETTING Menu



 \*1 This appears only when the duplex option has been installed.

 Manufacturer's default settings appear in bold.

AUTO PANEL RESET		Setting	OFF / 30sec / <b>1min</b> / 2min / 3min / 4min / 5min
		Specify the length of time until all settings that have not been programmed, such as the number of copies, are cleared and return to their default settings when no operation is performed.  To set the machine to perform the auto panel reset operation, select from 30sec, 1min, 2min, 3min, 4min or 5min for the length of time until the auto panel reset operation is performed.	
ENERGY SAVE MODE		Setting	5 min / 15 min / <b>30 min</b> / 60 min
		Enters Energy Save mode in order to conserve energy when no operation is performed. Specify the length of time in minutes until the machine enters Energy Save mode.	
LCD CONTRAST		Setting	(LIGHT)  (DARK)
		Specify the brightness of the message window.	
KEY SPEED	TIME TO START	Setting	0.1sec / 0.3sec / 0.5sec / <b>1.0sec</b> / 1.5sec / 2.0sec / 2.5sec / 3.0sec
		Specify the length of time until the cursor begins to move continuously when a key is held down.	
	INTERVAL	Setting	<b>0.1sec</b> / 0.3sec / 0.5sec / 1.0sec / 1.5sec / 2.0sec / 2.5sec / 3.0sec
		Specify the length of time until the cursor continuously moves between settings or characters.	

LANGUAGE	Setting	<b>ENGLISH</b> / FRENCH / GERMAN / ITALIAN / SPANISH / PORTUGUESE / RUSSIAN / CZECH / SLOVAK / HUNGARIAN / POLISH / JAPANESE
	Select the language of the menus and messages that appear in the message window.	
BUZZER VOLUME	Setting	OFF / <b>LOW</b> / HIGH
	Select the volume of the sound produced when a key is pressed and of the alarm that is sounded when an error occurs.	
INITIAL MODE	Setting	<b>COPY</b> / FAX
	Specify the default mode when the machine is turned on or when all settings in the control panel return to their default settings.	
TONER OUT STOP	Setting	<b>ON</b> / ON (FAX) / OFF
	<p>Select whether or not printing, copying and faxing stop when the toner has run out.</p> <p>If <b>ON</b> is selected, printing, copying and faxing stop when the toner runs out.</p> <p>If <b>ON (FAX)</b> is selected, only faxing stops when the toner has run out. Printing and copying continues.</p> <p>If <b>OFF</b> is selected, printing, copying and faxing continues even if toner has run out.</p>	
TONER LOW	Setting	<b>ON</b> / OFF
	Select whether or not a warning message appears when the toner is nearly empty.	
AUTO CONTINUE	Setting	ON / <b>OFF</b>
	Select whether or not printing continues when a size error occurs during printing.	

DUPLEX SPEED	Setting	<b>AUTOMATIC</b> / SPEED / QUALITY
	<p>Select the print speed for double-sided printing.</p> <p>If <b>AUTOMATIC</b> is selected, the print speed is automatically selected.</p> <p>If <b>SPEED</b> is selected, the print speed has priority; however, the print quality may decrease.</p> <p>If <b>QUALITY</b> is selected, the print quality has priority; therefore, the print speed will decrease while the print quality may increase.</p>	
CALIBRATION	Setting	ON / <b>OFF</b>
	<p>Select whether or not to perform image stabilization. If <b>ON</b> is selected, image stabilization is started.</p>	

## TRAY1 PAPER SETUP Menu

TRAY1 PAPER SETUP
-------------------



*Manufacturer's default settings appear in bold.*

Media type	<b>PLAIN PAPER</b> / LETTERHEAD / THICK1 / THICK2 / LABELS / ENVELOPE / POSTCARD	
Paper size	The available paper sizes differ depending on the setting selected as the media type.	
	Setting selected as the media type	Available paper sizes
	PLAIN PAPER	<b>A4</b> / A5 / B5 / LEGAL / <b>LETTER</b> / G LETTER / STATEMENT / EXECUTIVE / FOLIO / OFICIO / G LEGAL / CUSTOM (PLAIN)
	THICK1, THICK2	<b>A4</b> / A5 / B5 / <b>LETTER</b> / G LETTER / STATEMENT / EXECUTIVE / CUSTOM (THICK)
	LETTERHEAD, LABELS	<b>A4</b> / A5 / B5 / <b>LETTER</b> / G LETTER / STATEMENT / EXECUTIVE
	ENVELOPE	<b>C6</b> / DL
	POSTCARD	The screen for selecting the paper size does not appear, and the following paper size is automatically specified.  100 × 148 mm [3.9 × 5.8 inch]

Select the type and size of the media loaded into Tray 1. If CUS - TOM (PLAIN) or CUSTOM (THICK) is selected as the paper size, specify settings for LENGTH and WIDTH separately.

The setting range for LENGTH is 195 to 356 mm for PLAIN PAPER, and 184 to 297 mm for THICK1 and THICK2.

The default setting is 297 mm.

The Setting range for WIDTH is 92 to 216 mm.

The default setting is 210 mm.

When a media type is selected, a screen appears, showing the available media sizes. The available media sizes differ depending on the selected media type.

The default paper size for a setting other than ENVELOPE or POSTCARD is **LETTER** for 120 V models, and **A4** for 220 V models.



*When printing from the printer driver, the printer driver settings have priority over the settings specified in the TRAY1 PAPER SETUP menu. Check that Tray 1 is loaded with media of the type and size specified in the printer driver.*



*The setting for CUSTOM is displayed in metric (mm) even if ADMIN. MANAGEMENT/USER SETTING/PRESET ZOOM is set to INCH.*

## ADMIN. MANAGEMENT Menu



The ADMIN. MANAGEMENT menu is accessible only by the administrator. To display the settings for this menu, select ADMIN. MANAGEMENT, use the keypad to type in the 6-digit administrator access code (default: 000000), and then press the **Select** key.

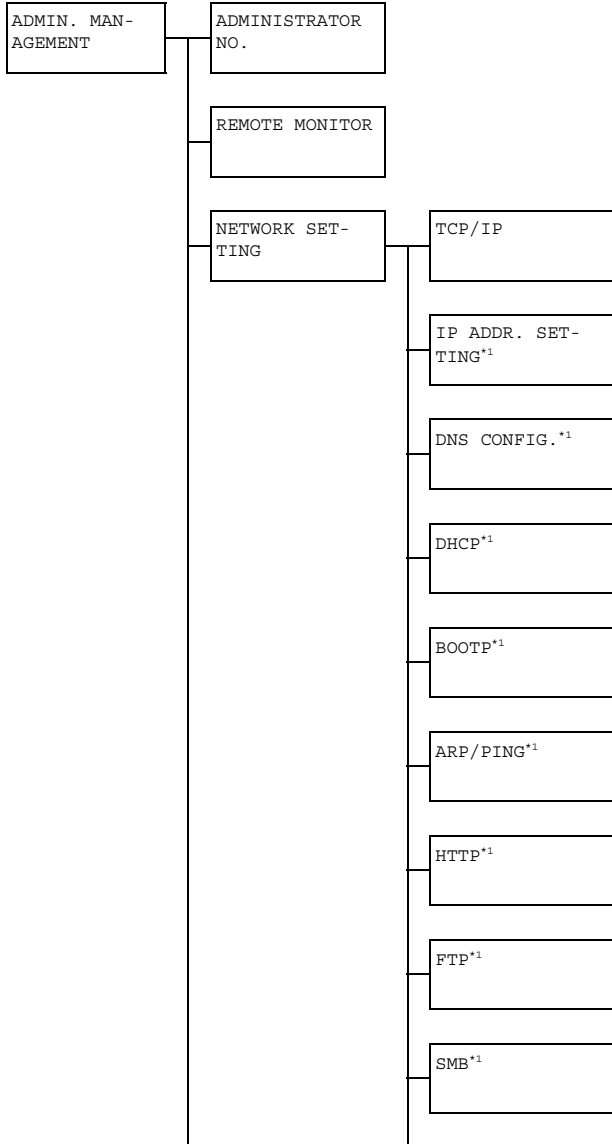

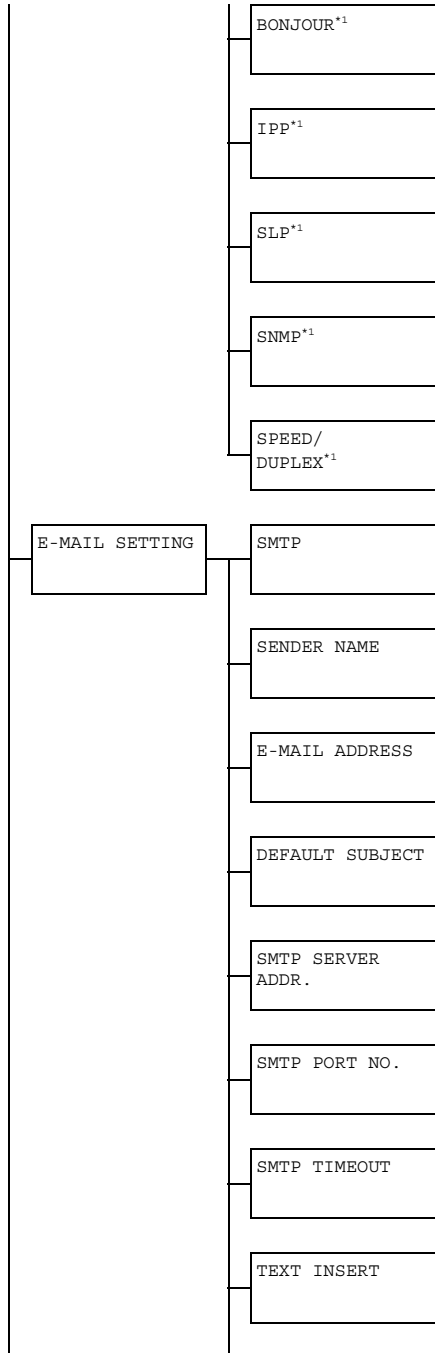



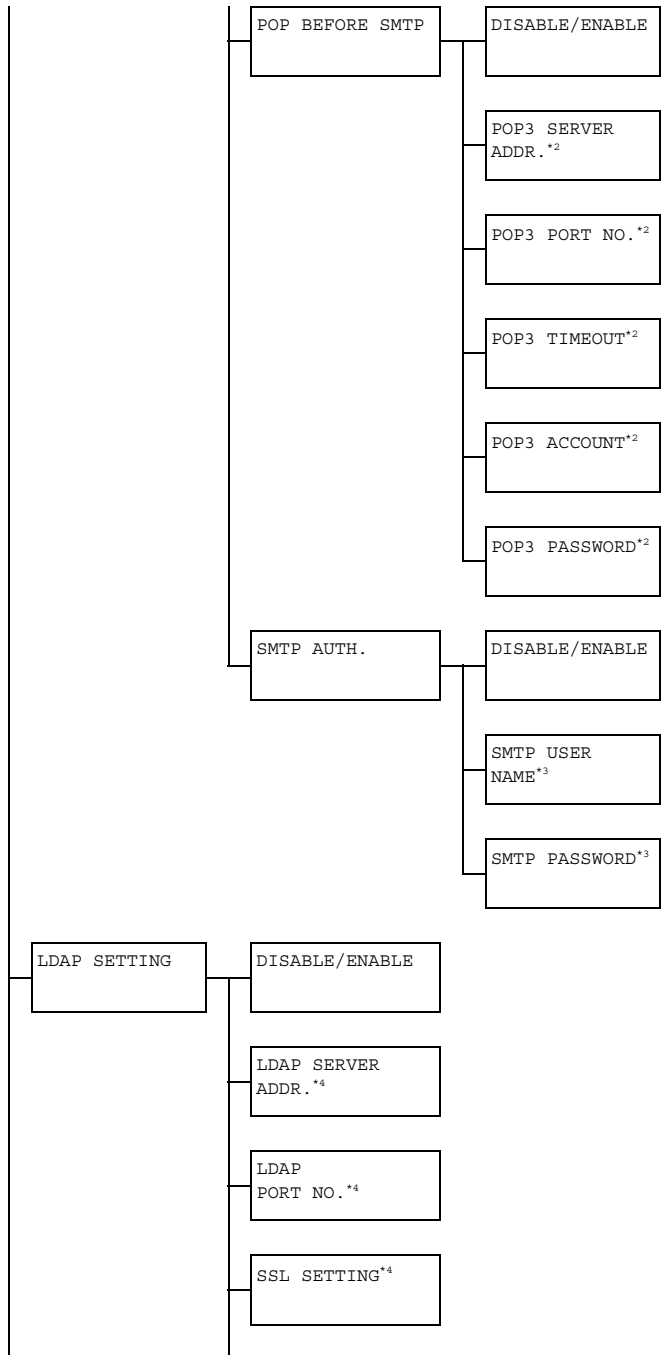

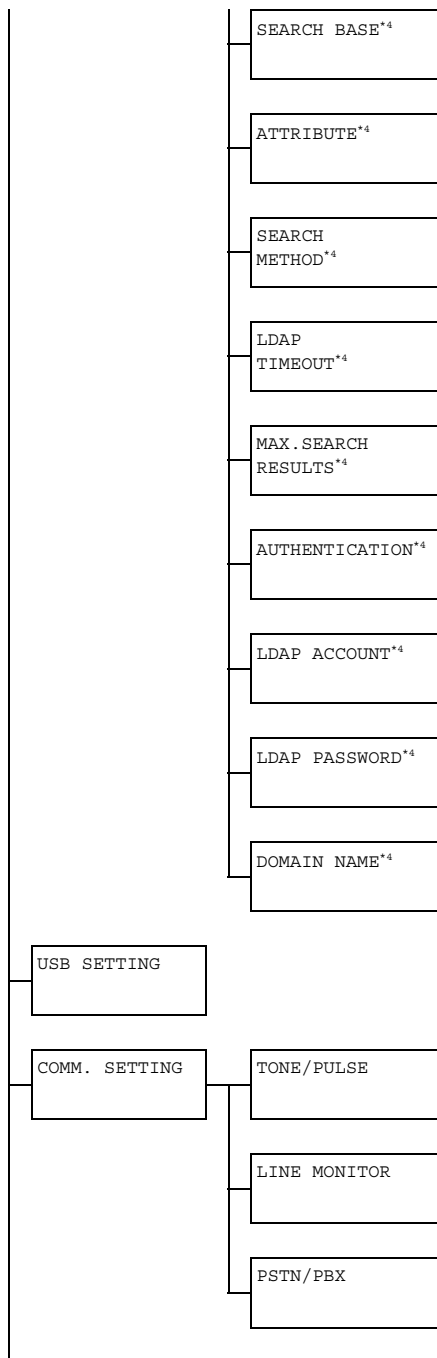

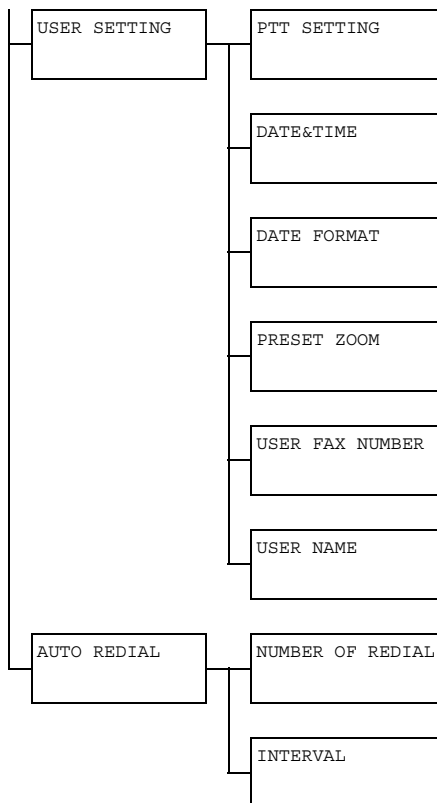

<sup>\*1</sup> This menu item appears when ADMIN. MANAGEMENT/NETWORK SETTING/TCP/IP is set to ENABLE.

<sup>\*2</sup> This menu item appears when ADMIN. MANAGEMENT/E-MAIL SETTING/POP BEFORE SMTP/DISABLE/ENABLE is set to ENABLE.

<sup>\*3</sup> This menu item appears when ADMIN. MANAGEMENT/E-MAIL SETTING/SMTP AUTH./DISABLE/ENABLE is set to ENABLE.

<sup>\*4</sup> This menu item appears when ADMIN. MANAGEMENT/LDAP SETTING/DISABLE/ENABLE is set to ENABLE.



Manufacturer's default settings appear in bold.

ADMINISTRATOR NO .		Specify the new administrator access code.	
REMOTE MONITOR		Setting	<b>OFF</b> / ON
		<p>Select whether or not setting remote monitor.</p> <p>If ON is selected, technical support can access the menu mode.</p> <p>If OFF is selected, technical support cannot access the menu mode.</p> <p> <i>This setting is for technical support uses. Change the setting only when it is necessary.</i></p>	
NETWORK SETTING	TCP/IP	Setting	DISABLE / <b>ENABLE</b>
	Select the setting for connecting to this machine through a network.		
	IP ADDR. SETTING	Setting	<b>AUTO</b> / SPECIFY
Set the IP address of this machine on the network.			
If AUTO is selected, the IP address will be assigned automatically.			
If SPECIFY is selected, manually specify settings for IP ADDRESS, SUBNET MASK and GATEWAY.			

DNS CONFIG.	Setting	<b>DISABLE</b> / ENABLE
	Set whether or not the DNS server setting is to be specified.  If <b>ENABLE</b> is selected, specify DNS server addresses (up to three addresses).	
DHCP	Setting	DISABLE / <b>ENABLE</b>
	If there is a DHCP server on the network, specify whether the IP address and other network information is automatically assigned by the DHCP server.	
BOOTP	Setting	<b>DISABLE</b> / ENABLE
	If there is a BOOTP server on the network, specify whether the IP address and other network information is automatically assigned by the BOOTP server.	
ARP/PING	Setting	<b>DISABLE</b> / ENABLE
	Select whether or not the ARP/PING command is used when the IP address is assigned.	
HTTP	Setting	DISABLE / <b>ENABLE</b>
	Select whether or not to enable HTTP.	
FTP	Setting	DISABLE / <b>ENABLE</b>
	Select whether or not to enable FTP.	
SMB	Setting	DISABLE / <b>ENABLE</b>
	Select whether or not to enable SMB.	
BONJOUR	Setting	DISABLE / <b>ENABLE</b>
	Select whether or not to enable Bonjour.	
IPP	Setting	DISABLE / <b>ENABLE</b>
	Select whether or not to enable IPP.   <i>If HTTP is set to DISABLE, IPP cannot be set.</i>	
SLP	Setting	DISABLE / <b>ENABLE</b>
	Select whether or not to enable SLP.	

	SNMP	Setting	DISABLE / <b>ENABLE</b>
		Select whether or not to enable SNMP.	
	SPEED/DUPLEX	Setting	<b>AUTO</b> / 10BASE-T FULL / 10BASE-T HALF / 100BASE-TX FULL / 100BASE-TX HALF
		Specifies the transmission speed for the network and the transmission method for bi-directional transmission.	
E-MAIL SETTING	SMTP	Setting	DISABLE / <b>ENABLE</b>
		Select whether to enable or disable e-mail transmission operations for this machine.	
	SENDER NAME	Specify the name of the E-mail sender (up to 20 characters) used for network scanning.  The default setting is " <b>magicolor_1690MF</b> ".	
	E-MAIL ADDRESS	Specify the E-mail address (up to 64 characters) of the E-mail sender used for network scanning.  The default setting is blank.	
	DEFAULT SUBJECT	Specify the subject (up to 20 characters) of the E-mail message used for network scanning.  The default setting is " <b>From mc1690MF</b> ".	
	SMTP SERVER ADDR.	Specify the IP address or host name (up to 64 characters) for the SMTP server. The default setting is " <b>0.0.0.0</b> ".	
	SMTP PORT NO.	Setting	1 to 65535 (Default: <b>25</b> )
Specify the port number communicating with the SMTP server.			

SMTP TIMEOUT		Setting	30 to 300 sec (Default: 60 sec)
		Select the amount of time (in seconds) until the connection with the SMTP server times out.	
TEXT INSERT		Setting	OFF / ON
		Select whether or not the specified text is inserted into the E-mail message.	
POP BEFORE SMTP	DIS-ABLE/ENABLE	Setting	DISABLE / ENABLE
		Select whether or not to enable POP Before SMTP.  If ENABLE is selected, specify the time (between 0 and 60 seconds). The default setting is <b>5sec</b> .	
	POP3 SERVER ADDR.	Specify the host name or IP address for the POP3 server used for authentication with POP Before SMTP.  The default setting is "0.0.0.0".	
	POP3 PORT NO.	Setting	1 to 65535 (Default: 110)
		Specify the port number used for communicating with the POP3 server.	
	POP3 TIME-OUT	Setting	30 to 300 sec (Default: 30 sec)
		Select the amount of time (in seconds) until the connection with the POP3 server times out.	
	POP3 ACCOUNT	Specify the user name (up to 63 characters) used for authentication with POP3 server.  The default setting is blank.	
POP3 PASS-WORD	Specify the password (up to 15 characters) used for authentication with POP3 server.  The default setting is blank.		

	SMTP AUTH.	DIS-ABLE/ENABLE	Setting	<b>DISABLE</b> / <b>ENABLE</b>
			Select whether or not to enable SMTP authentication.	
		SMTP USER-NAME	Specify the user name (up to 63 characters) used for SMTP authentication. The default setting is blank.	
		SMTP PASS-WORD	Specify the password (up to 15 characters) used for SMTP authentication. The default setting is blank.	
LDAP SETTING	DISABLE/ENABLE		Setting	<b>DISABLE</b> / <b>ENABLE</b>
			Select whether or not to enable the LDAP function.	
	LDAP SERVER ADDR.		Specify the address (up to 64 characters) of the LDAP server. The default setting is " <b>0.0.0.0</b> ".	
	LDAP PORT NO.	Setting	1 to 65535 (Default: <b>389</b> )	
		Specify the port number of the LDAP server.		
	SSL SETTING		Setting	<b>DISABLE</b> / <b>ENABLE</b>
			Select whether or not to enable SSL.	
	SEARCH BASE		Specify the search starting point (up to 64 characters) in a hierarchical structure arranged on the LDAP server. The default setting is blank.	
	ATTRIBUTE		The conditions for searches can be specified as a name or e-mail address (up to 32 characters). The default setting is " <b>cn</b> ".	
	SEARCH METHOD	Setting	<b>BEGIN</b> / <b>CONTAIN</b> / <b>END</b>	
The specified characters can be searched for at the beginning, within or at the end.				
LDAP TIMEOUT	Setting	5 to 300 sec (Default: <b>60 sec</b> )		
	Specify the maximum wait time during a search.			



	MAX . SEARCH RESULTS	Setting	5 to 100 (Default: 100)
		Specify the maximum number of destinations displayed after a search.	
	AUTHENTICATION	Setting	<b>ANONYMOUS</b> / SIMPLE / DIGEST-MD5 / GSS-SPNEGO
		Select the authentication method used for logging on to the LDAP server.	
	LDAP ACCOUNT	Specify the account (up to 64 characters) used to connect to the LDAP server.  The default setting is blank.	
	LDAP PASSWORD	Specify the password (up to 32 characters) used to connect to the LDAP server.  The default setting is blank.	
DOMAIN NAME	Specify the domain name (up to 64 characters) used to connect to the LDAP server.  The default setting is blank.		
USB SETTING		Setting	<b>Windows</b> / Mac
		Select the operating system of the PC to which this machine is connected with a USB cable.	
COMM . SETTING	TONE/PULSE	Setting	<b>TONE</b> / PULSE
		<p>Select the dialing system. If this parameter is not correctly set to the type of dialing system used, faxes cannot be sent and received.</p> <p>Select the correct setting after checking which type of dialing system is used by your telephone line.</p> <p> <i>If PTT SETTING in the USER SETTING menu is set to U . S . A, CANADA or NEW ZEALAND, the settings cannot be changed.</i></p>	

	LINE MONITOR	Setting	OFF / <b>LOW</b> / HIGH
		Select the volume of the monitoring sound of the transmission signal.	
	PSTN/PBX	Setting	<b>PSTN</b> / PBX
		<p>Select whether the connected telephone wiring is a public switched telephone network (PSTN) or a private branch exchange (PBX).</p> <p>For a PBX system, the prefix number (outside line access number or extension number) can be specified.</p>	
USER SETTING	PTT SETTING	Setting	ARGENTINA / AUSTRALIA / AUSTRIA / BELGIUM / BRAZIL / CANADA / CHINA / CZECH / DENMARK / EUROPE / FINLAND / FRANCE / GERMANY / GREECE / HONG KONG / HUNGARY / IRELAND / ISRAEL / ITALY / JAPAN / KOREA / MALAYSIA / MEXICO / THE NETHERLANDS / NEW ZEALAND / NORWAY / PHILIPPINES / POLAND / PORTUGAL / RUSSIA / SAUDI ARABIA / SINGAPORE / SLOVAKIA / SOUTH AFRICA / SPAIN / SWEDEN / SWITZERLAND / TAIWAN / TURKEY / <b>U.S.A</b> / UNITED KINGDOM / VIETNAM
		Select the country where this machine is installed.	

	DATE&TIME	Setting	TIME: 00:00-23:59 (Default: 00 : 00)  DATE: '00/01/01-'99/12/31  ZONE: GMT+12:00-GMT-12:00 (in 30-minute intervals) (Default: GMT+00 : 00)
		Use the keypad to specify the current date, time and time zone.	
	DATE FORMAT	Setting	MM/DD/YY, DD/MM/YY, YY/MM/DD
		Select the display format for reports and lists.	
	PRESET ZOOM	Setting	INCH / METRIC
		Select the measurement units for the preset zoom ratios.  The default setting is <b>INCH</b> for USA and Canada, and <b>METRIC</b> for other countries.	
USER FAX NUMBER	Enter your fax number. A maximum of 20 characters (consisting of numbers, spaces, + and -) can be entered. The specified number is printed in the header of outgoing faxes. The default setting is blank.		
USER NAME	Enter your name. A maximum of 32 characters can be entered. The specified name is printed in the header of outgoing faxes. The default setting is blank.		
AUTO REDIAL	NUMBER OF REDIAL	Setting	1 to 10 (Default: depends on PTT SETTING)
		Specify the number of times a redial is attempted if there is no answer, for example, when the line is busy.	

	INTERVAL	Setting	2 to 99 min (Default: depends on PTT SETTING)
		Specify the interval between redial attempts.	

## COPY SETTING Menu

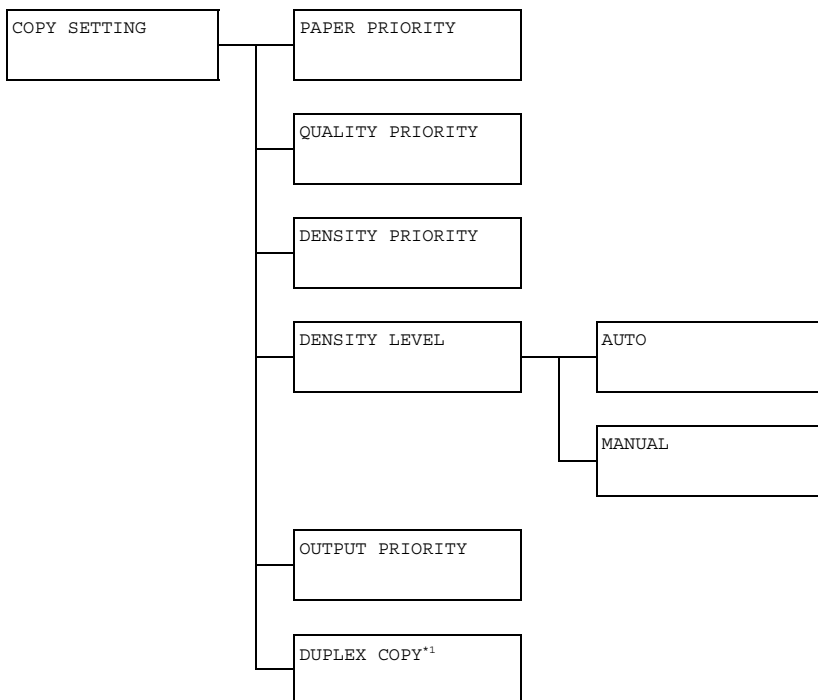

 \*1 This appears only when the duplex option has been installed.

 Manufacturer's default settings appear in bold.

PAPER PRIORITY	Setting	<b>TRAY1</b> / TRAY2
	Specify the paper tray that is normally used.  If an optional lower feeder unit is not installed, this setting is not available.	
QUALITY PRIORITY	Setting	<b>MIX</b> , TEXT , PHOTO , FINE/MIX , FINE/TEXT , FINE/PHOTO
	Select the type of document being copied.	
DENSITY PRIORITY	Setting	<b>AUTO</b> / MANUAL
	Select the density that is normally used.	

DEN- SITY LEVEL	AUTO	Setting	(LIGHT) ◀■■■■▶ (DARK)
		Adjust the density of the background color.	
	MANUAL	Setting	(LIGHT) ◀■■■■■■■■▶ (DARK)
		Specify the default copy density.	
OUTPUT PRIOR- ITY	Setting	<b>NON - SORT</b> / SORT	
	Select whether or not to sort copies by sets.		
DUPLEX COPY	Setting	<b>OFF</b> / LONG EDGE / SHORT EDGE	
	<p>Select the default setting for duplex (double-sided) copying.</p> <p>If <b>OFF</b> is selected, duplex (double-sided) copying is not performed as a default.</p> <p>If <b>LONG EDGE</b> is selected, duplex (double-sided) copying is performed as a default, and the pages are fed out with the binding along the long side.</p> <p>If <b>SHORT EDGE</b> is selected, duplex (double-sided) copying is performed as a default, and the pages are fed out with the binding along the short side.</p>		

## DIAL REGISTER Menu

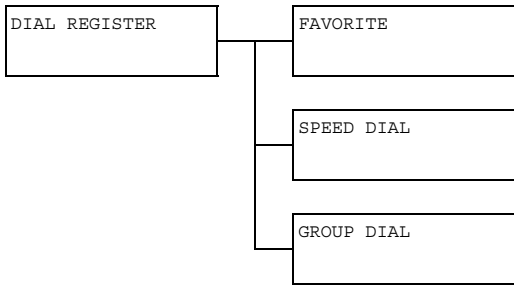

FAVORITE	<p>Register frequently used fax numbers and e-mail addresses in the favorite list. Instead of being entered manually, fax numbers and e-mail addresses can simply be recalled to ensure that destination information is registered correctly.</p> <p>A maximum of 20 destinations can be registered in the favorite list.</p>
SPEED DIAL	<p>Register frequently used fax numbers and e-mail addresses as speed dial destinations. Instead of being entered manually, fax numbers and e-mail addresses can simply be recalled to ensure that destination information is registered correctly.</p> <p>A maximum of 250 speed dial destinations can be registered.</p> <p>For details, refer to and “Registering Speed Dial Destinations (Direct Input)” on page 6-21 and “Registering Speed Dial Destinations (LDAP Search)” on page 6-22.</p>
GROUP DIAL	<p>Register frequently used broadcast destinations as a group dial destination. Multiple destinations can be recalled simply by selecting a registered group.</p> <p>A maximum of 50 destinations can be registered with one group dial destination.</p> <p>A maximum of 9 group dial destinations can be registered.</p> <p>For details, refer to “Registering Group Dial Destinations” on page 6-24.</p>

## FAX TX OPERATION Menu

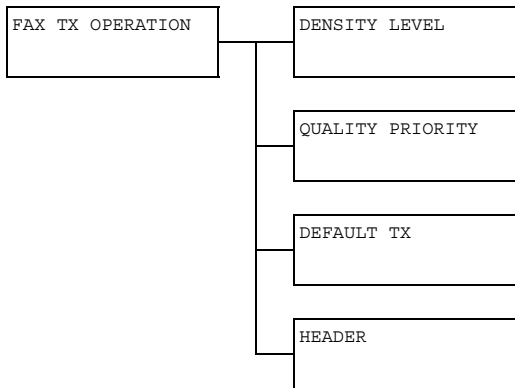

*Manufacturer's default settings appear in bold.*

DENSITY LEVEL	Setting	(LIGHT) <input type="checkbox"/> <input type="checkbox"/> <input type="checkbox"/> <input type="checkbox"/> (DARK)
	Specify the density for scanning a document.	
QUALITY PRI - ORITY	Setting	<b>STD/TEXT</b> , FINE/TEXT, S-FINE/ TEXT, STD/PHOTO, FINE/PHOTO, S-FINE/PHOTO
	Select the default scanning resolution (fax document quality).	
	STD/TEXT: Select this setting for documents containing handwriting or for computer printouts.	
	FINE/TEXT: Select this setting for documents containing small print.	
	S-FINE/TEXT: Select this setting for documents containing small print, such as newspapers, and documents containing detailed illustrations.	
	STD/PHOTO: Select this setting for photo documents containing regular photos.	
FINE/PHOTO: Select this setting for photo documents containing fine images.		
S-FINE/PHOTO: Select this setting for photo documents containing finer images.		



DEFAULT TX	Setting	<b>MEMORY TX / DIRECT TX</b>
HEADER	Setting	OFF / ON
	<p>Select the desired method for sending documents.</p> <p><b>MEMORY TX:</b> With this method, the fax transmission starts after the entire document is scanned and stored in the memory. The total number of pages is automatically printed with the page number in the header. However, the memory may become full if there are many pages in the document or if the data is large due to the fine image quality (resolution).</p> <p><b>DIRECT TX:</b> With this method, the transmission is performed in real time in the transmission sequence of the destinations. If there are many pages in the document, the fax can be sent with this method without the memory becoming full.</p>	
	<p>Select whether or not to print transmission source information (date/time of transmission, sender's name, sender's fax number, session number and page number) for the machine in the transmitted document.</p> <p> <i>If PTT SETTING in the USER SETTING menu is set to U. S. A, CANADA, or KOREA, this setting cannot be changed.</i></p>	

## FAX RX OPERATION Menu

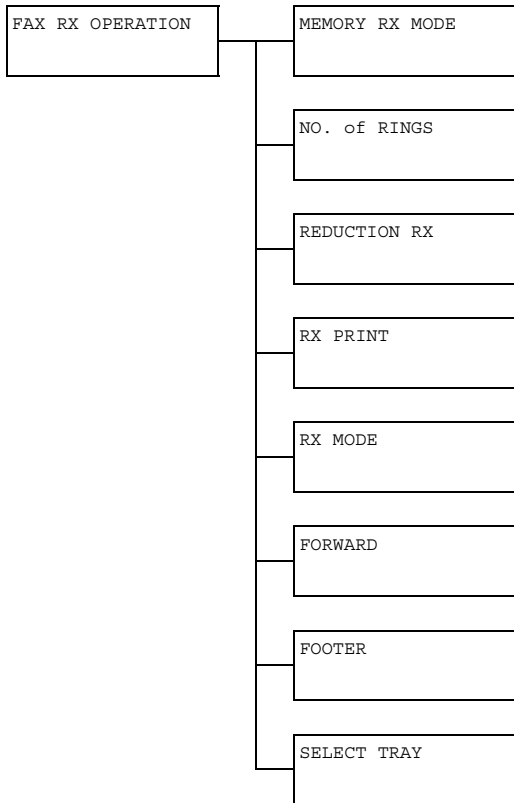

*Manufacturer's default settings appear in bold.*

MEMORY RX MODE	Setting	<b>OFF</b> / ON
		<p>Select whether to allow (ON) memory reception or not (OFF). Select ON not to print when receiving confidential faxes or when no one is around, for example, at night. The received documents can be stored in memory and printed at a specified time or when memory reception is turned off (this function is set to OFF).</p> <p>A password can be set to specify the starting time or ending time of memory reception, or to cancel the function. The set starting time and ending time are valid every day until memory reception is turned off.</p>

No. of RINGS	Setting	1 to 16 (Default: depends on PTT SETTING)
	<p>Enter the number of rings (between 1 and 16) until the machine automatically begins receiving the fax when an external telephone is connected.</p> <p> <i>If PTT SETTING in the USER SETTING menu is set to NEW ZEALAND, this setting range changes to 7 to 10.</i></p>	
REDUCTION RX	Setting	OFF / ON / CUT
	<p>Select whether documents longer than the current paper size are printed reduced, split, or discarded.</p> <p>OFF: The document is printed at full size and split onto multiple pages.</p> <p>ON: The document is printed at a reduced size.</p> <p>CUT: The document is printed, but any part that does not fit within the page is erased.</p>	
RX PRINT	Setting	MEMORY RX / PRINT RX
	<p>Select whether the fax is printed only after all document pages have been received or printing begins as soon as the first page of the document is received.</p> <p>MEMORY RX: Printing begins after all pages have been received.</p> <p>PRINT RX: Printing begins after the first page has been received.</p>	
RX MODE	Setting	AUTO RX / MANUAL RX
	<p>Select whether the reception mode is set to automatic reception or manual reception.</p> <p>AUTO RX: Automatically begins receiving the fax after the set number of rings.</p> <p>MANUAL RX: Does not automatically receive the fax. Reception begins after making a connection by picking up the telephone receiver or pressing the <b>Onhook</b> key, then pressing the <b>Start</b> key.</p>	

FORWARD	Setting	<b>OFF / ON / ON (PRINT)</b>
	<p>Select whether or not to forward received fax documents.</p> <p>OFF: Select this setting to not forward the document.</p> <p>ON: Select this setting to forward the received fax document to the specified fax number or e-mail address.</p> <p>ON (PRINT) : Select this setting to forward the received fax document to the specified fax number or e-mail address at the same time that the machine prints it.</p>	
FOOTER	Setting	<b>OFF / ON</b>
	<p>Select whether or not the reception information (date received, number of pages, etc.) is printed at the bottom of each received document.</p>	
SELECT TRAY	Setting	<b>TRAY1 / TRAY2</b>
	<p>Select which paper tray can be used to supply paper when printing received documents or transmission reports.</p> <p> <i>If an optional lower feeder unit is not installed, this setting is not available.</i></p>	

## REPORTING Menu

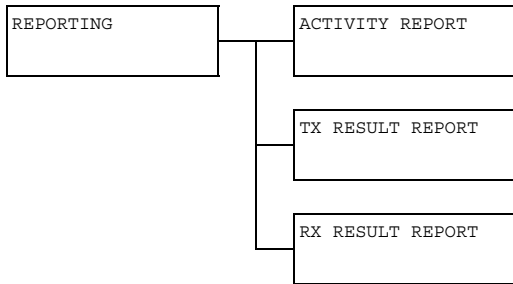

*Manufacturer's default settings appear in bold.*



ACTIVITY REPORT	Setting	OFF / <b>ON</b>
	After every 60 transmissions/receptions, a report can be printed to show the results of the transmissions/receptions. Select whether the report is printed automatically when the 60th transmission/reception is reached.	
TX RESULT REPORT	Setting	ON / <b>ON (ERROR)</b> / OFF
	<p>Select whether the report showing the result of a transmission is printed automatically after the transmission is finished.</p> <p>ON: Prints the report after each transmission.</p> <p>ON (ERROR) : Prints the report after a transmission only if an error occurred.</p> <p>OFF: Does not print the report after each transmission, even if an error has occurred.</p> <p>The transmission result report is normally printed after a broadcast transmission.</p>	

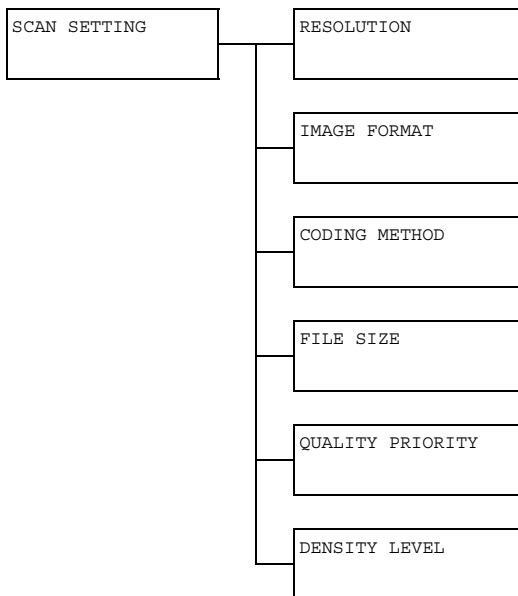

RX RESULT REPORT	Setting	ON / <b>ON (ERROR)</b> / OFF
	<p>Select whether the report showing the result of a reception is printed automatically after the reception is finished.</p> <p>ON: Prints the report after each reception.</p> <p>ON (ERROR) : Prints the report after a reception only if an error occurred.</p> <p>OFF: Does not print the report after each reception, even if an error has occurred.</p>	

## SCAN SETTING Menu



Manufacturer's default settings appear in bold.

RESOLUTION	Setting	<b>150×150dpi</b> / 300×300dpi
	Select the default scanning resolution for scan to E-mail operations.	
IMAGE FORMAT	Setting	TIFF / <b>PDF</b> / JPEG
	Select the default format for saving files with scan to E-mail operations.	
	<p> <i>PDF data can be opened in Adobe Acrobat Reader.</i></p> <p> <i>TIFF files of images that have been scanned with the Color or Gray setting cannot be opened with the Windows Picture and FAX Viewer, which is included with Windows XP as a standard component. These files can be opened with image-processing applications such as PhotoShop, Microsoft Office Document Imaging or ACDsee.</i></p>	

CODING METHOD	Setting	<b>MH / MR / MMR</b>
	<p>Select the default compression method for scan to E-mail operations.</p> <p>The compression ratio for these methods increases in the following order: MH &gt; MR &gt; MMR.</p> <p> <i>These settings are available only if BW Only was selected for the color setting during the e-mail transmission.</i></p>	
FILE SIZE	Setting	<b>NO SPLIT / SPLIT</b>
	<p>Select whether or not to limit the size for scan data sent as e-mail attachments.</p> <p>If SPLIT is selected, specify the maximum size between 1 and 10 Mb. If the data to be sent exceeds the maximum size allowed, the data is divided and sent as multiple attached files.</p> <p> <i>In order to receive multiple file attachments, an e-mail application compatible with divided transmissions is required.</i></p>	
QUALITY PRIORITY	Setting	<b>MIX / TEXT / PHOTO</b>
	<p>Select the scan data quality that is used as a default.</p>	
DENSITY LEVEL	Setting	(LIGHT)  (DARK)
	<p>Select the scan data density that is used as a default.</p>	





# *Media Handling* **3**



# Print Media

## Specifications

Media	Media Size		Tray*	Duplex	Copy	Print	FAX
	Inch	Millimeter					
A4	8.2 x 11.7	210.0 x 297.0	1/2	Yes	Yes	Yes	Yes
B5 (JIS)	7.2 x 10.1	182.0 x 257.0	1	No	Yes	Yes	No
A5	5.9 x 8.3	148.0 x 210.0	1	No	Yes	Yes	No
Legal	8.5 x 14.0	215.9 x 355.6	1	No	Yes (ADF)	Yes	Yes
Letter	8.5 x 11.0	215.9 x 279.4	1/2	Yes	Yes	Yes	Yes
Statement	5.5 x 8.5	139.7 x 215.9	1	No	Yes	Yes	No
Executive	7.25 x 10.5	184.2 x 266.7	1	No	Yes	Yes	No
Folio	8.25 x 13.0	210.0 x 330.0	1	No	Yes (ADF)	Yes	No
Letter Plus	8.5 x 12.69	215.9 x 322.3	1	No	No	Yes	No
UK Quarto	8.0 x 10.0	203.2 x 254.0	1	No	No	Yes	No
Foolscap	8.0 x 13.0	203.2 x 330.2	1	No	No	Yes	No
Government Legal	8.5 x 13.0	215.9 x 330.2	1	No	Yes (ADF)	Yes	No
B5 (ISO)	6.9 x 9.8	176.0 x 250.0	1	No	No	Yes	No
Envelope DL	8.7 x 4.3	220.0 x 110.0	1	No	Yes	Yes	No
Envelope C6	6.4 x 4.5	162.0 x 114.0	1	No	Yes	Yes	No
J-Postcard	3.9 x 5.8	100.0 x 148.0	1	No	Yes	Yes	No
Kai 16	7.3 x 10.2	185.0 x 260.0	1	No	No	Yes	No
Kai 32	5.1 x 7.3	130.0 x 185.0	1	No	No	Yes	No
Government Letter	8.0 x 10.5	203.2 x 266.7	1	No	Yes	Yes	No
16 K	7.7 x 10.6	195.0 x 270.0	1	No	No	Yes	No
Oficio Mexico	8.5 x 13.5	215.9 x 342.9	1	No	Yes (ADF)	Yes	Yes
Custom, Minimum**	3.6 x 7.7	92.0 x 195.0	1	No	Yes	Yes	No
Custom, Maximum**	8.5 x 14.0	216.0 x 356.0	1	No	Yes	Yes	No
<b>Notes:</b> *Tray 1 = Multipurpose Tray 2 = Plain paper only ** With thick stock The minimum size is 3.6 x 7.25 inch (92.0 x 184.0 mm). The maximum size is 8.5 x 11.7 inch (216.0 x 297.0 mm).							

## Types

Before purchasing a large quantity of special media, do a trial print with the same media and check the print quality.

Keep media on a flat, level surface in its original wrapper until it is time to load it. For a list of approved media, refer to <http://printer.konicaminolta.com>.

### Plain Paper (Recycled Paper)

<b>Capacity</b>	<b>Tray 1</b>	Up to 200 sheets, depending on the media weight
	<b>Tray 2</b>	Up to 500 sheets, depending on the media weight
<b>Orientation</b>	<b>Tray 1</b>	Face up
	<b>Tray 2</b>	Face up
<b>Driver Media Type</b>	Plain Paper (Recycled)	
<b>Weight</b>	60 to 90 g/m <sup>2</sup> (16 to 24 lb bond)	
<b>Duplexing</b>	Only Letter/A4 plain paper can be aut duplexed.	

#### Use plain paper that is

- Suitable for plain paper printers and copiers, such as standard or recycled office paper.

#### Note

---

---

**Do not use the media types listed below. These could cause poor print quality, media misfeeds, or damage to the machine.**

---

---

#### DO NOT use media that is

- Coated with a processed surface (such as carbon paper and colored paper that has been treated)
- Carbon backed
- Unapproved iron-on transfer media (such as heat-sensitive paper, heat-pressure paper, and heat-press transfer paper)
- Cold-water-transfer paper
- Pressure sensitive
- Designed specifically for inkjet printers (such as superfine paper, glossy film, and postcards)
- Already been printed on by another printer, copier, or fax machine

- Dusty
- Wet (or damp)
  -  *Keep media between 15% and 85% relative humidity. Toner does not adhere well to moist or wet media.*
- Layered
- Adhesive
- Folded, creased, curled, embossed, warped, or wrinkled
- Perforated, three-hole punched, or torn
- Too slick, too coarse, or too textured
- Different in texture (roughness) on the front and back
- Too thin or too thick
- Stuck together with static electricity
- Composed of foil or gilt; too luminous
- Heat sensitive or cannot withstand the fusing temperature (180°C [356°F])
- Irregularly shaped (not rectangular or not cut at right angles)
- Attached with glue, tape, paper clips, staples, ribbons, hooks, or buttons
- Acidic
- Any other media that is not approved

## Thick Stock

Paper thicker than 90 g/m<sup>2</sup> (24 lb bond) is referred to as thick stock. Test all thick stock to ensure acceptable performance and to ensure that the image does not shift.

You can print continuously with thick stock. However, this could affect the media feed, depending on the media quality and printing environment. If problems occur, stop the continuous printing and print one sheet at a time.

<b>Capacity</b>	<b>Tray 1</b>	Up to 50 sheets, depending on their thickness
	<b>Tray 2</b>	Not supported
<b>Orientation</b>	Face up	
<b>Driver Media Type</b>	Thick Stock 1 Thick Stock 2	

<b>Weight</b>	Thick Stock 1: 91 to 163 g/m <sup>2</sup> (25 to 43.5 lb bond) Thick Stock 2: 164 to 209 g/m <sup>2</sup> (43.6 to 55.6 lb bond)
<b>Duplexing</b>	Not supported

**DO NOT use thick stock that is**

- Mixed with any other media in the trays (as this will cause media misfeeding)

**Envelope**

Print on the front (address) side only. Some parts of the envelope consist of three layers of paper—the front, back, and flap. Anything printed in these layered regions may be lost or faded.

You can print continuously with envelope. However, this could affect the media feed, depending on the media quality and printing environment. If problems occur, stop the continuous printing and print one sheet at a time.

<b>Capacity</b>	<b>Tray 1</b>	Up to 10 sheets, depending on their thickness
	<b>Tray 2</b>	Not supported
<b>Orientation</b>	Face up	
<b>Driver Media Type</b>	Envelope	
<b>Duplexing</b>	Not supported	

**Use envelopes that are**

- Envelope DL or C6 size (Other envelope sizes are not supported.)
- Common office envelopes approved for laser printing with diagonal joints, sharp folds and edges, and ordinary gummed flaps



*Because the envelopes pass through heated rollers, the gummed area on the flaps may seal. Using envelopes with emulsion-based glue avoids this problem.*

- Approved for laser printing
- Dry

## **DO NOT use envelopes that have**

- Sticky flaps
- Tape seals, metal clasps, paper clips, fasteners, or peel-off strips for sealing
- Transparent windows
- Too rough of a surface
- Material that will melt, vaporize, offset, discolor, or emit dangerous fumes
- Been presealed

## **Label**

A sheet of labels consists of a face sheet (the printing surface), adhesive, and a carrier sheet:

- The face sheet must follow the plain paper specification.
- The face sheet surface must cover the entire carrier sheet, and no adhesive should come through on the surface.

You can print continuously with label sheets. However, this could affect the media feed, depending on the media quality and printing environment. If problems occur, stop the continuous printing and print one sheet at a time.

Try printing your data on a sheet of plain paper first to check placement. Check your application documentation for more information on printing labels.

<b>Capacity</b>	<b>Tray 1</b>	Up to 50 sheets, depending on their thickness
	<b>Tray 2</b>	Not supported
<b>Orientation</b>	Face up	
<b>Driver Media Type</b>	Labels	
<b>Duplexing</b>	Not supported	

## **Use label sheets that are**

- Recommended for laser printing

## **DO NOT use label sheets that**

- Have labels that easily peel off or have parts of the label already removed
- Have backing sheets that have peeled away or have exposed adhesive



*Labels may stick to the fuser, causing them to peel off and media misfeeds to occur.*

- Are precut or perforated

Do not use

OK to use

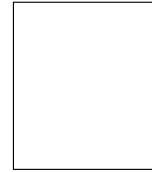
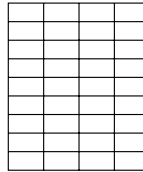
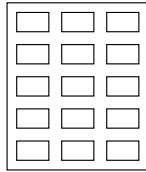
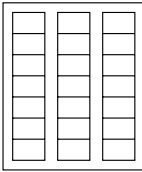

Shiny backed paper

Full-page labels (uncut)

## Letterhead

You can print continuously with letterhead. However, this could affect the media feed, depending on the media quality and printing environment. If problems occur, stop the continuous printing and print one sheet at a time.

Try printing your data on a sheet of plain paper first to check placement.

<b>Capacity</b>	<b>Tray 1</b>	Up to 50 sheets, depending on their size and thickness
	<b>Tray 2</b>	Not supported
<b>Orientation</b>	Face up	
<b>Driver Media Type</b>	Letterhead	
<b>Duplexing</b>	Not supported	

## Postcard

You can print continuously with postcard. However, this could affect the media feed, depending on the media quality and printing environment. If problems occur, stop the continuous printing and print one sheet at a time.

Try printing your data on a sheet of plain paper first to check placement.

<b>Capacity</b>	<b>Tray 1</b>	Up to 50 sheets, depending on their thickness
	<b>Tray 2</b>	Not supported
<b>Orientation</b>	Face up	



<b>Driver Media Type</b>	Postcard
<b>Duplexing</b>	Not supported

**Use postcards that are**

- Approved for laser printing

**DO NOT use postcards that are**

- Coated
- Designed for inkjet printers
- Precut or perforated
- Preprinted or multicolored



*If the postcard is warped, press on the warped area before putting it in the tray.*



- Folded or wrinkled

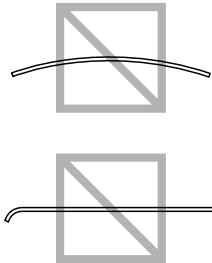

# Printable Area

The printable area on all media sizes is up to 4.0 mm (0.157") from the edges of the media.

Each media size has a specific printable area (the maximum area on which the machine can print clearly and without distortion).

This area is subject to both hardware limits (the physical media size and the margins required by the machine) and software constraints (the amount of memory available for the full-page frame buffer). The printable area for all media sizes is the page size minus 4.0 mm (0.157") from all edges of the media.

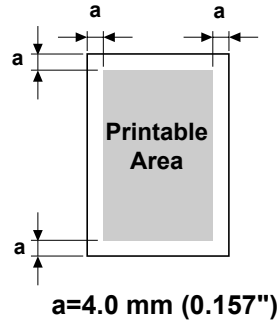

*When printing in color on legal-size media, the following limitations apply.*

- *The printable area is 339.6 (13.4") mm from the leading edge of the paper. (However, there is a non-printable area up to 4.0 mm (0.157") from the leading edge.)*
- *The bottom margin is 16.0 mm (0.63").*

## Envelopes

Envelopes can only be printed on their front sides (side where the recipient's address is written). In addition, printing on the front side in the area overlapping the back flap cannot be guaranteed. The location of this area differs depending on the envelope type.

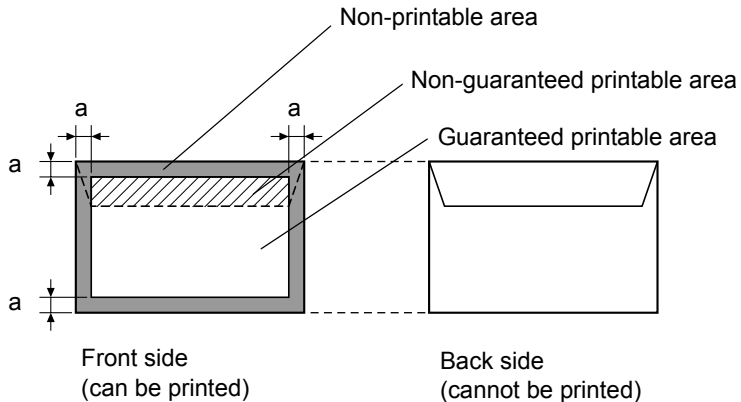

**a=4.0 mm (0.157")**



*The envelope print orientation is determined by your application.*



*With the Envelope DL size (long edge feeding), the nonprintable areas on the left and right sides are 6 mm.*

## Page Margins

Margins are set through your application. Some applications allow you to set custom page sizes and margins while others have only standard page sizes and margins from which to choose. If you choose a standard format, you may lose part of your image (due to printable area constraints). If you can custom-size your page in your application, use those sizes given for the printable area for optimum results.

# Loading Media

## How do I load media?

Take off the top and bottom sheets of a ream of paper. Holding a stack of approximately 200 sheets at a time, fan the stack to prevent static buildup before inserting it in a tray.

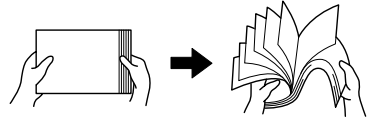

---

### Note

---

**Although this machine was designed for printing on a wide range of media types, it is not intended to print exclusively on a single media type except plain paper. Continuous printing on media other than plain paper (such as envelopes, labels, or thick stock) may adversely affect print quality or reduce engine life.**

---

When refilling media, first remove any media remaining in the tray. Stack it with the new media, even the edges, then reload it.

Do not mix media of different types and sizes, as this will cause media mis-feeds.

## Tray 1 (Multipurpose Tray)

For details on the types and sizes of media that can be printed from Tray 1, refer to "Print Media" on page 3-2.

### Loading Plain Paper

- 1 Remove the dust cover.

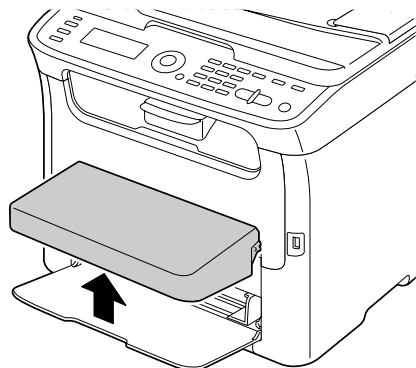

- 2 Slide the media guides to provide more space between them.

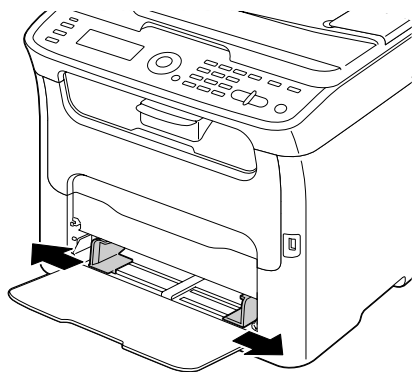

- 3 Load the paper face up in the tray.

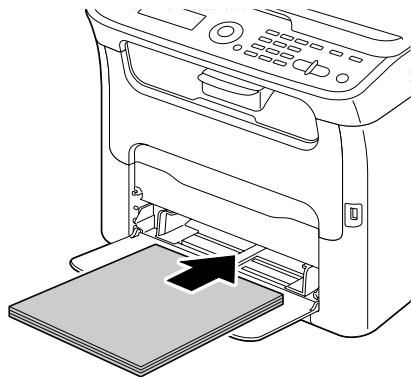

*Do not load paper above the ▼ mark. Up to 200 sheets (80 g/m<sup>2</sup> [21 lb]) of plain paper can be loaded into the tray at one time.*

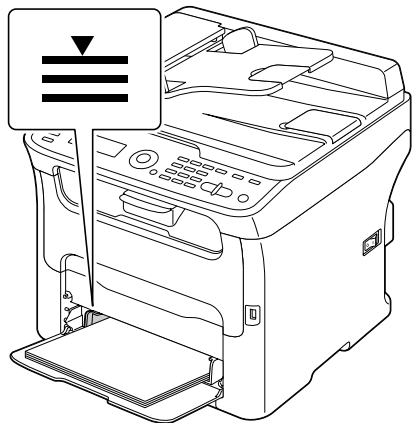

- 4** Slide the media guides against the edges of the paper.

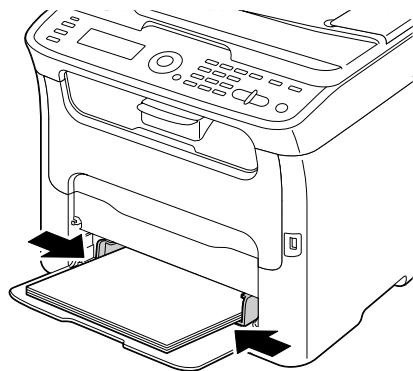

- 5** Install the dust cover.

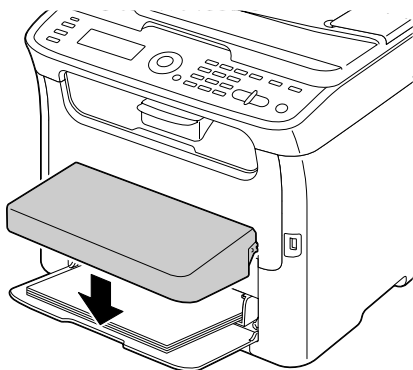

- 6** Select **TRAY1 PAPER SETUP** in the **UTILITY** menu, and then select the settings for the size and type of paper that is loaded. See also “Print Media” on page 3-2.

## Other Media

When loading media other than plain paper, set the media mode (Envelope, Label, Letterhead, Postcard, Thick Stock 1, or Thick Stock 2) in the driver for optimum print quality.

### Loading Envelopes

**1** Remove the dust cover.

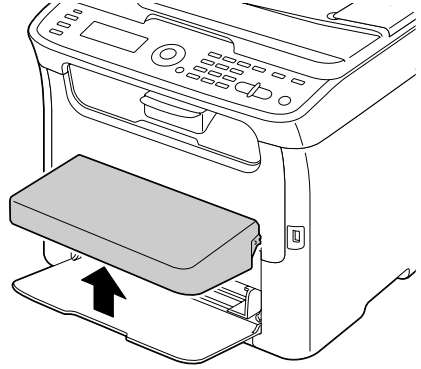

- 2** Remove any media in the tray.  
**3** Slide the media guides to provide more space between them.

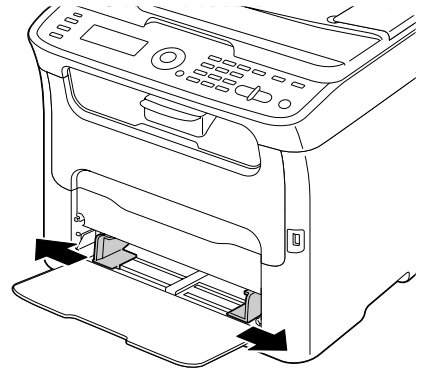

- 4** Load the envelopes flap side down in the tray.



*Before loading envelopes, press them down to make sure that all air is removed, and make sure that the folds of the flaps are firmly pressed, otherwise the envelopes may become wrinkled or a media misfeed may occur.*



*Up to 10 envelopes can be loaded into the tray at one time.*



*For envelopes with the flap along the long edge (Envelope C6 and Envelope DL), load the envelopes with the flap side inserted first.*

- 5** Slide the media guides against the edges of the envelopes.

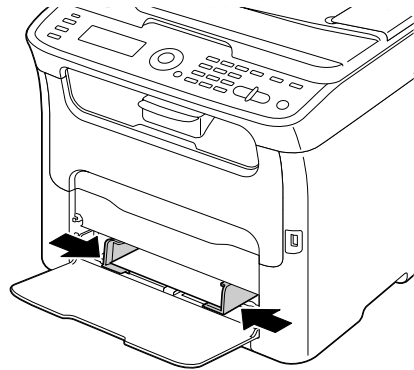
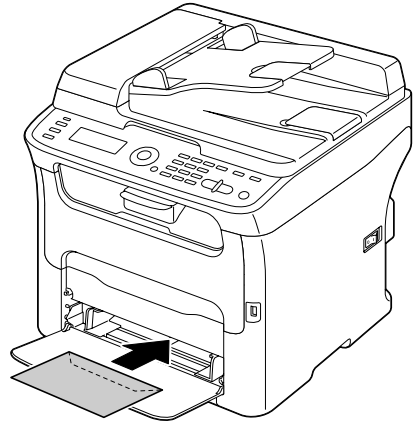



- 6 Install the dust cover.

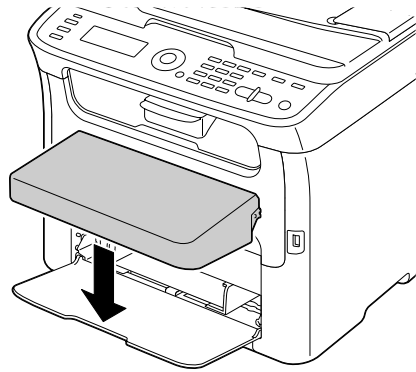

- 7 Select TRAY1 PAPER SETUP in the UTILITY menu, and then select the settings for the size and type of media that is loaded. See also “Print Media” on page 3-2.

### **Loading Label Sheets/Letterheads/Postcards and Thick Stock**

- 1 Remove the dust cover.

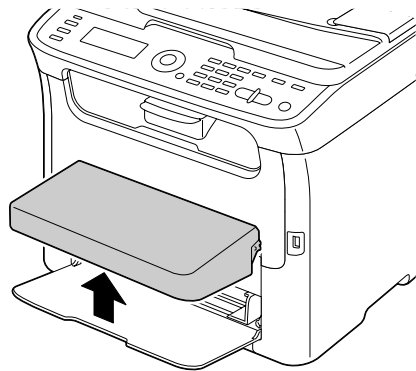

- 2 Remove any media in the tray.

- 3** Slide the media guides to provide more space between them.

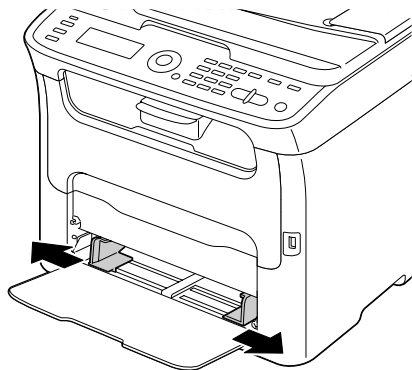

- 4** Load the media face up in the tray.



*Up to 50 sheets can be loaded into the tray at one time.*

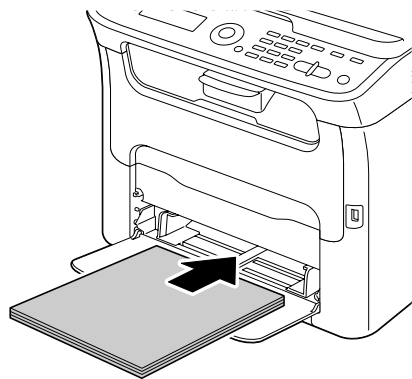

- 5** Slide the media guides against the edges of the media.

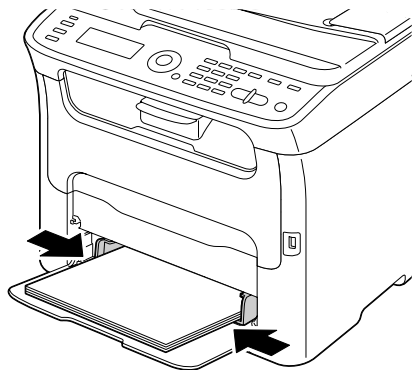

**6** Install the dust cover.

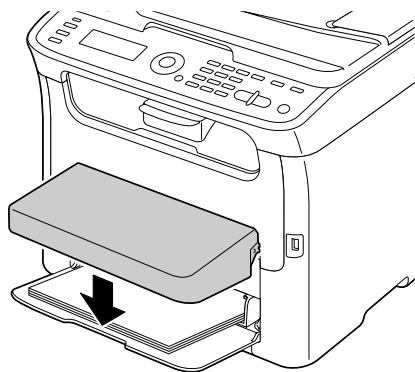

**7** Select **TRAY1 PAPER SETUP** in the **UTILITY** menu, and then select the settings for the size and type of media that is loaded. See also “Print Media” on page 3-2.

## Tray 2



*Only Letter/A4 plain paper can be loaded in Tray 2.*

### Loading Plain Paper

- 1 Pull out Tray 2 as far as possible.

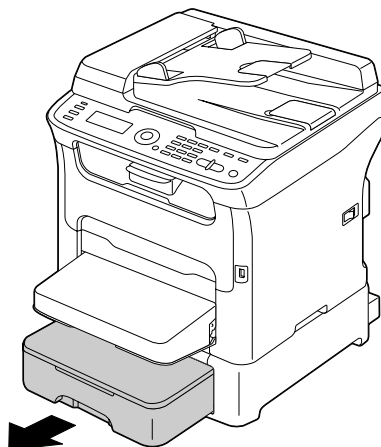

- 2 Lift up Tray 2 to remove it.

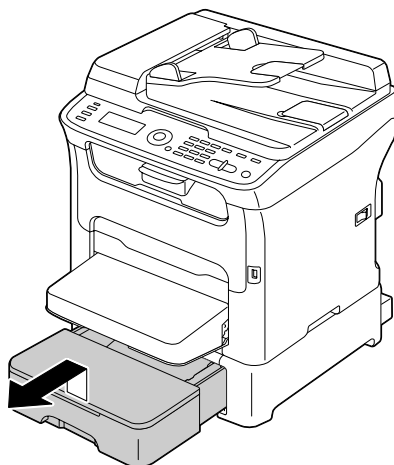

- 3** Remove the lid from Tray 2.

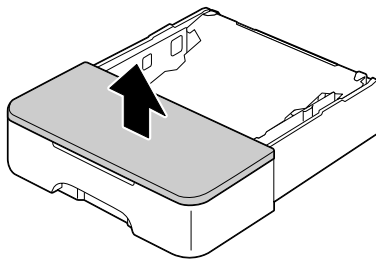

- 4** Press down the media pressure plate to lock it into place.

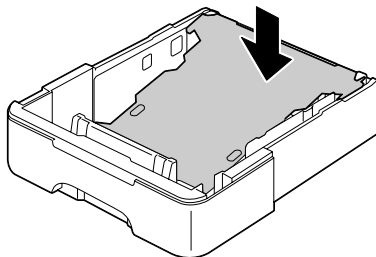

- 5** Load the paper face up in the tray.

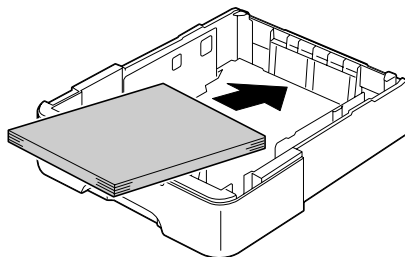

*Do not load above the 100% line. Up to 500 sheets (80 g/m<sup>2</sup> [21 lb]) of plain paper can be loaded into the tray at one time.*

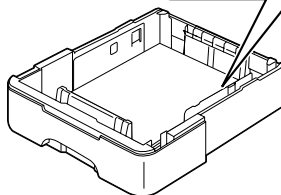
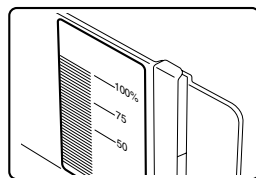

**6** Reattach the lid to Tray 2.

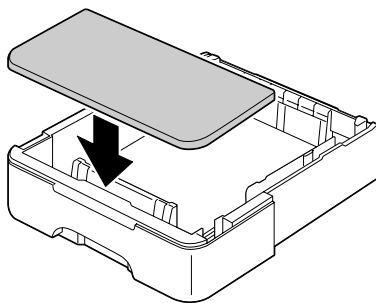

**7** Reinsert Tray 2 into the machine.

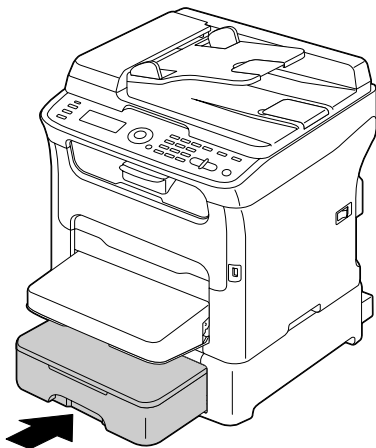

# About Duplex Printing

Duplex (double-sided) printing can be performed when the duplex option has been installed on this machine.



*For details on installing the duplex option, refer to “Duplex Option” on page 10-7.*

If the paper has low opacity (high translucency), then the printed data from one side of the page will show through to the other side. Check your application for margin information. For best results, print a small quantity to make sure the opacity is acceptable.

---

## Note

---

**Only Letter/A4 plain paper, 60–90 g/m<sup>2</sup> (16–24 lb bond) can be autoduplexed. See “Print Media” on page 3-2.**

**Duplexing envelopes, labels, letterheads, postcards or thick stock is not supported.**

---

## How do I autoduplex?

Check your application to determine how to set your margins for duplex (double-sided) printing.

The following Binding Position settings are available.

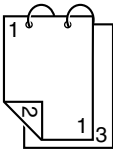
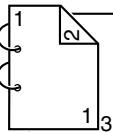
	If “Short Edge Binding” is selected, the pages will be laid out to flip at the top.
	If “Long Edge Binding” is selected, the pages will be laid out to flip at the side.

In addition, if “Combination” has been set to “Booklet”, autoduplex printing is performed.

The following Order settings are available when “Booklet” is selected.

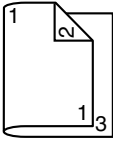
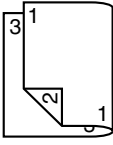
 A diagram showing a sheet of paper being folded into a booklet. The top-left corner is labeled '1', the top-right corner is labeled '2', and the bottom-right corner is labeled '3'. The paper is shown in a perspective view, folded along the top and right edges.	If “Left Binding” is selected, the pages can be folded as a left-bound booklet.
 A diagram showing a sheet of paper being folded into a booklet. The top-left corner is labeled '3', the top-right corner is labeled '1', and the bottom-right corner is labeled '2'. The paper is shown in a perspective view, folded along the top and right edges.	If “Right Binding” is selected, the pages can be folded as a right-bound booklet.

- 1 Load plain paper into the tray.
- 2 From the printer driver, specify duplex (double-sided) printing (Layout tab in Windows).
- 3 Click **OK**.



*With autoduplexing, the back side is printed first, and then the front side is printed.*



# Output Tray

The printed media is fed out facing down into the output tray below the control panel. This tray has a capacity of approximately 100 sheets (A4/Letter) of 80 g/m<sup>2</sup> paper.



*If the media is stacked too high in the output tray, your machine may experience media misfeeds, excessive media curl, or static buildup.*

The output tray can be pulled out to be extended. Adjust the output tray according to the size of paper to be printed on.

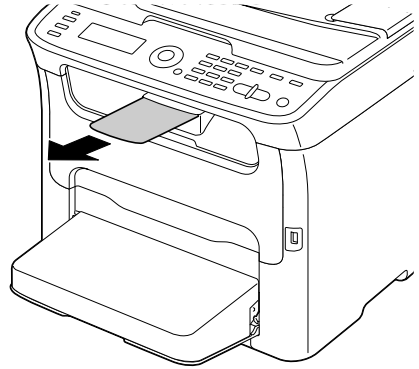

# Media Storage

- Keep media on a flat, level surface in its original wrapper until it is time to load it.

*Media that has been stored for a long time out of its packaging may dry up too much and cause misfeeding.*

- If media has been removed from its wrapper, place it in its original packaging and store in a cool, dark place on a level surface.
- Avoid moisture, excessive humidity, direct sunlight, excessive heat (above 35°C [95°F]), and dust
- Avoid leaning against other objects or placing it in an upright position.

Before using stored media, do a trial print and check print quality.

# Original Media

## Specifications

### Documents that can be placed on the original glass

The following types of documents can be placed on the original glass.

Document type	Sheets or books
Maximum document size	A4 or Letter
Maximum weight	3 kg (6.6 lb)

Observe the following precautions when placing a document on the original glass.

- Do not place objects weighing more than 3 kg (6.6 lb) on the original glass; otherwise the glass may be damaged.
- Do not press down extremely hard on a book spread on the original glass; otherwise the original glass may be damaged.

### Documents that can be loaded into the ADF

The following types of documents can be loaded into the ADF.

Document media type / Weight	Plain paper / 50 to 110 g/m <sup>2</sup> (13 to 29 lb)
Maximum document size	Legal
Media capacity	35 sheets (media weight: 80 g/m <sup>2</sup> )

Do not load the following types of documents into the ADF.

- Documents containing pages of different sizes
- Wrinkled, folded, curled, or torn documents
- Highly translucent or transparent documents, such as overhead transparencies or diazo photosensitive paper
- Coated documents such as carbon-backed paper
- Documents printed on paper thicker than 110 g/m<sup>2</sup> (29 lb)
- Documents with pages bound together with paper clips or staples
- Documents that are bound in a book or booklet
- Documents with pages bound together with glue

- Documents with pages that have had cutouts removed or are cutouts
- Label sheets
- Offset printing masters
- Documents with binder holes

# Loading a Document to be Copied

## Placing a document on the original glass

1 Lift to open the ADF cover.

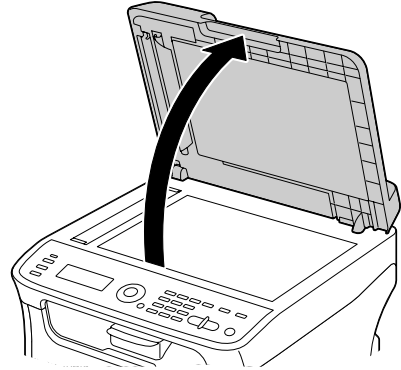

2 Position the document on the original glass.

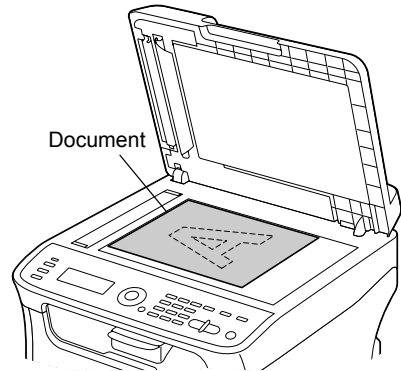

*Align the document with the arrow on the left side toward the rear of the machine.*

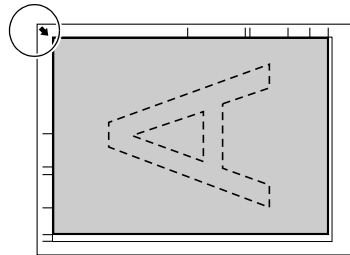

- 3 Gently close the ADF cover.

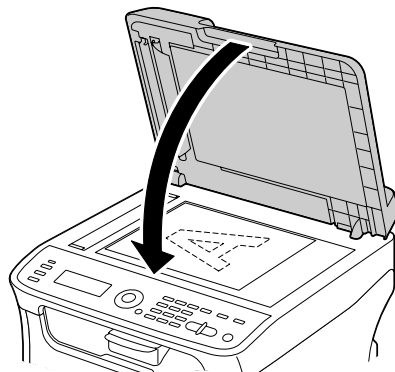

## Loading a document into the ADF

- 1 Put the document into the ADF document feed tray face up.



*Before loading a document into the ADF, check that no document pages remain on the original glass.*



*Load the document pages so that the top of the document is toward the back or the right side of the machine.*

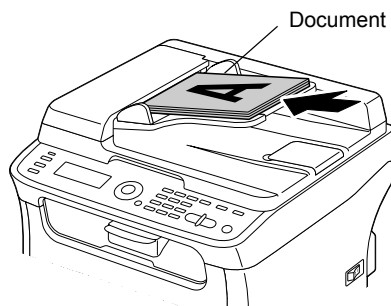

- 2 Adjust the document guides to the document size.

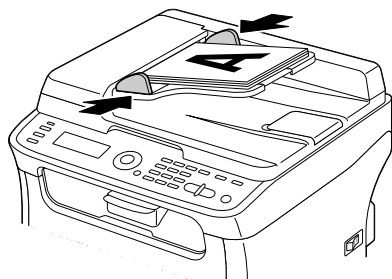

*For details on copying the loaded document, refer to “Using the Copier” on page 5-1. For details on scanning, refer to “Using the Scanner” on page 6-1.*



# *Using the Printer Driver* **4**





# Selecting Printer Driver Options/Defaults (for Windows)

Before you start working with your machine, you are advised to verify and change the default printer driver settings if necessary.

- 1 Choose the driver's properties as follows:
  - (Windows Vista)  
From the **Start** menu, select **Control Panel**, and then click **Hardware and Sound** to select **Printers**. Right-click the KONICA MINOLTA magicolor 1690MF printer icon, and then select **Printing Preferences**.
  - (Windows XP/Server 2003)  
From the **start** menu, select **Printers and Faxes** to display the **Printers and Faxes** directory. Right-click the KONICA MINOLTA magicolor 1690MF printer icon and select **Printing Preferences**.
  - (Windows 2000)  
From the **Start** menu, select **Settings** and then **Printers** to display the **Printers** directory. Right-click the KONICA MINOLTA magicolor 1690MF printer icon and select **Printing Preferences**.
- 2 Select the **Basic** tab. Select the default settings for your machine, such as the default media format you use.
- 3 Click **Apply**.
- 4 Click **OK** to exit from the Printing Preferences dialog box.

# Uninstalling the Printer Driver (for Windows)

This section describes how to uninstall the printer driver if necessary.



*You must have administrator privileges in order to uninstall the printer driver.*



*If the User Account Control window appears when uninstalling on Windows Vista, click the **Allow** button or the **Continue** button.*

## Windows Vista/XP/Server 2003/2000

- 1 Close all applications.
- 2 Choose Uninstall Program as follows:
  - (Windows Vista/XP/Server 2003)  
From the **Start** menu, choose **All programs, KONICA MINOLTA, magicolor 1690MF, Printer**, and then **Uninstall**.
  - (Windows 2000)  
From the **Start** menu, choose **Program, KONICA MINOLTA, magicolor 1690MF, Printer**, and then **Uninstall**.
- 3 When the Uninstall dialog box appears, select the printer to be deleted, and then click **Uninstall** button.
- 4 The printer driver will be uninstalled from your computer.

## Displaying Printer Driver Settings

### Windows Vista

- 1 From the **Start** menu, select **Control Panel**, and then click **Hardware and Sound** to select **Printers**.
- 2 Right-click the KONICA MINOLTA magicolor 1690MF printer icon then select **Printing Preferences**.

### Windows XP/Server 2003

- 1 From the **start** menu, select **Printers and Faxes** to display the **Printers and Faxes** directory.
- 2 Right-click the KONICA MINOLTA magicolor 1690MF printer icon and select **Printing Preferences**.

## Windows 2000

- 1 From the **Start** menu, select **Settings**, and then click **Printers** to display the **Printers** directory.
- 2 Right-click the KONICA MINOLTA magicolor 1690MF printer icon and select **Printing Preferences**.

# Printer Driver Settings

## Common Buttons

The buttons described below appear on each tab.

- OK

Click to exit the Properties dialog box, saving any changes made.

- Cancel

Click to exit the Properties dialog box without saving any changes made.

- Apply

Click to save all changes without exiting the Properties dialog box.

- Help

Click to view the help.

- Easy Set

Click **Save** to save the current settings. Specify a **Name** and **Comment** to access the settings for use again later.

**Name:** Type in the name of the settings to be saved.

**Comment:** Add a simple comment to the settings to be saved.

Afterward, the saved settings can be selected from the drop-down list. To change the registered settings, click **Edit**.

Select **Default** from the drop-down list to reset the functions in all tabs to their default values.

- Printer View

Click the button to display an image of the printer in the figure area.

When this button is clicked, it changes to the **Paper View** button (when a tab other than the **Watermark** tab or **Quality** tab is selected), the **Watermark View** button (when the **Watermark** tab is selected), or the **Quality View** button (when the **Quality** tab is selected).



*This button does not appear on the **Version** tab.*

- Paper View

Click the button to display a sample of the page layout in the figure area.

When this button is clicked, it changes to the **Printer View** button.



*This button does not appear on the **Watermark**, **Quality** and **Version** tabs.*

### ■ Watermark View

Click the button to display a preview of the watermark.

When this button is clicked, it changes to the **Printer View** button.



*This button appears only when the **Watermark** tab is selected.*

### ■ Quality View

Click the button to display a sample of the settings selected in the **Quality** tab.

When this button is clicked, it changes to the **Printer View** button.



*This button appears only when the **Quality** tab is selected.*

### ■ Default

Click the button to reset the settings to their defaults.



*This button does not appear on the **Version** tab.*



*When this button is clicked, the settings in the displayed dialog box are reset to their defaults. The settings on other tabs are not changed.*

## Basic Tab

The Basic Tab allows you to

- Specify the orientation of the media
- Specify the size of the original document
- Select the output media size
- Register/edit custom paper sizes
- Zoom (expand/reduce) documents
- Specify the number of copies
- Turn on/off job collation
- Specify the paper source
- Specify the type of media
- Select the paper used for the front page

## Layout Tab

The Layout Tab allows you to

- Print several pages of a document on the same page (N-up printing)
- Specify booklet printing (when the duplex option is installed)
- Print a single copy for enlargement and print several pages
- Rotate the print image 180 degrees
- Specify Double-Sided printing (when the duplex option is installed)
- Specify image shift settings

## Overlay Tab



*Be sure to use overlays with print jobs with a media size and orientation that matches the overlay form.*

*In addition, if settings have been specified for “N-up” or “Booklet” in the printer driver, the overlay form cannot be adjusted to match the specified settings.*

The Overlay Tab allows you to

- Select the form Overlay to use
- Add, edit or delete overlay files
- Print the form on all pages or only the first page

## Watermark Tab

The Watermark Tab allows you to

- Select the watermark to be used
- Add, edit or delete watermarks
- Print the watermark on the background
- Print the watermark on only the first page
- Print multiple copies of the selected watermark on a single page

## Quality Tab

The Quality Tab allows you to

- Specify whether to print in color or black and white
- Specify the color matching for printing documents
- Specify the resolution for the printout
- Select whether or not economy print is used

- Adjust the contrast (Contrast)
- Control the darkness of an image (Brightness)
- Adjust the saturation of printed image (Saturation)
- Adjust the sharpness of the printed image (Sharpness)

## **Version Tab**

- The Version Tab allows you to view information about the printer driver.

*Using the Copier* **5**





# Making Basic Copies

This section contains descriptions of the basic copy operation procedure and the functions that are frequently used when making copies, such as specifying the zoom ratio and the copy density.



*Before making copies, check that the **Copy** key is lit up in green. If the key is not lit up in green, press the **Copy** key to enter Copy mode.*



*The default paper size setting can be changed with TRAY1 PAPER SETUP in the UTILITY menu. For details, refer to “TRAY1 PAPER SETUP Menu” on page 2-26.*

If, while specifying settings, no key is pressed for the length of time specified for AUTO PANEL RESET, the entered settings are canceled and the main screen (Copy mode) is displayed.

## Basic Copy Operation

- 1 Position the document to be copied.



*For details on positioning the document, refer to “Placing a document on the original glass” on page 3-28 and “Loading a document into the ADF” on page 3-29.*

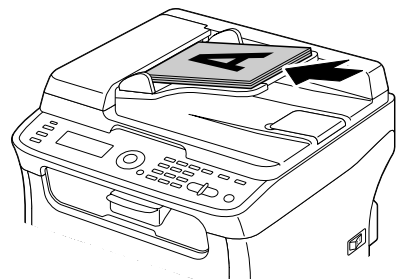
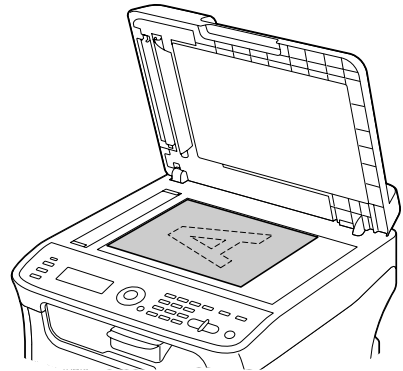

- 2 Press the **Copy** key.
- 3 Specify the desired copy settings.



*For details on specifying the copy mode and the copy density, refer to “Specifying the Copy Quality Setting” on page 5-3.*

*For details on specifying the zoom ratio, refer to “Specifying the Zoom Ratio” on page 5-4.*

*For details on selecting the media tray, refer to “Selecting the Media Tray” on page 5-5.*

*For details on setting 2in1 copying, refer to “Setting 2in1 Copying” on page 5-6.*

*For details on ID card copying, repeat copying or poster copying, refer to “Setting a Copy Function” on page 5-7.*

*For details on duplex (double-sided) copying, refer to “Setting Duplex (Double-Sided) Copying” on page 5-11.*

*For details on setting collated copying, refer to “Setting Collated (Sort) Copying” on page 5-13.*

- 4 Using the keypad, specify the desired number of copies.



*If the number of copies was incorrectly entered, press the **Back** key, and then specify the correct number of copies.*

- 5 To print color copies, press the **Start-Color** key. To print monochrome copies, press the **Start-B&W** key.

*Copying begins.*



*If the **Stop/Reset** key is pressed while copying, **JOB CANCEL** appears. To stop copying, select **YES**. To continue copying, select **NO**.*

## Specifying the Copy Quality Setting

Select the document type and copy density appropriate for the contents and density of the document to be copied.

### Selecting the Document Type

- 1 In the main screen (Copy mode), press the ▲ or ▼ key to select the current copy quality setting, and then press the **Select** key.
- 2 Press the ▲ or ▼ key to select **MODE**, and then press the **Select** key.
- 3 Press the ▲ or ▼ key to select **MIX**, **TEXT**, **PHOTO**, **FINE/MIX**, **FINE/TEXT** or **FINE/PHOTO**, and then press the **Select** key.  
The main screen (Copy mode) appears again.

## Specifying the Copy Density

- 1 In the main screen (Copy mode), press the ▲ or ▼ key to select the current copy quality setting, and then press the **Select** key.
- 2 Press the ▲ or ▼ key to select DENSITY, and then press the **Select** key.
- 3 Press the ◀ or ▶ key to select the desired copy density, and then press the **Select** key.

As the indicator is moved to right, the density becomes darker.

The main screen (Copy mode) appears again.



*If TEXT or FINE/TEXT is selected as the copy mode, select either AUTO or MANUAL in step 3. If MANUAL is selected, specify the copy density.*

## Specifying the Zoom Ratio

The zoom ratio can be specified either by selecting a preset zoom ratio or by specifying a custom zoom ratio.

### Selecting a Preset Zoom Ratio

- 1 In the main screen (Copy mode), press the ▲ or ▼ key to select the current zoom ratio setting, and then press the **Select** key.
- 2 Press the ▲ or ▼ key to select FIXED, and then press the **Select** key.
- 3 Press the ▲ or ▼ key to select the desired zoom ratio, and then press the **Select** key.

The main screen (Copy mode) appears again.



*The following zoom ratios can be selected.*

*In metric dimensions:*

*50%, 70% (A4→A5), 81% (A4→B5), 100%, 115% (B5→A4), 141% (A5→A4), 200%*

*In inch dimensions:*

*50%, 64% (LT→ST), 78% (LG→LT), 100%, 129% (ST→LT), 154% (ST→LG), 200%*

*The zoom ratio cannot be changed using the keypad.*

### Specifying a Custom Zoom Ratio

- 1 In the main screen (Copy mode), press the ▲ or ▼ key to select the current zoom ratio setting, and then press the **Select** key.
- 2 Press the ▲ or ▼ key to select MANUAL, and then press the **Select** key.

- 3 Use the keypad to type in the desired zoom ratio, or press the ▲ or ▼ key to specify the zoom ratio, and then press the **Select** key.  
The main screen (Copy mode) appears again.



*Each press of the ▲ or ▼ key changes the zoom ratio by 1%.  
A setting between 50% and 200% can be specified.*

## Selecting the Media Tray



*If an optional lower feeder unit is not installed, this setting is not available.*

- 1 In the main screen (Copy mode), press the ▲ or ▼ key to select the current media tray setting, and then press the **Select** key.
- 2 Press the ▲ or ▼ key to select the desired media tray, and then press the **Select** key.  
The main screen (Copy mode) appears again.



*If no paper is loaded in Tray 2, **EMPTY** appears to the right of the media size.*

# Making Advanced Copies

This section contains descriptions on setting 2in1 copying, ID card copying, repeat copying, poster copying, duplex (double-sided) copying and collated (Sort) copying.



*ID card copying, repeat copying or poster copying cannot be set at the same time that 2in1 copying, duplex (double-sided) copying or collated (Sort) copying is set.*

## Setting 2in1 Copying

If 2in1 copying is set, two document pages can be copied together onto a single page.

### 2in1 Copying From the ADF

- 1 In the main screen (Copy mode), press the ▲ or ▼ key to select the current page layout setting, and then press the **Select** key.
- 2 Press the ▲ or ▼ key to select 2in1, and then press the **Select** key. The zoom ratio is automatically set according to the specified media size. Change the zoom ratio if necessary. The main screen (Copy mode) appears again.



*In order to perform duplex (double-sided) copying or collated (Sort) copying with 2in1 copying, specify the necessary settings before starting the copy operation. For details, refer to “Setting Duplex (Double-Sided) Copying” on page 5-11 and “Setting Collated (Sort) Copying” on page 5-13.*



*Do not set 2in1 copying while the ADF is lifted open, otherwise a malfunction will occur.*

### 2in1 Copying From the Original Glass

- 1 In the main screen (Copy mode), press the ▲ or ▼ key to select the current page layout setting, and then press the **Select** key.
- 2 Press the ▲ or ▼ key to select 2in1, and then press the **Select** key. The zoom ratio is automatically set according to the specified media size. Change the zoom ratio if necessary.
- 3 Position the first page of the document on the original glass.



*For details on positioning the document on the original glass, refer to “Placing a document on the original glass” on page 3-28.*

- 4 To print color copies, press the **Start-Color** key. To print monochrome copies, press the **Start-B&W** key. Scanning of the document begins.



*In order to perform duplex (double-sided) copying or collated (Sort) copying with 2in1 copying, specify the necessary settings before performing step 4. For details, refer to “Setting Duplex (Double-Sided) Copying” on page 5-11 and “Setting Collated (Sort) Copying” on page 5-13.*

- 5 When **NEXT PAGE?** appears in the message window, place the second document page on the original glass, and then press the **Select** key.
- 6 Repeat step 5 until all document pages have been scanned. If **2in1** is set, printing automatically begins after two document pages (four document pages if duplex (double-sided) copying was set) have been scanned.
- 7 After all document pages have been scanned, press the **Start-Color** key or the **Start-B&W** key to begin printing the remaining pages.

## Setting a Copy Function

ID card copying, repeat copying and poster copying can be set.



*If a copy function other than **NORMAL COPY** has been set, 2in1 copying, collated (Sort) copying and duplex (double-sided) copying cannot be set. In addition, the zoom ratio is automatically set (and cannot be changed).*



*ID card copying, repeat copying and poster copying can only be performed with the original glass. Position the document pages to be scanned so that they are aligned in the upper-left corner of the original glass. Since the image is printed 4 mm from the top and left side, adjust the position of the document as necessary. For details on positioning the document on the original glass, refer to “Placing a document on the original glass” on page 3-28.*

## ID Card Copying

With ID card copying, the back and front of a document, such as a certificate, are copied at full size on a single sheet of paper.

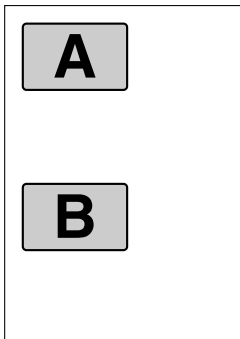
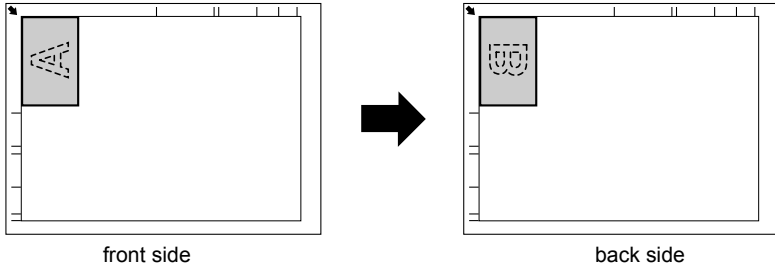

*The paper sizes that are available for ID card copying are A4, Letter and Legal.*

**1** Position the document on the original glass.



*For details on positioning the document on the original glass, refer to "Placing a document on the original glass" on page 3-28.*

**2** In the main screen (Copy mode), press the **▲** or **▼** key to select the current copy function setting, and then press the **Select** key.

**3** Press the **▲** or **▼** key to select ID CARD COPY, and then press the **Select** key.

**4** To print color copies, press the **Start-Color** key. To print monochrome copies, press the **Start-B&W** key.

*Scanning of the document begins.*

**5** When NEXT PAGE? appears, position the back side of the document at the same location as the front side, and then press the **Select** key.

*After the back side has been scanned, printing automatically begins.*



To print only the front sides that were scanned first, press the **Start-Color** key or the **Start-B&W** key in step 5.

## Repeat Copying

With repeat copying, small documents, such as memos, are tiled and printed on a single page.

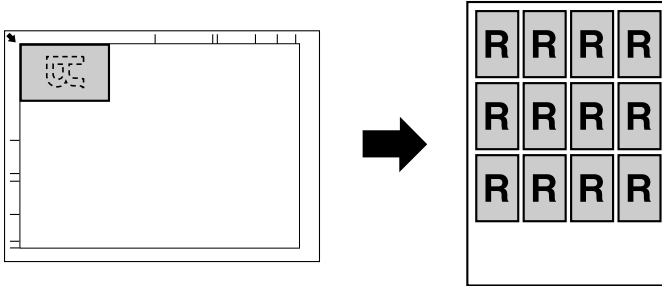

- 1 Position the document on the original glass.



For details on positioning the document on the original glass, refer to “Placing a document on the original glass” on page 3-28.

- 2 In the main screen (Copy mode), press the ▲ or ▼ key to select the current copy function setting, and then press the **Select** key.
- 3 Press the ▲ or ▼ key to select REPEAT COPY, and then press the **Select** key.
- 4 When the How to Repeat Copy screen appears, check the settings, and then press the **Select** key.
- 5 To print color copies, press the **Start-Color** key. To print monochrome copies, press the **Start-B&W** key.
- 6 Use the keypad to type in the document length, and then press the **Select** key.



To change the document size, press the **Back** key to delete the current size, and then use the keypad to specify the desired size.

- 7 Use the keypad to type in the document width, and then press the **Select** key.

After the document has been scanned, printing automatically begins.



To change the document size, press the **Back** key to delete the current size, and then use the keypad to specify the desired size.



## Poster Copying

With poster copying, the length and width of the scanned document are each enlarged 200%, and printed on four pages.



*If the scanned image does not fit on the size of paper that is used, there may be margins on the sides of the image or the image may not fit in the paper.*

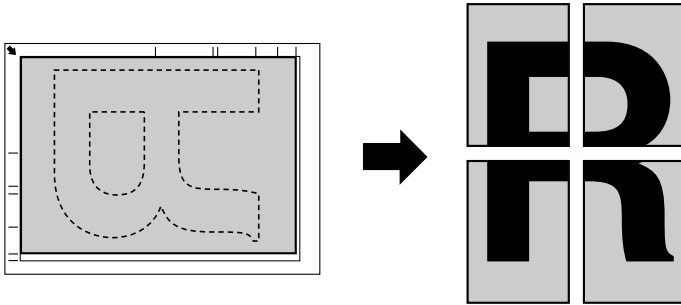

- 1 Position the document on the original glass.



*For details on positioning the document on the original glass, refer to "Placing a document on the original glass" on page 3-28.*

- 2 In the main screen (Copy mode), press the ▲ or ▼ key to select the current copy function setting, and then press the **Select** key.
- 3 Press the ▲ or ▼ key to select **POSTER COPY**, and then press the **Select** key.
- 4 To print color copies, press the **Start-Color** key. To print monochrome copies, press the **Start-B&W** key.  
After the document has been scanned, printing automatically begins.

## Setting Duplex (Double-Sided) Copying

In order to perform double-sided copying, the duplex option must be installed on the machine.



*For details on installing the duplex option, refer to "Duplex Option" on page 10-7.*

### Duplex (Double-Sided) Copying From the ADF

With duplex (double-sided) copying, two single-sided document pages can be scanned with the ADF and printed onto a single sheet of paper.

- 1 In the main screen (Copy mode), press the ▲ or ▼ key to select the current duplex setting, and then press the **Select** key.
- 2 Press the ▲ or ▼ key to select **LONG EDGE** or **SHORT EDGE**, and then press the **Select** key.  
The main screen (Copy mode) appears again.

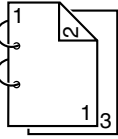
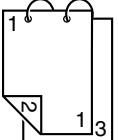

*When **LONG EDGE** or **SHORT EDGE** is selected, duplex copying is performed as described below.*

	If <b>LONG EDGE</b> is selected, the pages will be laid out to flip at the sides.
	If <b>SHORT EDGE</b> is selected, the pages will be laid out to flip at the top.

## Duplex (Double-Sided) Copying From the Original Glass

Duplex (double-sided) copying can also be performed by placing the document on the original glass.

- 1 Position the document on the original glass.



*For details on positioning the document on the original glass, refer to “Placing a document on the original glass” on page 3-28.*

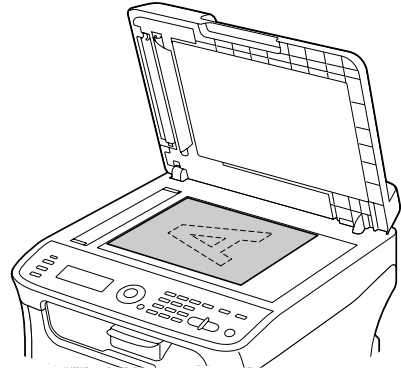

- 2 In the main screen (Copy mode), press the ▲ or ▼ key to select the current duplex setting, and then press the **Select** key.
- 3 Press the ▲ or ▼ key to select LONG EDGE or SHORT EDGE, and then press the **Select** key.



*For details on LONG EDGE and SHORT EDGE, refer to “Duplex (Double-Sided) Copying From the ADF” on page 5-11.*

- 4 To print color copies, press the **Start-Color** key. To print monochrome copies, press the **Start-B&W** key.

*Scanning of the document begins.*

- 5 When NEXT PAGE? appears in the message window, place the second document page on the original glass, and then press the **Select** key.

*After the second page (back side) is scanned, printing begins automatically.*

## Setting Collated (Sort) Copying

With collated (Sort) copying, multiple copies of multi-page documents can be printed in order and sorted by copy set.

### Collated (Sort) Copying From the ADF

- 1 In the main screen (Copy mode), press the ▲ or ▼ key to select the current Sort setting, and then press the **Select** key.
- 2 Press the ▲ or ▼ key to select **SORT**, and then press the **Select** key. The main screen (Copy mode) appears again.

### Collated (Sort) Copying From the Original Glass

- 1 Position the document on the original glass.



*For details on positioning the document on the original glass, refer to "Placing a document on the original glass" on page 3-28.*

- 2 In the main screen (Copy mode), press the ▲ or ▼ key to select the current Sort setting, and then press the **Select** key.
- 3 Press the ▲ or ▼ key to select **SORT**, and then press the **Select** key.
- 4 To print color copies, press the **Start-Color** key. To print monochrome copies, press the **Start-B&W** key.
- 5 When **NEXT PAGE?** appears in the message window, place the second document page on the original glass, and then press the **Select** key.
- 6 Repeat step 5 until all document pages have been scanned.
- 7 After all document pages have been scanned, specify the desired number of copies using the keypad, and then press the **Start-Color** key or the **Start-B&W** key to begin printing.



*Using the Scanner* **6**



# Scanning From a Computer Application

Documents can be scanned from a computer connected to this machine with a USB cable or via a network. Scanning settings can be specified and the scanning operation can be performed from TWAIN- or WIA-compatible applications. From the scanner driver, a preview can be displayed and various adjustments, such as the size of the scan area, can be specified.



*For details on the installation of the scanner driver or network TWAIN settings, refer to the Installation Guide.*

## Basic Scanning Operation

- 1 Position the document to be scanned.



*For details on positioning the document, refer to “Placing a document on the original glass” on page 3-28 and “Loading a document into the ADF” on page 3-29.*

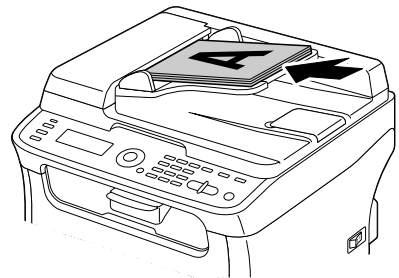
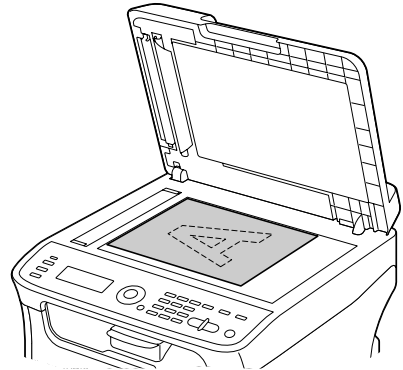

- 2 Start the application to be used for scanning.
- 3 Start the scanner driver according to the application settings.
- 4 Specify the necessary scanner driver settings.
- 5 Click the **Scan** button in the scanner driver.

## Windows TWAIN Driver Settings

- Load

Load a saved settings file (dat file) for scanning.

- Save

Save the current settings as a settings file (dat file).

- Default

Return all settings to their defaults.

- Help icon

Click to display the Help.

- About icon

Click to display the software version information.

- Paper source

Select whether documents are placed on the original glass or loaded into the ADF.

- Original Size

Specify the original size.

- Scan Type

Specify the scan type.

- Resolution

Specify the resolution.

- Scale

Specify the enlargement or reduction ratio for the selected area.



*If the resolution is set at 1200 × 1200dpi or higher, a setting larger than 100% cannot be specified.*

- Scanning mode

Select **Auto** or **Manual**. When **Manual** is selected, a tab appears so that detailed settings can be specified, for example, for **Brightness/Contrast** and **Filter**.



*The parameters that can be set differ depending on the scanning mode that is selected.*



*If **Auto** is selected as the scanning mode, scanning from the original glass is performed after a prescan is performed so that a preview image can be checked.*



- **Image size**

Shows the data size of the scan image.

- **Rotation**

Select the orientation of the image to be scanned.

- **Close**

Click to close the TWAIN driver window.

- **Prescan**

Click to begin scanning a preview image.

- **Scan**

Click to begin scanning.

- **AutoCrop icon**

Click to automatically detect the scanning position based on the preview image.

- **Zoom icon**

Click to rescan the area selected in the preview window and enlarge it to fit the window.

- **Mirror icon**

Click to display a mirror image of the preview image.

- **Tone Reversal icon**

Click to reverse the colors of the preview image.

- **Clear icon**

Click to erase the preview image.

- **Preview window**

Displays a preview image. Drag the rectangle over the image to select an area.

- **Before/After (RGB)**

Move the pointer in the preview window to display the color tones at the pointer's position before and after adjustments.

- **Width/Height**

Displays the width and height for the selected area in the selected measurement units.

## Windows WIA Driver Settings

- Paper source

Select whether documents are placed on the original glass or loaded into the ADF.

- Color picture

Select this setting when scanning in color.

- Grayscale picture

Select this setting when scanning in grayscale.

- Black and white picture or text

Select this setting when scanning in black and white.

- Custom Settings

Select this setting when scanning with **Adjust the quality of the scanned picture** settings applied.



*If settings have been specified with **Adjust the quality of the scanned picture**, **Custom Settings** is automatically selected.*

- Adjust the quality of the scanned picture

Click this message to display the Advanced Properties dialog box. In the Advanced Properties dialog box, settings can be specified for **Brightness**, **Contrast**, **Resolution**, and **Picture type** (select from color, grayscale, or black and white).



*These settings are applied when **Custom Settings** is selected.*

- Page size

Specify the paper size when **Page source** is set to **Document Feeder**.

- Preview window

Displays a preview image. Drag the rectangle over the image to select an area.

- Preview

Click to begin scanning a preview image.

- Scan

Click to begin scanning.

- Cancel

Click to close the WIA driver window.

## Macintosh TWAIN Driver Settings

- Load

Load a saved settings file (dat file) for scanning.

- Save

Save the current settings as a settings file (dat file).

- Default

Return all settings to their defaults.

- Help icon

Click to display the Help.

- About icon

Click to display the software version information.

- Paper source

Select whether documents are placed on the original glass or loaded into the ADF.

- Original Size

Specify the original size.

- Scan Type

Specify the scan type.

- Resolution

Specify the resolution.

- Scale

Specify the enlargement or reduction ratio for the selected area.



*If the resolution is set at 1200 × 1200dpi or higher, a setting larger than 100% cannot be specified.*

- Scanning mode

Select **Auto** or **Manual**. When **Manual** is selected, a tab appears so that detailed settings can be specified, for example, for **Brightness/Contrast** and **Filter**.



*The parameters that can be set differ depending on the scanning mode that is selected.*



*If **Auto** is selected as the scanning mode, scanning from the original glass is performed after a prescan is performed so that a preview image can be checked.*

- **Image size**

Shows the data size of the scan image.

- **Rotation**

Select the orientation of the image to be scanned.

- **Close**

Click to close the TWAIN driver window.

- **Prescan**

Click to begin scanning a preview image.

- **Scan**

Click to begin scanning.

- **AutoCrop icon**

Click to automatically detect the scanning position based on the preview image.

- **Zoom icon**

Click to rescan the area selected in the preview window and enlarge it to fit the window.

- **Mirror icon**

Click to display a mirror image of the preview image.

- **Tone Reversal icon**

Click to reverse the colors of the preview image.

- **Clear icon**

Click to erase the preview image.

- **Preview window**

Displays a preview image. Drag the rectangle over the image to select an area.

- **Before/After (RGB)**

Move the pointer in the preview window to display the color tones at the pointer's position before and after adjustments.

- **Width/Height**

Displays the width and height for the selected area in the selected measurement units.

# Scanning With the Machine

The machine keys can be used to make scans. This operation differs from scanning from a computer application since the destination of the scan data can also be specified.



*Before scanning, check that the **Scan** key is lit up in green. If the key is not lit up in green, press the **Scan** key to enter Scan mode.*



*If, while specifying settings, no key is pressed for the length of time specified for **AUTO PANEL RESET**, the entered settings are canceled and the main screen (Scan mode) is displayed.*

## Basic Scanning Operation

- 1 Position the document to be scanned.



*For details on positioning the document, refer to “Placing a document on the original glass” on page 3-28 and “Loading a document into the ADF” on page 3-29.*

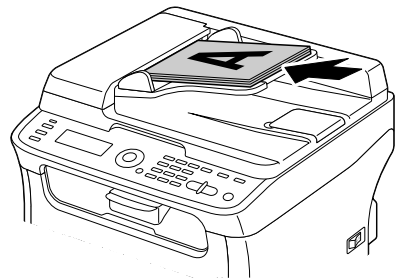
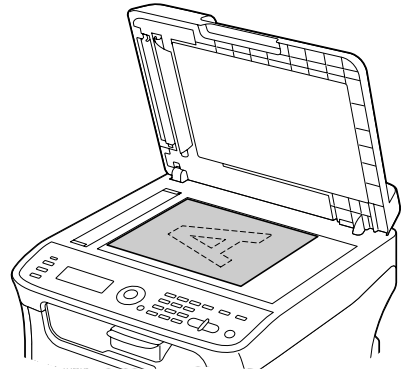

- 2 Press the **Scan** key to enter Scan mode.

### 3 Specify the desired scan settings.



*For details on specifying the destination of the data, refer to “Specifying the Data Location” on page 6-10 and “Specifying the Destination Address (Scan to E-mail/FTP/SMB)” on page 6-12.*

*For details on selecting the data format, refer to “Selecting the Data Format” on page 6-26.*

*For details on selecting the scan quality setting, refer to “Selecting the Scan Quality Setting” on page 6-27.*

*For details on setting the scan size, refer to “Setting the Scan Size” on page 6-28.*

*For details on setting the color of the scan data, refer to “Setting the Scan Color” on page 6-28.*

*For details on specifying the subject when sending data, refer to “Specifying the Subject” on page 6-28.*

### 4 To scan color scans, press the **Start-Color** key. To scan monochrome scans, press the **Start-B&W** key.

If the document was loaded in the ADF, scanning begins, and then the data is sent to the specified location. If the document was placed on the original glass, continue with step 5.



*Scanning with the Scan to PC operation is possible only if this machine is connected to a computer using a USB cable.*

### 5 When **NEXT PAGE?** appears in the message window, place the second document page on the original glass, and then press the **Select** key.



*When scanning with the Scan to PC operation, a multi-page document cannot be scanned with the original glass. To scan a multi-page document, load the document into the ADF.*

### 6 Press the **▲** or **▼** key to select the size of the document positioned in step 5, and then press the **Select** key.

### 7 After all document pages have been scanned, press the **Start** key. The scanned document is sent to the specified location.



*If the **Stop/Reset** key is pressed while scanning, **JOB CANCEL** appears. To continue scanning, select **NO**. To stop scanning, select **YES**.*



*To cancel a job where scanning was finished and the data is queued to be sent, refer to “Deleting a Queued Transmission Job” on page 6-29.*

## Specifying the Data Location

Select whether the computer or USB memory device is the location where scan data is to be saved. When transmitting via a network, refer to “Specifying the Destination Address (Scan to E-mail/FTP/SMB)” on page 6-12.



*If an address has been specified as the destination for the data, **SCAN TO PC** and **SCAN TO USB MEMORY** cannot be selected.*

## Saving Data on a Computer Connected (Scan to PC)

In order to perform Scan to PC operations, the following requirements must be met.

- This machine is connected to a computer using a USB cable.
- The TWAIN scanner driver, the printer driver and LinkMagic (Windows only) are installed on the computer.
- Either LinkMagic is activated or the LinkMagic icon appears in the Windows notification area.
- The document is positioned at the location specified with **Paper Source (Flatbed** (original glass) or **ADF**) in LinkMagic.



*For details on LinkMagic, refer to the Reference Guide on the Documentation CD/DVD.*

Follow the procedure described below to send scan data to a computer connected to this machine.



*The scan settings specified with LinkMagic are given priority. Specify the various settings with LinkMagic. For details, refer to the Reference Guide on the Documentation CD/DVD.*

- 1 In the main screen (Scan mode), press the ▲ or ▼ key to select **SCAN TO**, and then press the **Select** key.
- 2 Press the ▲ or ▼ key to select **SCAN TO PC**, and then press the **Select** key.



*The scan data is saved in the folder specified with LinkMagic. For details, refer to the Reference Guide on the Documentation CD/DVD.*

## Saving Data on a USB Memory Device (Scan to USB Memory)

Follow the procedure described below to save scan data to a USB memory device plugged into the USB memory port of this machine.



*This machine is compatible with a USB Host device of 4 GB or less.*

- 1** Plug the USB memory device into the USB Host port of this machine.
- 2** In the main screen (Scan mode), press the ▲ or ▼ key to select “SCAN TO”, and then press the **Select** key.
- 3** Press the ▲ or ▼ key to select SCAN TO USB MEMORY, and then press the **Select** key.



*Depending on the USB memory device that is used, it may take some time for the scan data to be transferred.*



# Specifying the Destination Address (Scan to E-mail/FTP/SMB)

Scan data can be sent via the network to a specified address (e-mail address, FTP address or SMB address). The address can be typed in directly, or an address registered on the machine can be selected.



*To send scan data via the network, settings for **NETWORK SETTING** and **E-MAIL SETTING** (when sending to an e-mail address) must be specified.*



*If the size of the scan data sent by e-mail exceeds the size specified with **FILE SIZE**, the data is automatically divided into multiple e-mail messages. For details, refer to "SCAN SETTING Menu" on page 2-52.*



*To save scan data in a shared folder on a computer installed with Windows or on the FTP server, the FTP address or SMB address must be registered as a speed dial destination. These addresses can be registered only from Local Setup Utility (LSU) or PageScope Web Connection. For details, refer to the Reference Guide on the Documentation CD/DVD.*

## Directly Entering the E-mail Address

The destination address (e-mail address) where the scan data is to be sent can be directly typed in.



*A maximum of 16 addresses (total of e-mail addresses from direct input and an LDAP search) can be specified.*

- 1 In the main screen (Scan mode), use the keypad to type in the destination address.



*For details on entering/editing text, refer to "Entering Text" on page A-6.*

- 2 After the text is entered, press the **Select** key.
- 3 If an e-mail address was selected, press the **▲** or **▼** key to select **FINISH**, and then press the **Select** key.



*To add an additional e-mail address, select **ADD** in step 3, and then specify the destination.*

*To edit the specified e-mail address, select **CHECK/EDIT** in step 3, and then continue with step 2 of "Editing a Specified Destination Address". To delete an address, select **CHECK/EDIT** in step 3, and then continue with step 2 of "Deleting a Specified Destination Address".*

## Selecting From the Favorite List

From the speed dial destinations and group dial destinations registered on this machine, register a maximum of 20 destinations in the favorite list for convenient access to frequently specified destinations. Follow the procedure described below to specify an address (e-mail address, FTP address or SMB address) from the favorite list as the recipient of the scan data.



*For details on registering addresses in the favorite list, refer to “Registering in the Favorite List” on page 6-20.*

- 1 With the main screen (Scan mode) or `Can Use AddressBook` displayed, press the **AddressBook** key so that `FAVORITE` appears.
- 2 Press the **▲** or **▼** key to select the desired data, and then press the **Select** key.
- 3 Press the **Select** key again.  
If an FTP address or an SMB address was selected, the destination address is specified.
- 4 If an e-mail address was selected, press the **▲** or **▼** key to select `FINISH`, and then press the **Select** key.



*To add an additional e-mail address, select `ADD` in step 4, and then specify the destination. When sending the data to an FTP address or SMB address, multiple addresses cannot be specified. To check the specified e-mail address, select `CHECK/EDIT` in step 4. To delete an address, select `CHECK/EDIT` in step 4, and then continue with step 2 of “Deleting a Specified Destination Address”.*

## Selecting a Speed Dial Destination

A maximum of 250 speed dial destinations can be registered on this machine. Follow the procedure described below to specify an address (e-mail address, FTP address or SMB address) from the registered speed dial destinations as the recipient of the scan data.



*For details on registering addresses as speed dial destinations, refer to “Registering Speed Dial Destinations (Direct Input)” on page 6-21 or “Registering Speed Dial Destinations (LDAP Search)” on page 6-22.*

- 1 With the main screen (Scan mode) or `Can Use AddressBook` displayed, press the **AddressBook** key twice so that `SPEED DIAL` appears.
- 2 Use the keypad to type in the number (between 1 and 250) for the speed dial destination, and then press the **Select** key.

The information registered for the speed dial destination appears for two seconds.

- 3 Press the **Select** key again.  
If an FTP address or an SMB address was selected, the destination address is specified.
- 4 If an e-mail address was selected, press the ▲ or ▼ key to select FINISH, and then press the **Select** key.



*To add an additional e-mail address, select ADD in step 4, and then specify the destination. When sending the data to an FTP address or SMB address, multiple addresses cannot be specified. To check the specified e-mail address, select CHECK/EDIT in step 4. To delete an address, select CHECK/EDIT in step 4, and then continue with step 2 of "Deleting a Specified Destination Address".*

## Selecting a Group Dial Destination

A maximum of 20 group dial destinations can be registered on this machine. (A maximum of 50 e-mail addresses can be registered with one group.) Follow the procedure described below to specify e-mail addresses from the registered group dial destinations as the recipient of the scan data.



*For details on registering e-mail addresses as group dial destinations, refer to "Registering Group Dial Destinations" on page 6-24.*



*A group dial destination containing a telephone number cannot be used in Scan mode.*

- 1 With the main screen (Scan mode) or Can Use AddressBook displayed, press the **AddressBook** key three times so that GROUP DIAL appears.
- 2 Use the keypad to type in the number (between 1 and 20) for the group dial destination, and then press the **Select** key.  
The information registered for the group dial destination appears for two seconds.
- 3 Press the **Select** key again.
- 4 Press the ▲ or ▼ key to select FINISH, and then press the **Select** key.



*To add an additional e-mail address, select ADD in step 4, and then specify the destination. To check the specified e-mail address, select CHECK/EDIT in step 4. To delete an address, select CHECK/EDIT in step 4, and then continue with step 2 of "Deleting a Specified Destination Address".*

## Selecting From the Address Book

The speed dial destinations and group dial destinations registered on this machine are saved in the address book. Follow the procedure described below to specify an address (e-mail address, FTP address or SMB address) from the address book as the recipient of the scan data.



*This feature is available only if data has been registered in the address book.*

- 1 With the main screen or **Can Use AddressBook** displayed, press the **AddressBook** key four times so that **PHONE BOOK** appears.
- 2 Press the **▲** or **▼** key to select **LIST**, and then press the **Select** key. A list of the address book contents appears.
- 3 Press the **▲** or **▼** key to select the desired data, and then press the **Select** key.
- 4 Press the **Select** key again. If an FTP address or an SMB address was selected, the destination address is specified.
- 5 If an e-mail address was selected, press the **▲** or **▼** key to select **FINISH**, and then press the **Select** key.



*To add an additional e-mail address, select **ADD** in step 5, and then specify the destination. When sending the data to an FTP address or SMB address, multiple addresses cannot be specified. To check the specified e-mail address, select **CHECK/EDIT** in step 5. To delete an address, select **CHECK/EDIT** in step 5, and then continue with step 2 of "Deleting a Specified Destination Address".*

## Searching the Address Book

The destination address (e-mail address, FTP address or SMB address) where the scan data is to be sent can be specified by searching the address book.



*This feature is available only if data has been registered in the address book.*

- 1 With the main screen (Scan mode) or **Can Use AddressBook** displayed, press the **AddressBook** key four times so that **PHONE BOOK** appears.
- 2 Press the **▲** or **▼** key to select **SEARCH**, and then press the **Select** key.
- 3 Use the keypad to type in the search keyword (maximum of 10 characters), and then press the **Select** key.

The search begins, and the search results appear after a while. If no data matches the search keyword, **NOT FOUND** appears for about two seconds.



*For details on entering/editing text, refer to “Entering Text” on page A-6.*



*Text starting with the first character of the maximum 10 characters is searched for. Text will not be found if the search keyword is in the middle of a word.*

- 4 Press the **▲** or **▼** key to select the desired data, and then press the **Select** key.



*To narrow down the search results, press the **Back** key, and then perform step 3 again.*

- 5 Press the **Select** key again.  
If an FTP address or an SMB address was selected, the destination address is specified.

- 6 If an e-mail address was selected, press the **▲** or **▼** key to select **FINISH**, and then press the **Select** key.



*To add an additional e-mail address, select **ADD** in step 6, and then specify the destination. When sending the data to an FTP address or SMB address, multiple addresses cannot be specified. To check the specified e-mail address, select **CHECK/EDIT** in step 6. To delete an address, select **CHECK/EDIT** in step 6, and then continue with step 2 of “Deleting a Specified Destination Address”.*

## Searching an LDAP Server

The destination e-mail address where the scan data is to be sent can be specified by using information on the LDAP server.



*To connect to an LDAP server, settings for **LDAP SETTING** must be specified. For details, refer to the Reference Guide on the Documentation CD/DVD.*



*A maximum of 16 addresses (total of addresses from direct input and an LDAP search) can be specified.*



*If anonymous access is used to search for information on an LDAP server, the correct search results may not be retrieved.*

- 1 With the main screen (Scan mode) or **Can Use AddressBook** displayed, press the **AddressBook** key four times so that **PHONE BOOK** appears.

- 2 Press the ▲ or ▼ key to select LDAP SEARCH, and then press the **Select** key.
- 3 Press the ▲ or ▼ key to select NAME or E-MAIL, and then press the **Select** key.



*To search registered names, select NAME. To search e-mail addresses, select E-MAIL.*

- 4 Use the keypad to type in the search keyword (maximum of 10 characters), and then press the **Select** key.  
The search begins, and the search results appear after a while. If no data matches the search keyword, NOT FOUND appears for about two seconds.



*For details on entering/editing text, refer to “Entering Text” on page A-6.*



*Text starting with the first character of the maximum 10 characters is searched for. Text will not be found if the search keyword is in the middle of a word.*

- 5 Press the ▲ or ▼ key to select the desired data, and then press the **Select** key.



*To check the found information, press the ► key.*



*An e-mail address exceeding 64 characters cannot be specified. If such an e-mail address is specified, ADDRESS IS TOO LONG appears for about two seconds, and then the screen for specifying the destination address appears.*



*To narrow down the search results, press the **Back** key, and then perform step 4 again.*

- 6 Press the **Select** key again.

- 7 Press the ▲ or ▼ key to select FINISH, and then press the **Select** key.



*To add an additional e-mail address, select ADD in step 7, and then specify the destination.  
To edit the specified e-mail address, select CHECK/EDIT in step 7, and then continue with step 2 of “Editing a Specified Destination Address”.  
To delete a specified e-mail address, select CHECK/EDIT in step 7, and then continue with step 2 of “Deleting a Specified Destination Address”. The address cannot be edited.*

## Specifying Multiple Destination Addresses

A destination address can be added if a destination e-mail address is specified.



*If an FTP address or an SMB address was selected, multiple destination addresses cannot be specified.*

- 1 In the main screen (Scan mode), press the ▲ or ▼ key to select the current data destination setting, and then press the **Select** key.
- 2 Press the ▲ or ▼ key to select **ADD**, and then press the **Select** key.
- 3 Specify the destination address.



*For details on typing in an e-mail address, refer to “Directly Entering the E-mail Address” on page 6-12.*

*For details on selecting from the favorite list, refer to “Selecting From the Favorite List” on page 6-13.*

*For details on selecting a speed dial destination, refer to “Selecting a Speed Dial Destination” on page 6-13.*

*For details on selecting a group dial destination, refer to “Selecting a Group Dial Destination” on page 6-14.*

*For details on selecting from the address book, refer to “Selecting From the Address Book” on page 6-15.*

*For details on searching the address book, refer to “Searching the Address Book” on page 6-15.*

*For details on searching an LDAP server, refer to “Searching an LDAP Server” on page 6-16.*

## Editing a Specified Destination Address

A specified destination e-mail address can be edited.



*FTP addresses, SMB addresses and addresses registered as speed dial destinations or group dial destinations cannot be edited.*

- 1 In the main screen (Scan mode), press the ▲ or ▼ key to select the current data destination setting, and then press the **Select** key.
- 2 Press the ▲ or ▼ key to select **CHECK/EDIT**, and then press the **Select** key.
- 3 Press the ▲ or ▼ key to select the e-mail address to be edited, and then press the **Select** key.
- 4 Use the keypad to edit the e-mail address, and then press the **Select** key.



*For details on entering/editing text, refer to “Entering Text” on page A-6.*

- 5 To finish editing addresses, press the **Back** key.

- 6 Press the ▲ or ▼ key to select **FINISH**, and then press the **Select** key.

## Deleting a Specified Destination Address

A specified destination address (e-mail address, FTP address or SMB address) can be deleted.



*Changes made with this procedure will not be applied to the original data (speed dial destination, group dial destination, etc.).*

- 1 In the main screen (Scan mode), press the ▲ or ▼ key to select the current data destination setting, and then press the **Select** key.
- 2 To delete an e-mail address, press the ▲ or ▼ key to select **CHECK/EDIT**, and then press the **Select** key. Then, press the ▲ or ▼ key to select the address to be deleted. To delete an FTP address or SMB address, continue with step 3.
- 3 Press the **Stop/Reset** key.
- 4 Press the ▲ or ▼ key to select **YES**, and then press the **Select** key. The selected address is deleted.



*If all specified addresses are deleted, the main screen is displayed.*

- 5 To delete another address, repeat the procedure from step 2.
- 6 To finish deleting addresses, press the **Back** key.
- 7 Press the ▲ or ▼ key to select **FINISH**, and then press the **Select** key.

## Registering/Editing Addresses

Addresses can be registered/edited in the favorite list, as speed dial destinations or as group dial destinations.



*Addresses can also be registered/edited with PageScope Web Connection or with LSU (Local Setup Utility) on the enclosed Applications CD/DVD. For details, refer to the Reference Guide on the Documentation CD/DVD.*



*The same settings menu used to register/edit fax numbers is used to register/edit addresses. For details on registering/editing fax numbers, refer to the Facsimile User's Guide on the Documentation CD/DVD.*



## Registering in the Favorite List

From the speed dial destinations and group dial destinations registered on this machine, register a maximum of 20 destinations in the favorite list for convenient access to frequently specified destinations. Follow the procedure described below to register an address (e-mail address, FTP address or SMB address) on the favorite list.

- 1 In the main screen (Scan mode), press the ▲ or ▼ key to select **UTILITY**, and then press the **Select** key.
- 2 Press the ▲ or ▼ key to select **DIAL REGISTER**, and then press the **Select** key.
- 3 Press the ▲ or ▼ key to select **FAVORITE**, and then press the **Select** key.



*If data is already registered on the favorite list, continue with step 7 after completing step 3.*

- 4 Press the **AddressBook** key to switch between **SPEED DIAL** and **GROUP DIAL**.
- 5 Use the keypad to type in the number (between 1 and 250) for the speed dial destination or the number (between 1 and 20) for the group dial destination to be registered on the favorite list, and then press the **Select** key. The information registered for the selected speed dial destination or group dial destination appears.
- 6 Press the **Select** key again.
- 7 To register another address, press the ▲ or ▼ key to select **ADD**, press the **Select** key, and then repeat the procedure from step 4.
- 8 To finish registering addresses, press the ▲ or ▼ key to select **FINISH**, and then press the **Select** key.

## Deleting From the Favorite List

Registered information can be deleted from the favorite list.



*Changes made with this procedure will not be applied to the original data (speed dial destination, group dial destination, etc.).*

- 1 In the main screen (Scan mode), press the ▲ or ▼ key to select **UTILITY**, and then press the **Select** key.
- 2 Press the ▲ or ▼ key to select **DIAL REGISTER**, and then press the **Select** key.
- 3 Press the ▲ or ▼ key to select **FAVORITE**, and then press the **Select** key.

- 4 Press the ▲ or ▼ key to select CHECK/EDIT, and then press the **Select** key.
- 5 Press the ▲ or ▼ key to select the address to be deleted from the favorite list, and then press the **Stop/Reset** key.
- 6 Press the ▲ or ▼ key to select YES, and then press **Select** key. The selected address is deleted.
- 7 To delete another address, repeat the procedure from step 5.
- 8 To finish deleting addresses, press the **Back** key.
- 9 Press the ▲ or ▼ key to select FINISH, and then press the **Select** key.

## Registering Speed Dial Destinations (Direct Input)

E-mail addresses can be registered as speed dial destinations. A maximum of 250 speed dial destinations can be registered.



*Machine key operations cannot be used to register an FTP address or SMB address as a speed dial destination. These addresses can be registered with Local Setup Utility (LSU) or PageScope Web Connection. For details, refer to the Reference Guide on the Documentation CD/DVD.*



*Speed dial destination numbers 221 to 250 are reserved for registering FTP addresses and SMB address from Local Setup Utility (LSU) or PageScope Web Connection.*

- 1 In the main screen (Scan mode), press the ▲ or ▼ key to select UTIL-ITY, and then press the **Select** key.
  - 2 Press the ▲ or ▼ key to select DIAL REGISTER, and then press the **Select** key.
  - 3 Press the ▲ or ▼ key to select SPEED DIAL, and then press the **Select** key.
  - 4 Use the keypad to type in the number (between 1 and 220) for the speed dial destination, and then press the **Select** key.
  - 5 Press the ▲ or ▼ key to select MANUAL SETTING, and then press the **Select** key.
- 6 Use the keypad to type in the registration name, and then press the **Select** key.



*If an LDAP server is not specified, step 5 is skipped.*



*For details on entering/editing text, refer to "Entering Text" on page A-6.*



*A maximum of 20 characters can be entered.*

- 7 Use the keypad to type in the e-mail address, and then press the **Select** key.  
The settings are registered, and the DIAL REGISTER menu appears again.



*A maximum of 64 characters can be entered.*

## Registering Speed Dial Destinations (LDAP Search)

E-mail addresses can be registered as speed dial destinations by using information on the LDAP server. A maximum of 250 speed dial destinations can be registered.



*To connect to an LDAP server, settings for LDAP SETTING must be specified. For details, refer to the Reference Guide on the Documentation CD/DVD.*



*Machine key operations cannot be used to register an FTP address or SMB address as a speed dial destination. These addresses can be registered with Local Setup Utility (LSU) or PageScope Web Connection. For details, refer to the Reference Guide on the Documentation CD/DVD.*



*Speed dial destination numbers 221 to 250 are reserved for registering FTP addresses and SMB address from Local Setup Utility (LSU) or PageScope Web Connection.*

- 1 In the main screen (Scan mode), press the ▲ or ▼ key to select UTILITY, and then press the **Select** key.
- 2 Press the ▲ or ▼ key to select DIAL REGISTER, and then press the **Select** key.
- 3 Press the ▲ or ▼ key to select SPEED DIAL, and then press the **Select** key.
- 4 Use the keypad to type in the number (between 1 and 220) for the speed dial destination, and then press the **Select** key.
- 5 Press the ▲ or ▼ key to select LDAP SEARCH, and then press the **Select** key.



*If an LDAP server is not specified, LDAP SEARCH does not appear.*

- 6 Press the ▲ or ▼ key to select NAME or E-MAIL, and then press the **Select** key.



*To search registered names, select NAME. To search e-mail addresses, select E-MAIL.*

- 7 Use the keypad to type in the search keyword (maximum of 10 characters), and then press the **Select** key.  
The search begins, and the search results appear after a while. If no data matches the search keyword, **NOT FOUND** appears for about two seconds.



*For details on entering/editing text, refer to “Entering Text” on page A-6.*



*Text starting with the first character of the maximum 10 characters is searched for. Text will not be found if the search keyword is in the middle of a word.*

- 8 Press the **▲** or **▼** key to select the desired data, and then press the **Select** key.



*To check the found information, press the **▶** key.*



*An e-mail address exceeding 64 characters cannot be specified. If such an e-mail address is specified, **ADDRESS IS TOO LONG** appears for about two seconds, and then the screen for specifying the destination address appears.*



*To narrow down the search results, press the **Back** key, and then perform step 7 again.*

- 9 If desired, edit the registration name, and then press the **Select** key.
- 10 If desired, edit the e-mail address, and then press the **Select** key.  
The settings are registered, and the **DIAL REGISTER** menu appears again.

## Editing/Deleting Speed Dial Destinations

Information registered as a speed dial destination can be edited or deleted.



*Machine key operations cannot be used to edit/delete an FTP address or SMB address registered as a speed dial destination. These addresses can be edited/deleted with Local Setup Utility (LSU) or PageScope Web Connection. For details, refer to the Reference Guide on the Documentation CD/DVD.*

- 1 In the main screen (Scan mode), press the **▲** or **▼** key to select **UTILITY**, and then press the **Select** key.
- 2 Press the **▲** or **▼** key to select **DIAL REGISTER**, and then press the **Select** key.
- 3 Press the **▲** or **▼** key to select **SPEED DIAL**, and then press the **Select** key.

**4** Use the keypad to type in the number (between 1 and 220) for the speed dial destination to be edited/deleted, and then press the **Select** key. The information currently registered for the speed dial destination appears for two seconds.

**5** Press the ▲ or ▼ key to select **EDIT** to edit information or **DELETE** to delete the destination, and then press the **Select** key. If **DELETE** was selected, the settings are deleted, and the **DIAL REGISTER** menu appears again.

**6** Use the keypad to edit the registration name, and then press the **Select** key.



*For details on entering/editing text, refer to “Entering Text” on page A-6.*

**7** Use the keypad to edit the e-mail address, and then press the **Select** key. The edited settings are saved, and the **DIAL REGISTER** menu appears again.



*If the edited speed dial destination is registered in the favorite list or with a group dial destination, a confirmation message asking whether or not to keep the destination registered as it is appears after the operation in step 7 is performed. To keep the destination registered as it is, select **Yes**. To cancel the registration, select **No**.*

## Registering Group Dial Destinations

An e-mail address can be registered with a group dial destination. A maximum of 20 group dial destinations can be registered. (A maximum of 50 e-mail addresses can be registered with one group.)



*The addresses that can be registered as group dial destinations are limited to addresses registered as speed dial destinations or as other group dial destinations.*

**1** In the main screen (Scan mode), press the ▲ or ▼ key to select **UTILITY**, and then press the **Select** key.

**2** Press the ▲ or ▼ key to select **DIAL REGISTER**, and then press the **Select** key.

**3** Press the ▲ or ▼ key to select **GROUP DIAL**, and then press the **Select** key.

**4** Use the keypad to type in the number (between 1 and 20) for the group dial destination, and then press the **Select** key.

**5** Use the keypad to type in the group name, and then press the **Select** key.



*For details on entering/editing text, refer to “Entering Text” on page A-6.*

- 6 Use the keypad to type in the number (between 1 and 220) for the speed dial destination to be added to the group, and then press the **Select** key. The information registered for the selected speed dial destination appears.
- 7 Press the **Select** key again.
- 8 To register another speed dial destination, press the ▲ or ▼ key to select ADD, press the **Select** key, and then repeat the procedure from step 6.
- 9 To finish registering speed dial destinations, press the ▲ or ▼ key to select FINISH, and then press the **Select** key.

## Editing/Deleting Group Dial Destinations

Information registered with a group dial destination can be edited or deleted.

- 1 In the main screen (Scan mode), press the ▲ or ▼ key to select UTIL-ITY, and then press the **Select** key.
- 2 Press the ▲ or ▼ key to select DIAL REGISTER, and then press the **Select** key.
- 3 Press the ▲ or ▼ key to select GROUP DIAL, and then press the **Select** key.
- 4 Use the keypad to type in the number (between 1 and 20) for the group dial destination to be edited/deleted, and then press the **Select** key. The information currently registered for the group dial destination appears for about two seconds.
- 5 Press the ▲ or ▼ key to select EDIT to edit information or DELETE to delete the destination, and then press the **Select** key. If DELETE was selected, the settings are deleted, and the DIAL REGISTER menu appears again.
- 6 If desired, edit the group name, and then press the **Select** key.



*For details on entering/editing text, refer to “Entering Text” on page A-6.*

- 7 Press the ▲ or ▼ key to select ADD to add a speed dial destination, CHECK/EDIT to delete the destination or FINISH to finish editing, and then press the **Select** key. If FINISH was selected, the edited settings are saved, and the DIAL REGISTER menu appears again. If ADD was selected, continue with step 6 of “Registering Group Dial Destinations” on page 6-24. If CHECK/EDIT was selected, continue with step 8.
- 8 Press the ▲ or ▼ key to select the speed dial destination to be deleted, and then press the **Stop/Reset** key.



To check the settings for the selected speed dial destination, press the **Select** key.

- 9 Press the ▲ or ▼ key to select **Yes**, and then press the **Select** key.
- 10 After the speed dial destination is deleted, press the **Back** key.
- 11 To delete another speed dial destination, repeat the procedure from step 8.
- 12 To finish deleting speed dial destinations, press the ▲ or ▼ key to select **FINISH**, and then press the **Select** key.



*If the edited group dial destination is registered in the favorite list, a confirmation message asking whether or not to keep the destination registered as it appears after the operation in step 12 is performed. To keep the destination registered as it is, select **Yes**. To cancel the registration, select **No**.*

## Selecting the Data Format

The data format for the scanned image can be selected.

- 1 In the main screen (Scan mode), press the ▲ or ▼ key to select the current data format setting, and then press the **Select** key.
- 2 Press the ▲ or ▼ key to select **TIFF**, **PDF** or **JPEG**, and then press the **Select** key.  
The main screen (Scan mode) appears again.



*If **BW ONLY** was selected for the color setting, **JPEG** does not appear.*



*PDF data can be opened in Adobe Acrobat Reader.*



*TIFF files of images that have been scanned with the **Color** or **Gray** setting cannot be opened with the Windows Picture and FAX Viewer, which is included with Windows XP as a standard component. These files can be opened with image-processing applications such as PhotoShop, Microsoft Office Document Imaging or ACDsee.*

## Selecting the Scan Quality Setting

The resolution, scan mode and density appropriate for the scanned image can be selected.

### Selecting the Resolution

- 1 In the main screen (Scan mode), press the ▲ or ▼ key to select the current scan quality setting, and then press the **Select** key.
- 2 Press the ▲ or ▼ key to select RESOLUTION, and then press the **Select** key.
- 3 Press the ▲ or ▼ key to select 150x150dpi or 300x300dpi, and then press the **Select** key.  
The main screen (Scan mode) appears again.

### Selecting the Scan Mode

- 1 In the main screen (Scan mode), press the ▲ or ▼ key to select the current scan quality setting, and then press the **Select** key.
- 2 Press the ▲ or ▼ key to select MODE, and then press the **Select** key.
- 3 Press the ▲ or ▼ key to select MIX, TEXT or PHOTO, and then press the **Select** key.  
The main screen (Scan mode) appears again.

### Selecting the Scan Density

- 1 In the main screen (Scan mode), press the ▲ or ▼ key to select the current scan quality setting, and then press the **Select** key.
- 2 Press the ▲ or ▼ key to select DENSITY, and then press the **Select** key.
- 3 Press the ◀ or ▶ key to select the desired scan density, and then press the **Select** key.  
As the indicator is moved to right, the density becomes darker.



## Setting the Scan Size

The size of the scan data can be specified.



*The default setting is **LETTER** for USA and Canada, and **A4** for other countries.*

- 1 In the main screen (Scan mode), press the ▲ or ▼ key to select the current scan size setting, and then press the **Select** key.
- 2 Press the ▲ or ▼ key to select the desired size, and then press the **Select** key.  
The main screen (Scan mode) appears again.

## Setting the Scan Color

The color of the scan data can be specified.

- 1 In the main screen (Scan mode), press the ▲ or ▼ key to select the current scan color setting, and then press the **Select** key.
- 2 Press the ▲ or ▼ key to select **BW Only** or **COLOR** or **GRAY**, and then press the **Select** key.  
The main screen (Scan mode) appears again.



*If **JPEG** is selected as the data format, the scan color is set to **BW Only**, and the data format is automatically set to **PDF**.*



*Settings for **SCAN SETTING/CODING METHOD** in the **UTILITY** menu are available only if **BW Only** is selected.*

## Specifying the Subject

Specify the subject used when sending scan data as e-mail.

- 1 In the main screen (Scan mode), press the ▲ or ▼ key to select **SUBJECT**, and then press the **Select** key.
- 2 Use the keypad to type in the subject name, and then press the **Select** key.  
The main screen (Scan mode) appears again.



*For details on entering/editing text, refer to “Entering Text” on page A-6.*



*To erase the specified subject name, press the **Back** key.*

## Deleting a Queued Transmission Job

The list of jobs queued for transmission can be displayed, and a job can be deleted.

**1** In the main screen (Scan mode), press the ▲ or ▼ key to select CANCEL RESERV., and then press the **Select** key.

**2** Press the ▲ or ▼ key to select the job to be deleted, and then press the **Select** key.



*To check the information for the selected job, press the ► key.*



*If no jobs are queued for transmission, NONE appears.*

**3** Press the ▲ or ▼ key to select YES, and then press the **Select** key. The main screen (Scan mode) appears again.



***Replacing  
Consumables***

**7**



# Replacing Consumables

---

---

## Note

Failure to follow instructions as outlined in this manual could result in voiding your warranty.

---

---

---

---

## Note

If an error message (TONER OUT, I/C LIFE END, etc.) appears, print out the configuration page, and then check the status of the other consumables. For details on the error messages, refer to “Error Messages” on page 9-38. For details on printing the configuration page, refer to “Printing a Configuration Page” on page 9-3.

---

---

## About Toner Cartridges

Your machine uses four toner cartridges: black, yellow, magenta, and cyan. Handle the toner cartridges carefully to avoid spilling toner inside the machine or on yourself.



*Install only new toner cartridges in your machine. If a used toner cartridge is installed, then toner remaining amount may not be accurate.*



*The toner is nontoxic. If you get toner on your skin, wash it off with cool water and a mild soap. If you get toner on your clothes, lightly dust them off as best as you can. If some toner remains on your clothes, use cool, not hot water, to rinse the toner off.*



## CAUTION

**If you get toner in your eyes, wash it out immediately with cool water and consult a doctor.**

---

---



*Refer to the following URL for recycling information.*

*US: [printer.konicaminolta.com/products/recycle/index.asp](http://printer.konicaminolta.com/products/recycle/index.asp)*

*Europe: [cleanplanet-printer.konicaminoltaeurope.com/cleanplanet/choose.php](http://cleanplanet-printer.konicaminoltaeurope.com/cleanplanet/choose.php)*

*Other regions: [printer.konicaminolta.com](http://printer.konicaminolta.com)*

## Note

**Do not use refilled toner cartridges or unapproved toner cartridges. Any damage to the machine or quality problems caused by a refilled toner cartridge or an unapproved toner cartridge will void your warranty. No technical support is provided to recover from these problems.**

When replacing a toner cartridge, refer to the following table. For optimum print quality and performance, use only approved KONICA MINOLTA toner cartridges for your specific machine type, as listed in the table below. You can find your machine type and the toner cartridge part numbers on the consumables reorder label inside the ADF cover.

Machine Type	Machine Part Number	Toner Cartridge Type	Toner Cartridge Part Number
AM	A0HF 012	Standard-Capacity Toner Cartridge -Yellow (Y)	A0V3 05F
		Standard-Capacity Toner Cartridge -Magenta (M)	A0V3 0AF
		Standard-Capacity Toner Cartridge -Cyan (C)	A0V3 0GF
		High-Capacity Toner Cartridge - Black (K)	A0V3 01F
		High-Capacity Toner Cartridge - Yellow (Y)	A0V3 06F
		High-Capacity Toner Cartridge - Magenta (M)	A0V3 0CF
		High-Capacity Toner Cartridge - Cyan (C)	A0V3 0HF
EU	A0HF 022	Standard-Capacity Toner Cartridge -Yellow (Y)	A0V3 05H
		Standard-Capacity Toner Cartridge -Magenta (M)	A0V3 0AH
		Standard-Capacity Toner Cartridge -Cyan (C)	A0V3 0GH
		High-Capacity Toner Cartridge - Black (K)	A0V3 01H
		High-Capacity Toner Cartridge - Yellow (Y)	A0V3 06H
		High-Capacity Toner Cartridge - Magenta (M)	A0V3 0CH
		High-Capacity Toner Cartridge - Cyan (C)	A0V3 0HH
AP	A0HF 042	Standard-Capacity Toner Cartridge -Yellow (Y)	A0V3 05K
		Standard-Capacity Toner Cartridge -Magenta (M)	A0V3 0AK
		Standard-Capacity Toner Cartridge -Cyan (C)	A0V3 0GK
		High-Capacity Toner Cartridge - Black (K)	A0V3 01K
		High-Capacity Toner Cartridge - Yellow (Y)	A0V3 06K
		High-Capacity Toner Cartridge - Magenta (M)	A0V3 0CK
		High-Capacity Toner Cartridge - Cyan (C)	A0V3 0HK

Machine Type	Machine Part Number	Toner Cartridge Type	Toner Cartridge Part Number
GC	A0HF 082	Standard-Capacity Toner Cartridge -Yellow (Y)	A0V3 05N
		Standard-Capacity Toner Cartridge -Magenta (M)	A0V3 0AN
		Standard-Capacity Toner Cartridge -Cyan (C)	A0V3 0GN
		High-Capacity Toner Cartridge - Black (K)	A0V3 01N
		High-Capacity Toner Cartridge - Yellow (Y)	A0V3 06N
		High-Capacity Toner Cartridge - Magenta (M)	A0V3 0CN
		High-Capacity Toner Cartridge - Cyan (C)	A0V3 0HN



*For optimum print quality and performance, use only the corresponding TYPE genuine KONICA MINOLTA toner cartridges.*

Keep toner cartridges:

- In their packaging until you're ready to install them.
- In a cool, dry location away from sunlight (due to heat).
- The maximum storage temperature is 35°C (95°F) and the maximum storage humidity is 85% (noncondensing). If the toner cartridge is moved from a cold place to a warm, humid place, condensation may occur, degrading print quality. Allow the toner to adapt to the environment for about one hour before use.
- Level during handling and storage.

*Do not hold, stand or store cartridges on their ends or turn them upside down; the toner inside the cartridges may become caked or unequally distributed.*

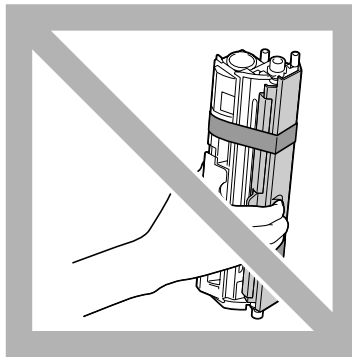

- Away from salty air and corrosive gases such as aerosols.

# Replacing a Toner Cartridge

## Note

**Be careful not to spill toner while replacing a toner cartridge. If toner spills, immediately wipe it off with a soft, dry cloth.**

If MACHINE SETTING/TONER OUT STOP in the UTILITY menu is set to ON or ON (FAX), the message TONER OUT/CHANGE X TONER (where "X" indicates the color of the toner) appears when the toner cartridge is nearly empty. Follow the steps below to replace the toner cartridge.

- 1 Check the message window to see which color toner cartridge needs replacing.



*If the machine detects that a toner cartridge is empty (TONER OUT or TONER LIFE END appears), the empty toner cartridge is automatically moved so that it can be replaced.*

*If this has occurred, skip steps 2 through 5, and continue with step 6.*

- 2 With the main screen displayed, press the ◀ key to display the PRINTER MODE screen.

- 3 Press the ▼ key to select T/C CHANGE and then press the **Select** key.

- 4 Press the **Select** key to select REPLACE MODE.

- 5 Press the ▲ or ▼ key to select the color for the toner cartridge to be replaced, and then press the **Select** key.

The toner cartridges rotate within the machine to move the toner cartridge of the selected color to a position where it can be replaced.



*To exit REPLACE MODE, press the **Stop/Reset** key.*

- 6 Open the front cover.



*Before opening the front cover, open Tray 1 if it is not already open.*

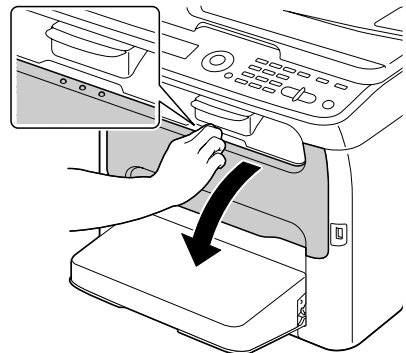



- 7 Check that the toner cartridge to be replaced has been moved to the front.



You can identify the toner cartridge by the color of the handle.

- 8 Pull down the handle on the toner cartridge until the toner cartridge is unlocked and moves out slightly toward you. Remove the toner cartridge.



*Do not manually rotate the toner cartridge carousel. In addition, do not rotate the carousel with force, otherwise it may be damaged.*

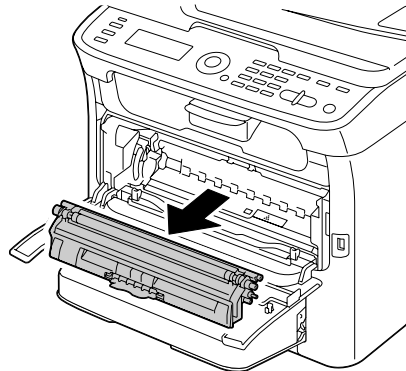
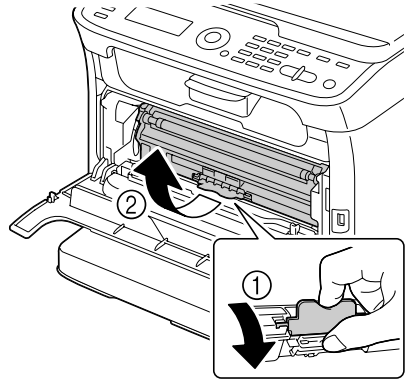

## Note

**Do not touch the contact indicated in the illustration.**

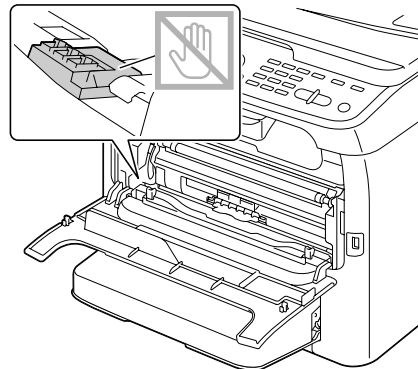

## Note

---

Dispose of the empty toner cartridge according to your local regulations. Do not burn the toner cartridge.  
For details, refer to “About Toner Cartridges” on page 7-2.

---

- 9 Check the color of the new toner cartridge to be installed.
- 10 Remove the toner cartridge from the bag.
- 11 Shake the cartridge a few times to distribute the toner.



*Make sure that the toner roller cover is securely attached before shaking the toner cartridge.*

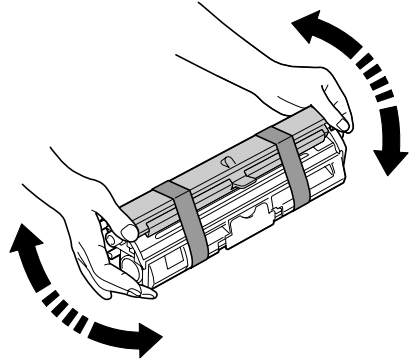

- 12 Remove the cover from the toner roller.



*Do not touch or scratch the toner roller.*

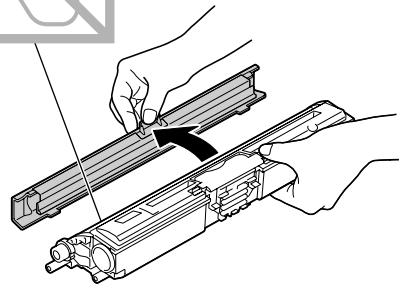

- 13** Align the shaft on each end of the toner cartridge with its holders, and then insert the cartridge.



*Before inserting the toner cartridge, make sure that the color of the toner cartridge to be installed is the same as the label on the toner cartridge carousel.*

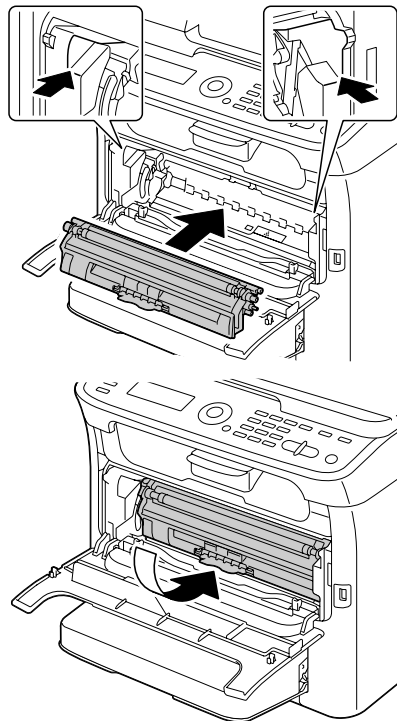

## Note

**Do not touch the contact indicated the illustration.**

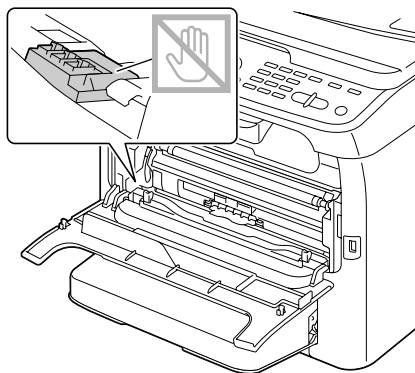

- 14 Press in the toner cartridge until it locks into place.

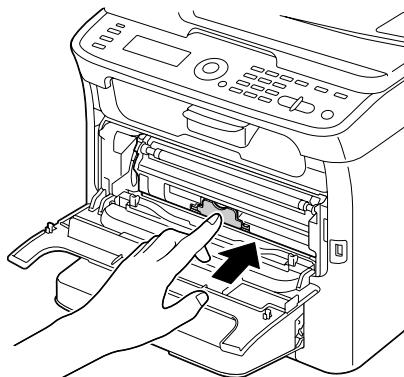

- 15 Close the front cover.

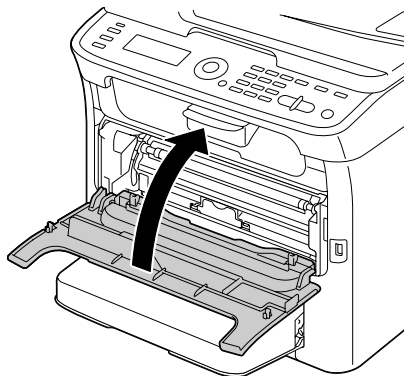

- 16 Press the **Stop/Reset** key to reset the machine and clear the indicator message.



*The machine must complete a calibration cycle (less than 2 minutes) after a toner cartridge has been replaced. If you open the scanner unit or front cover before the machine is reset, the calibration stops, then starts over again after the cover is closed.*

# Replacing All Toner Cartridges at the Same Time

## Note

---

**Be careful not to spill toner while replacing a toner cartridge. If toner spills, immediately wipe it off with a soft, dry cloth.**

---

By selecting the **EJECT MODE** in the **PRINTER MODE** menu, all toner cartridges can be replaced at the same time.

Follow the procedure described below to use the **EJECT MODE**.

- 1 With the main screen displayed, press the ◀ key to display the **PRINTER MODE** screen.
- 2 Press the ▼ key to select **T/C CHANGE** and then press the **Select** key.
- 3 Press the ▼ key to select **EJECT MODE** and then press the **Select** key.
- 4 Perform the operations described in steps 6 through 15 of “Replacing a Toner Cartridge” on page 7-5 through 7-9 to replace the magenta toner cartridge.



*To exit **EJECT MODE**, press the **Stop/Reset** key.*

- 5 Follow the same procedure to replace the cartridges for the cyan, black, then yellow toners.
- 6 Press the **Stop/Reset** key to reset the machine.



*The machine must complete a calibration cycle (less than 2 minutes) after a toner cartridge has been replaced. If you open the scanner unit or front cover before the machine is reset, the calibration stops, then starts over again after the cover is closed.*

## Replacing the Imaging Cartridge

When replacing an imaging cartridge, refer to the following table. For optimum print quality and performance, use only approved KONICA MINOLTA imaging cartridge for your specific machine type, as listed in the table below. You can find your machine type and the imaging cartridge part numbers on the consumables reorder label inside the ADF cover.

Machine Type	Machine Part Number	Part Name	Imaging Cartridge Part Number
AM	A0HF 012	Imaging Cartridge	A0VU 011
EU	A0HF 022		A0VU 0Y1
AP	A0HF 042		A0VU 0Y1
GC	A0HF 082		A0VU 0Y1



*For optimum print quality and performance, use only the corresponding TYPE genuine KONICA MINOLTA imaging cartridge.*



*You are advised to replace the imaging cartridge when the message I/C LIFE END/REPLACE I/C appears.*

- 1 Open the scanner unit.



*If there is paper in the output tray, remove it, and then fold up the output tray before opening the scanner unit.*

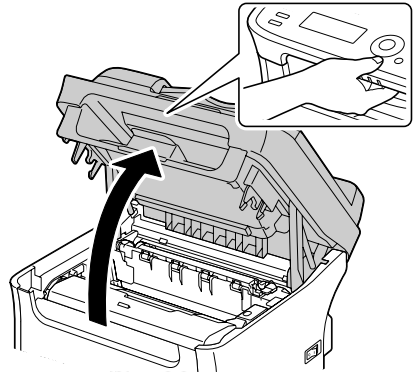

---

**Note**

Do not touch the wires and flat cable shown in the illustration.

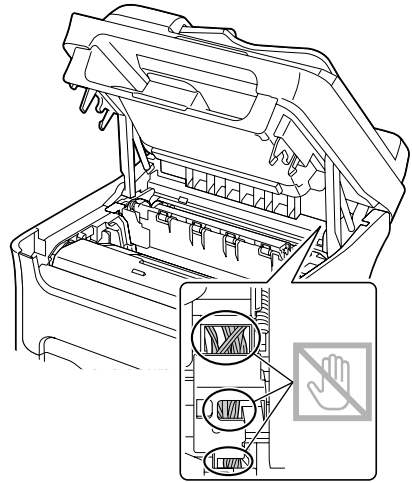

- 
- 2 Grab the handle and lift it up slightly to the back, and then slowly pull the imaging cartridge out vertically.

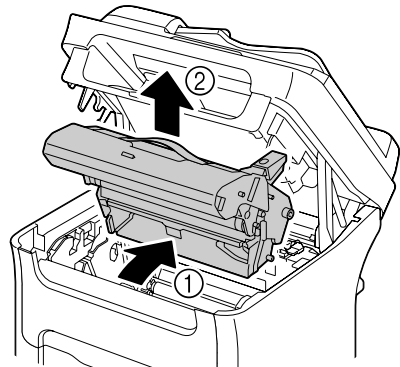

---

**Note**

Dispose of the used imaging cartridge according to your local regulations. Do not burn the imaging cartridge.

---

- 3 Prepare the new imaging cartridge.

**Note**

Do not touch the PC drum and the transfer belt on the imaging cartridge.

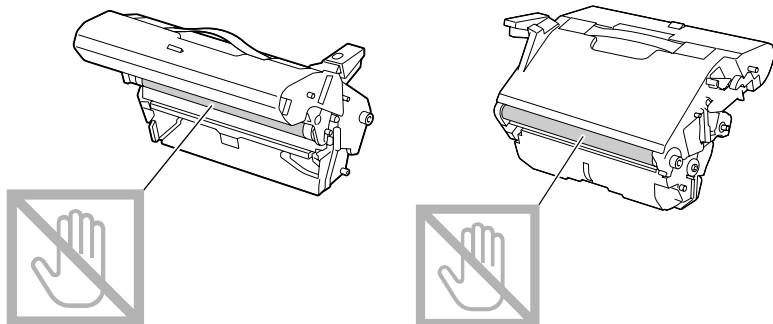

- 4 Slowly insert the new imaging cartridge vertically, and then push it slightly down toward you to finish installing the imaging cartridge.

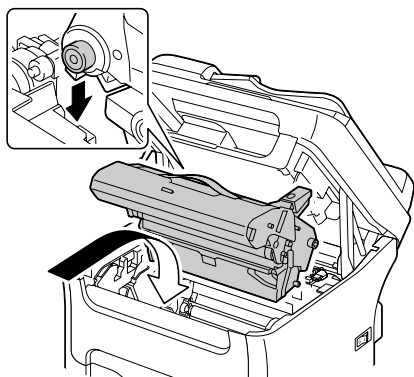

- 5 Carefully close the scanner unit.

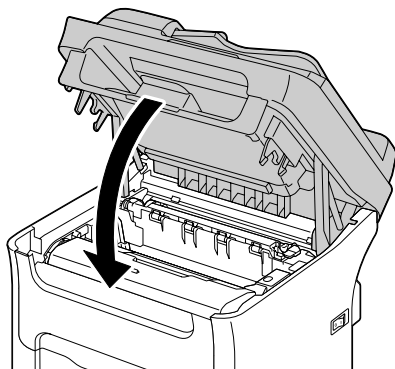



## Note

---

Do not touch the wires and flat cable shown in the illustration.

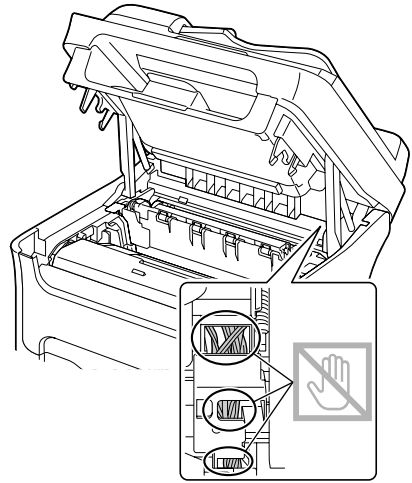

*The machine must complete a calibration cycle (less than 2 minutes) after the imaging cartridge has been replaced. If you open the scanner unit or front cover before the machine is reset, the calibration stops, then starts over again after the cover is closed.*

## Replacing the Fuser Unit

For optimum print quality and performance, use only approved KONICA MINOLTA fuser unit for your specific machine type.

- 1 Turn off the machine and disconnect the power cord.

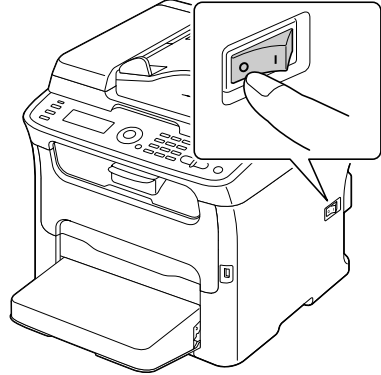

---

### Note

**There are extremely hot parts within the machine. Before replacing the fuser unit, wait about 20 minutes after turning off the machine, and then check that the fusing section has reached room temperature, otherwise, you may get burnt.**

---

- 2 Open the scanner unit.



*If there is paper in the output tray, remove it, and then fold up the output tray before opening the scanner unit.*

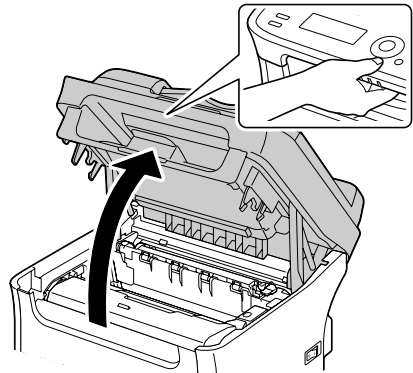

## Note

---

Do not touch the wires and flat cable shown in the illustration.

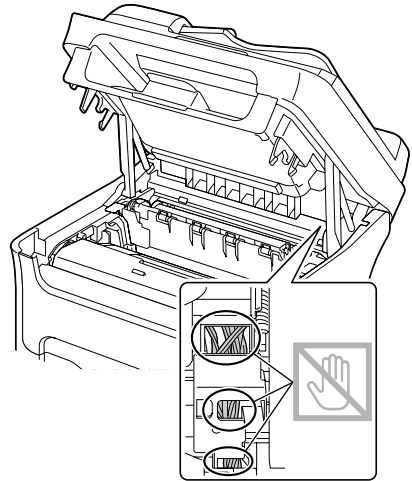

- 3** Push the blue handles back as far as possible.

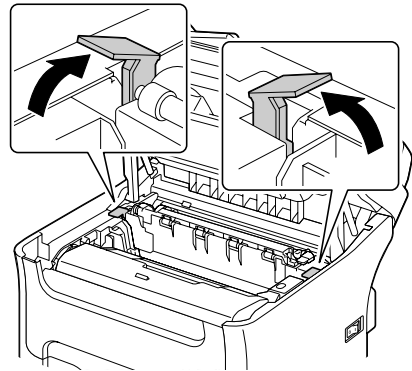

- 4 Grab the blue handles and lift the fuser unit to remove it.

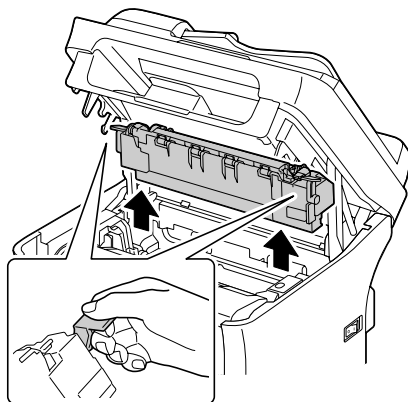

---

**Note**

**Do not touch the matching connectors of the fuser unit and the machine.**

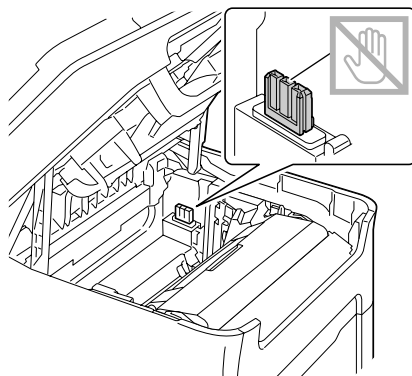

- 5 Prepare a new fuser unit.
- 6 Pull the fuser separator levers forward as far as possible.

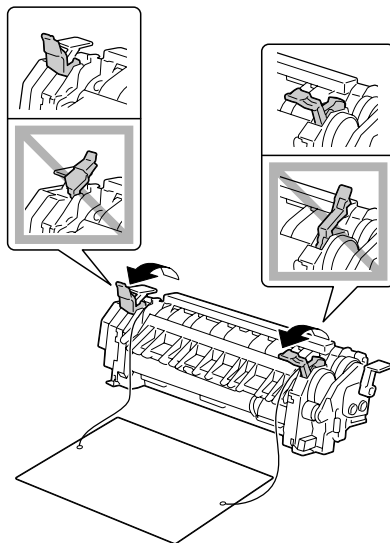

- 7 Remove the fuser separator material, and then return the fuser separator levers to their original positions.

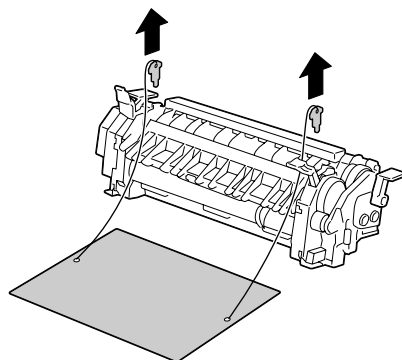

## Note

---

Be careful not to touch the paper exit sensor and the surface of the fuser roller in the fuser unit.

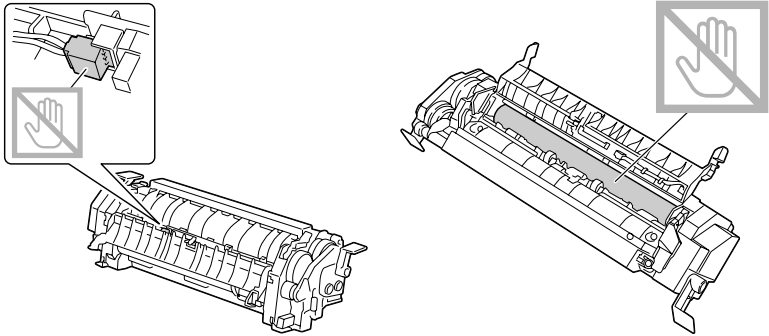

- 8 While lifting the fuser unit with the blue handles (one on each side), vertically insert the fuser unit.

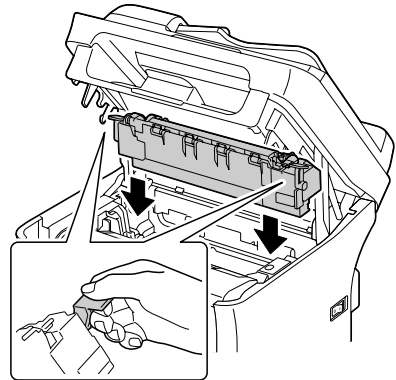

---

**Note**

---

Do not touch the paper exit sensor on the fuser unit.

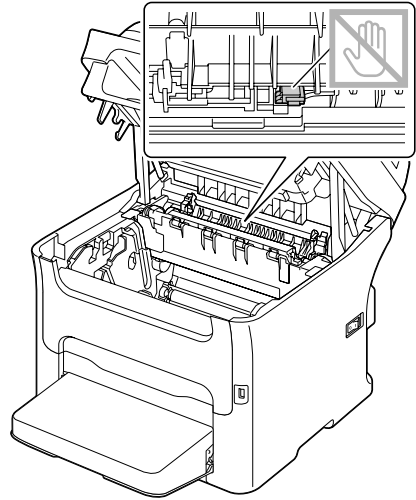

---

**Note**

---

Do not touch the matching connectors of the fuser unit and the machine.

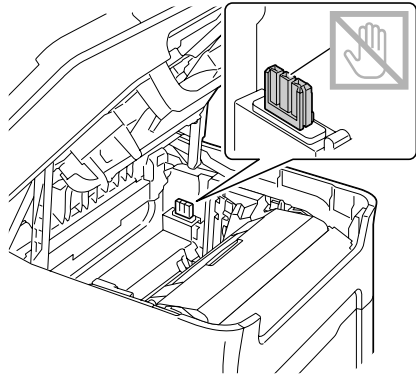

- 9 After the fuser unit is firmly installed, flip the blue handles down toward you.

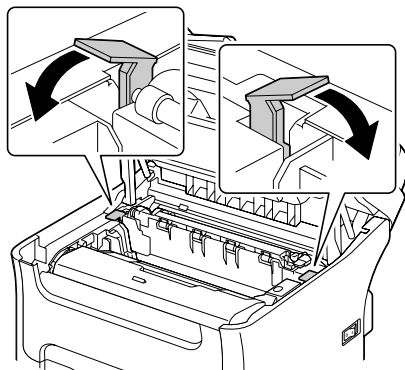

- 10 Carefully close the scanner unit.

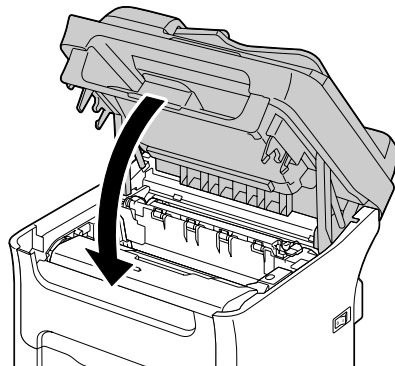

---

### Note

Do not touch the wires and flat cable shown in the illustration.

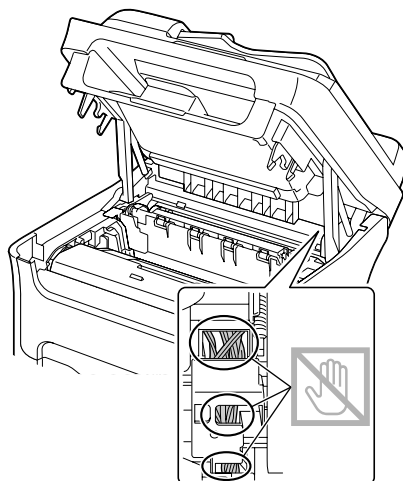



- 11 Reconnect the power cord, and turn on the machine.

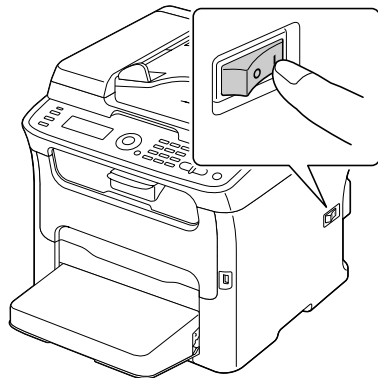

***Maintenance*** **8**



# Maintaining the Machine



## CAUTION

**Read all caution and warning labels carefully, making sure to follow any instructions contained in them. These labels are located on the inside of the machine's covers and the interior of the machine body.**

Handle the machine with care to preserve its life. Abuse handling may cause damage and void your warranty. If dust and paper scraps remain on the inside or outside of the machine, machine performance and print quality will suffer, so the machine should be cleaned periodically. Keep the following guidelines in mind.



## WARNING!

**Turn off the machine, unplug the power cord, and disconnect all interface cables before cleaning. Do not spill water or detergent into the machine; otherwise the machine will be damaged and an electric shock may occur.**



## CAUTION

**The fuser unit is hot. When the top door is opened, the fuser unit temperature drops gradually (one hour wait time).**



- Be careful when cleaning the inside of the machine or removing media misfeeds, as the fuser unit and other internal parts may be very hot.
- Do not place anything on top of the machine.
- Use a soft cloth to clean the machine.
- Never spray cleaning solutions directly on the machine's surface; the spray could penetrate through the air vents of the machine and damage the internal circuits.
- Avoid using abrasive or corrosive solutions or solutions that contain solvents (such as alcohol and benzene) to clean the machine.
- Always test any cleaning solution (such as mild detergent) on a small inconspicuous area of your machine to check the solution's performance.
- Never use sharp or rough implements, such as wire or plastic cleaning pads.
- Always close the machine's covers gently. Never subject the machine to vibration.

- Do not cover the machine immediately after using it. Turn it off and wait until it cools down.
- Do not leave the machine's covers open for any length of time, especially in well-lit places; light may damage the toner cartridges.
- Do not open the machine during printing.
- Do not tap media stacks on the machine.
- Do not lubricate or disassemble the machine.
- Do not tilt the machine.
- Do not touch the electrical contacts, gears, or laser devices. Doing so may damage the machine and cause the print quality to deteriorate.
- Keep media in the output tray at a minimum level. If the media is stocked too high, your machine may experience media misfeeds and excessive media curl.
- When lifting the machine, grasp the areas shown in the figure. Keep the machine level to avoid toner spillage.
- Before moving the machine, remove the dust cover, and fold up Tray 1.
- If the optional lower feeder unit, attachment and duplex option are installed, remove them and move them separately.
- If you get toner on your skin, wash it off with cool water and a mild soap.

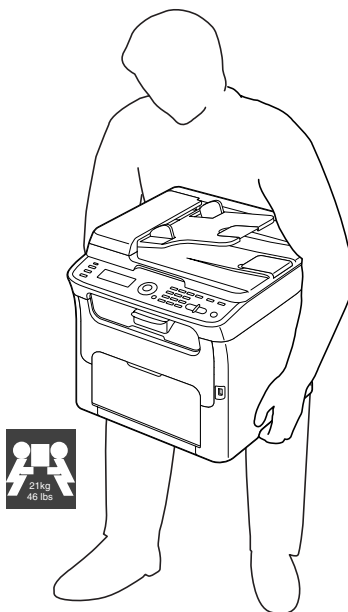

## CAUTION

**If you get toner in your eyes, wash it out immediately with cool water and consult a doctor.**

- Make sure any parts removed during cleaning are replaced before you plug in the machine.

# Cleaning the Machine



## CAUTION

Be sure to turn off the machine and unplug the power cord before cleaning. However, be sure to turn on the machine when cleaning the print head window.

### Exterior

#### ■ Control Panel

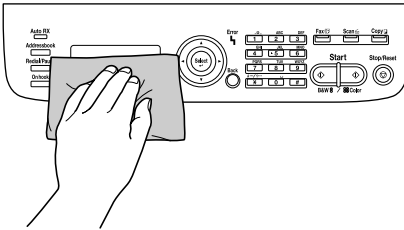

#### ■ Ventilation Grill

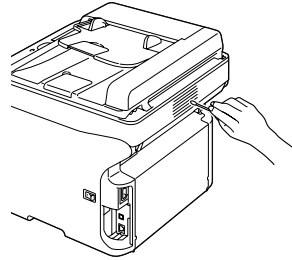

#### ■ Machine Exterior

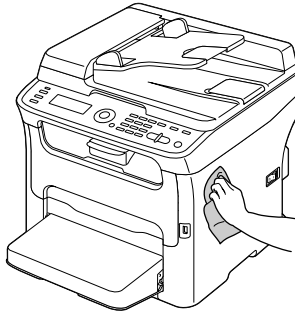

#### ■ Original Glass

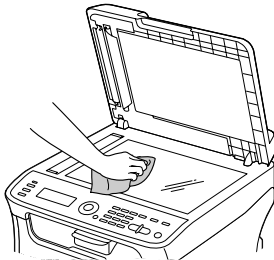

#### ■ Original Cover Pad

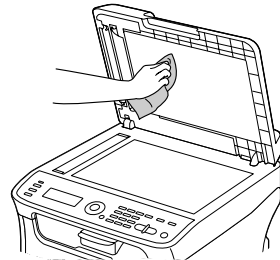

## Media Rollers

The accumulation of paper dust and other debris on the media rollers can cause media-feeding problems.

### Cleaning the Media Feed Roller

- 1 Open the scanner unit.

 *If there is paper in the output tray, remove it, and then fold up the output tray before opening the scanner unit.*

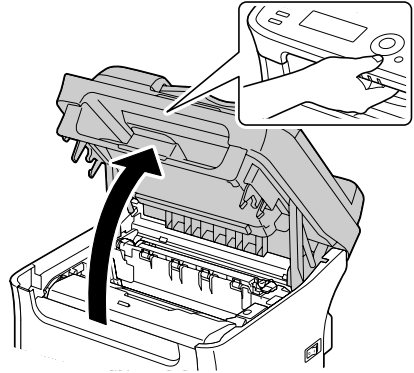

---

### Note

**Do not touch the wires and flat cable shown in the illustration.**

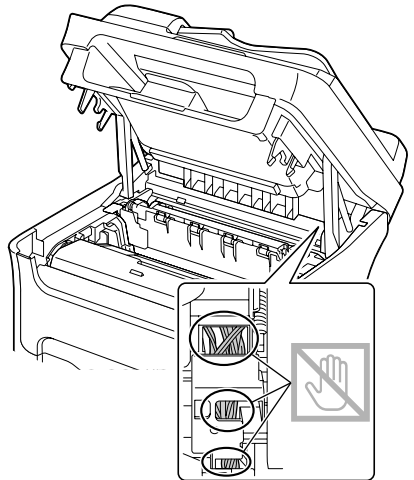

- 2 Grab the handle and lift it up slightly to the back, and then slowly pull the imaging cartridge out vertically.

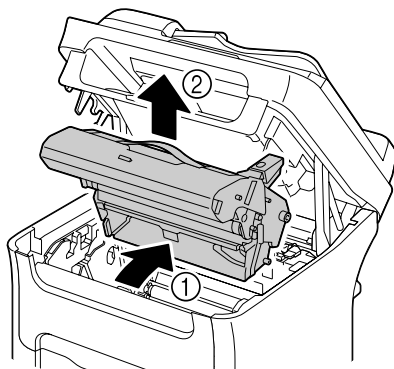

---

### Note

Do not touch the PC drum and the transfer belt on the imaging cartridge.

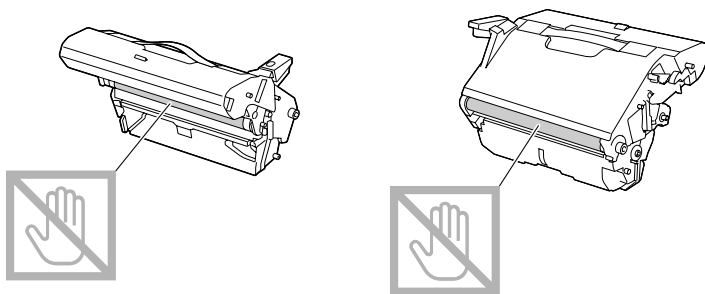

Position the removed imaging cartridge horizontally as shown in the illustration at the right. Be sure to keep the imaging cartridge horizontal and place it where it will not become dirty. Do not leave the imaging cartridge removed for more than 15 minutes, and do not place the removed imaging cartridge in a location where it would be exposed to direct light (such as sunlight).

---

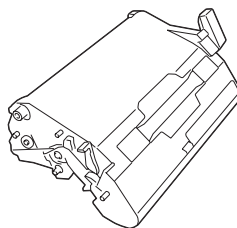

- 3** Clean the media feed rollers by wiping them with a soft, dry cloth.

BOTTOM  
VIEW

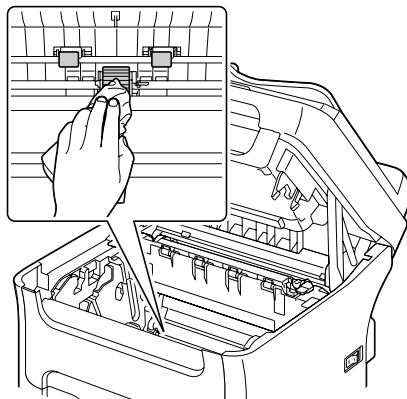

## CAUTION

The area around the fuser unit is extremely hot. Touching anything other than the indicated levers may result in burns. If you get burned, immediately cool the skin under cold water, and then seek professional medical attention.

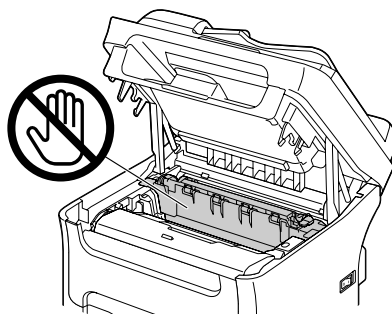



## Note

---

Decreased print quality may result if the surface of the transfer roller is touched. Be careful not to touch the surface of the transfer roller.

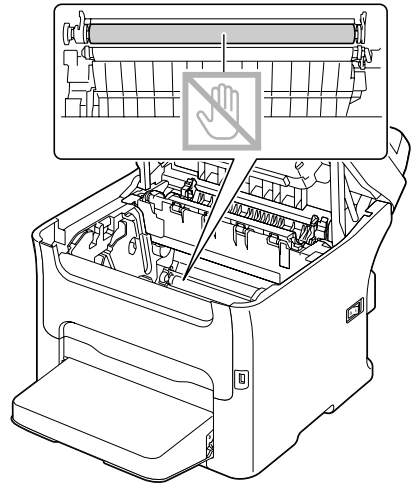

- 
- 4 Slowly insert the imaging cartridge vertically, and then push it slightly down toward you to finish reinstalling the imaging cartridge.

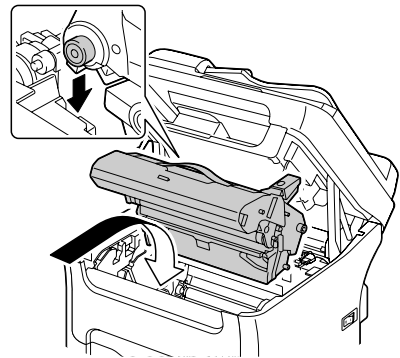

**5** Carefully close the scanner unit.

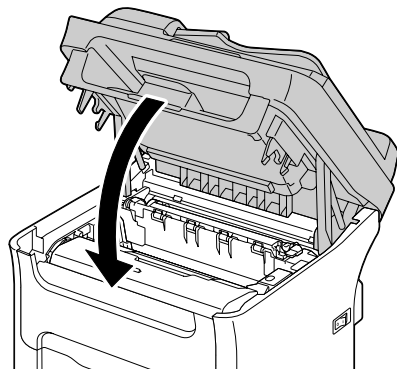

---

**Note**

Do not touch the wires and flat cable shown in the illustration.

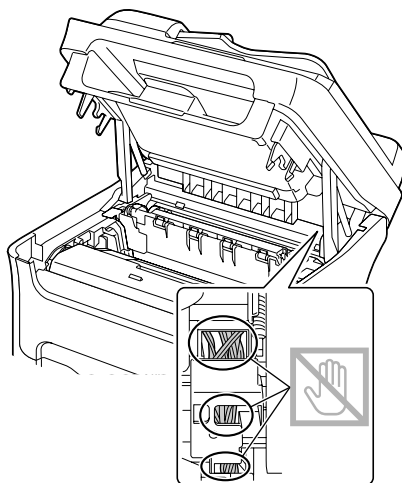

## Cleaning the Media Feed Rollers for the ADF

- 1 Open the ADF feed cover.

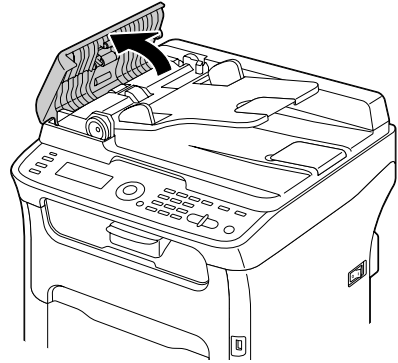

- 2 Clean the media feed rollers by wiping them with a soft, dry cloth.

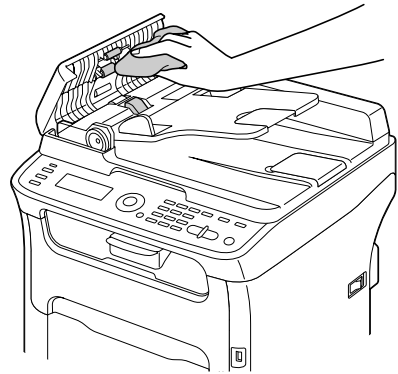

- 3 Close the ADF feed cover.

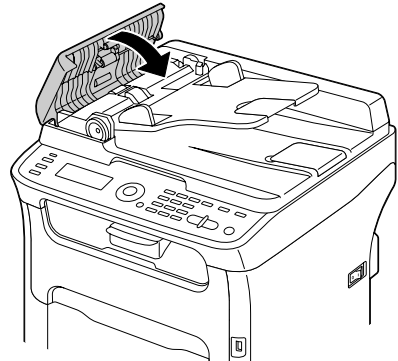

## Cleaning the Media Feed Rollers for Tray 2

Be sure to remove the duplex option before cleaning the media feed rollers for Tray 2.

- 1 If the duplex option is installed, remove it.



*If the duplex option is not installed and the locking pins are installed at the back of Tray 2, remove the locking pins (one in each opening on the left and right sides at the back of Tray 2). To remove a locking pin, turn it to either the left or the right so that its grip is vertical, and then pull out the locking pin to remove it.*

- 2 Remove the dust cover from Tray 1 and close the tray.
- 3 Lift the machine off of Tray 2 and temporarily place it on a sturdy flat surface.

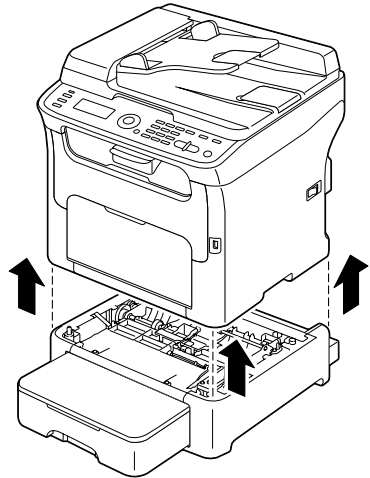

- 4 Clean the media feed rollers by wiping them with a soft, dry cloth.

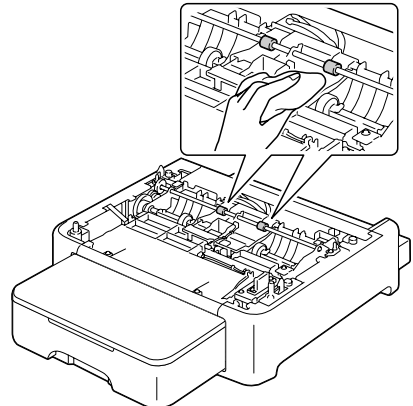

- 5** Lift the machine and reinstall it on top of Tray 2.

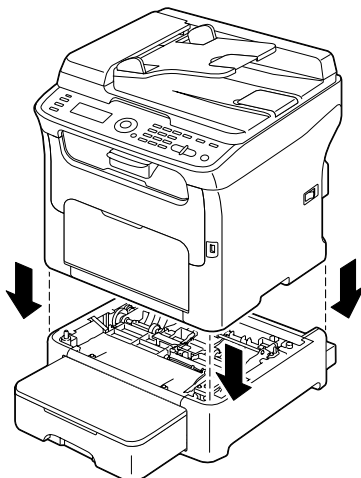

- 6** Open Tray 1 and reattach the dust cover.

- 7** If you removed the duplex option in step 1, reinstall it.



*If the duplex option is not to be installed, install the locking pins. While holding the grip of the locking pin vertical, insert the locking pin into the opening on either the left or right side of the lower feeder unit and, while pushing it in, turn it to either the left or the right. The locking pin is installed when its grip is horizontal. Installing the left and right locking pins secures the lower feeder unit to the machine so it cannot be removed.*

## Cleaning the Media Feed Rollers for the attachment

Be sure to remove the duplex option before cleaning the media feed rollers for the attachment.

- 1 If the duplex option is installed, remove it.
- 2 Remove the dust cover from Tray 1 and close the tray.
- 3 Lift the machine off of the attachment and temporarily place it on a sturdy flat surface.

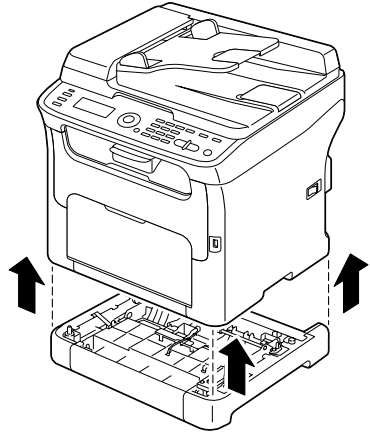

- 4 Clean the media feed rollers by wiping them with a soft, dry cloth.

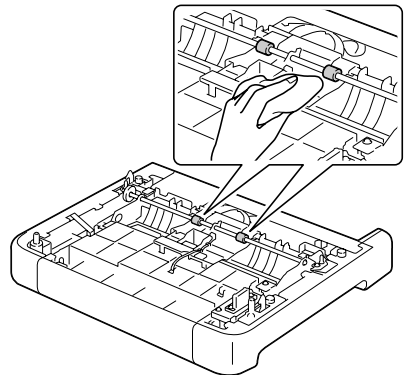

- 5** Lift the machine and reinstall it on top of the attachment.

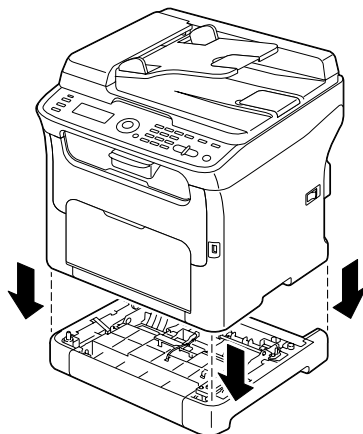

- 6** Open Tray 1 and reattach the dust cover.

- 7** If you removed the duplex option in step 1, reinstall it.

## Cleaning the Media Feed Rollers for the Duplex

- 1 Open the duplex door.

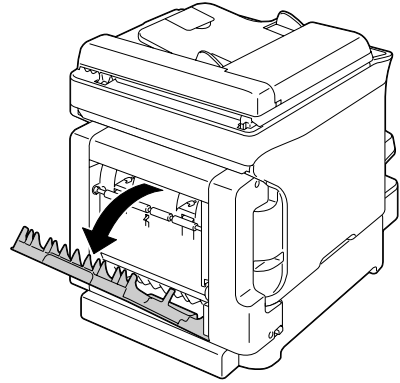

- 2 Clean the feed rollers by wiping them with a soft, dry cloth.

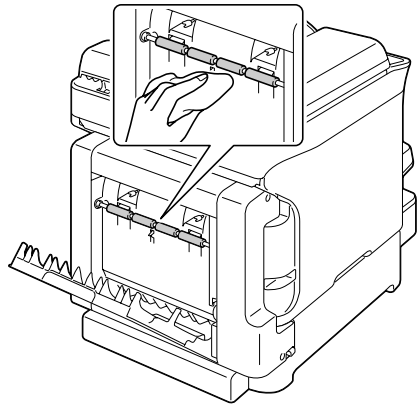

- 3 Close the duplex door.

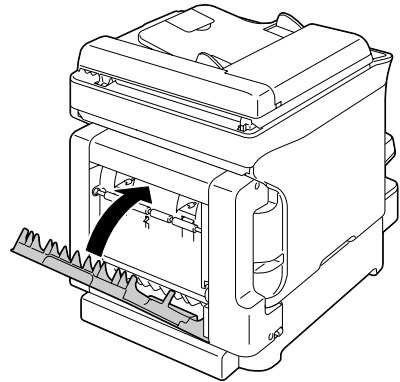



## Print Head Window

Continuing to use this machine with a dirty print head window can cause print quality problems.

### Clearing the Print Head Window

- 1 With the main screen displayed, press the ◀ key to display the **PRINTER MODE** screen.
- 2 Press the ▼ key to select **T/C CHANGE** and then press the **Select** key.
- 3 Press the ▼ key to select **P/H CLEAN MODE** and then press the **Select** key.



*It is not possible to exit P/H CLEAN MODE before the operation is finished (even if the **Stop/Reset** key is pressed).  
If the machine has incorrectly been switched to P/H CLEAN MODE, perform steps 4 through 7, then steps 11 through 16 (skipping steps 8 through 10) to exit P/H CLEAN MODE mode.*

- 4 Open the front cover.



*Before opening the front cover, open Tray 1 if it is not already open.*

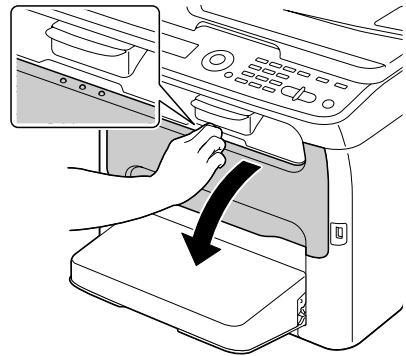

- 5** The magenta toner cartridge has been moved to the position from where it can be replaced. Pull down the handle on the toner cartridge until the toner cartridge is unlocked and moves out slightly toward you. Remove the toner cartridge.



*When the magenta toner cartridge is removed, a gap is created within the machine so that the print head window can easily be cleaned.*

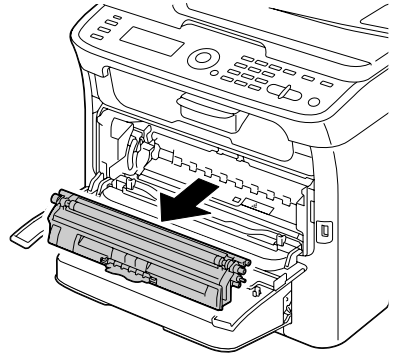
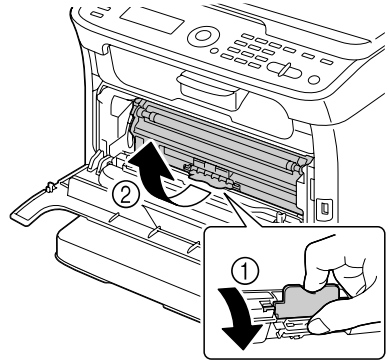

## Note

**Do not touch the contact indicated the illustration.**

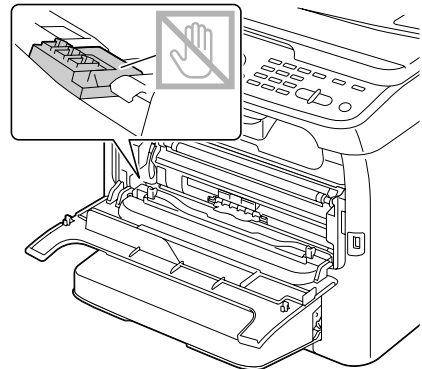

**6** Close the front cover.



*The toner cartridge rotate within the machine.*

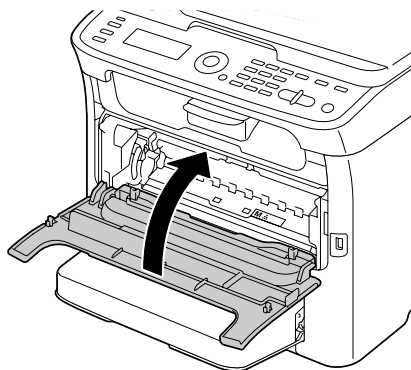

**7** After the toner cartridges have finished rotating, open the scanner unit.

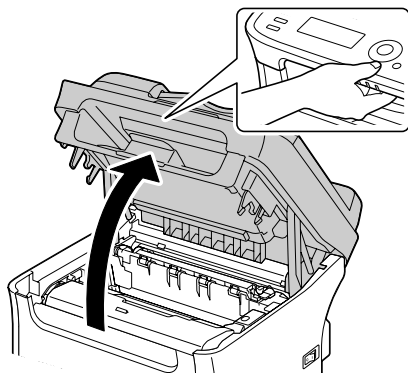

---

### **Note**

**Do not touch the wires and flat cable shown in the illustration.**

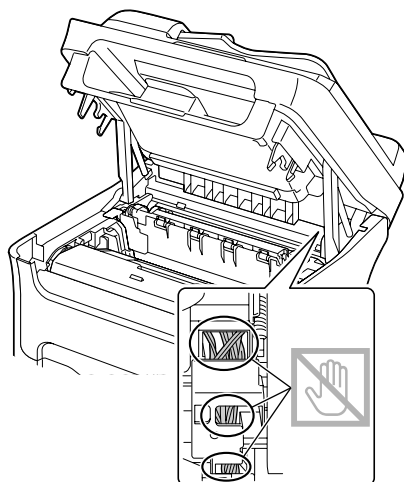

- 8** Grab the handle and lift it up slightly to the back, and then slowly pull the imaging cartridge out vertically.

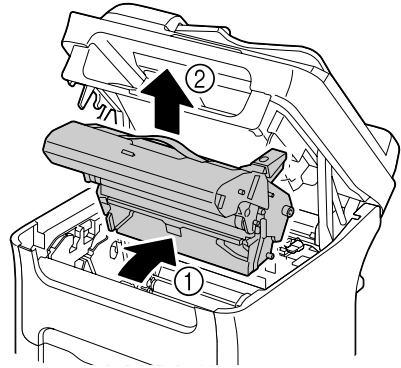

---

**Note**

Do not touch the PC drum and the transfer belt on the imaging cartridge.

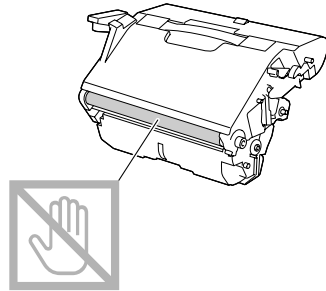
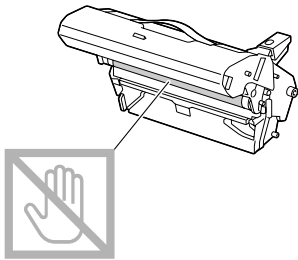

Position the removed imaging cartridge horizontally as shown in the illustration at the right. Be sure to keep the imaging cartridge horizontal and place it where it will not become dirty. Do not leave the imaging cartridge removed for more than 15 minutes, and do not place the removed imaging cartridge in a location where it would be exposed to direct light (such as sunlight).

---

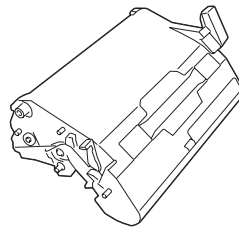

- 9 Clean the print head window by wiping it with a soft, dry cloth.

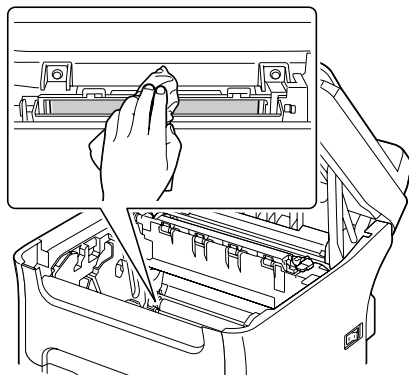

## CAUTION

The area around the fuser unit is extremely hot. Touching anything other than the indicated levers may result in burns. If you get burned, immediately cool the skin under cold water, and then seek professional medical attention.

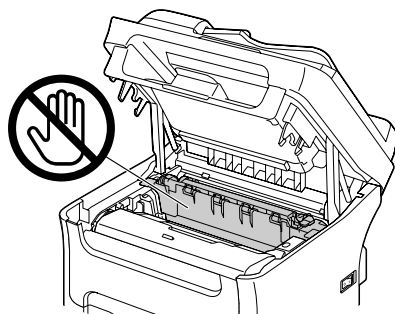

## Note

---

Decreased print quality may result if the surface of the transfer roller is touched. Be careful not to touch the surface of the transfer roller.

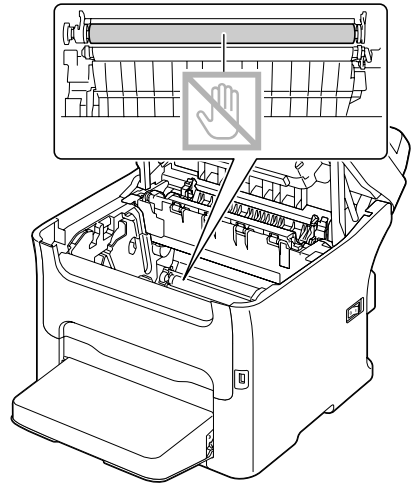

- 
- 10 Slowly insert the imaging cartridge vertically, and then push it slightly down toward you to finish reinstalling the imaging cartridge.

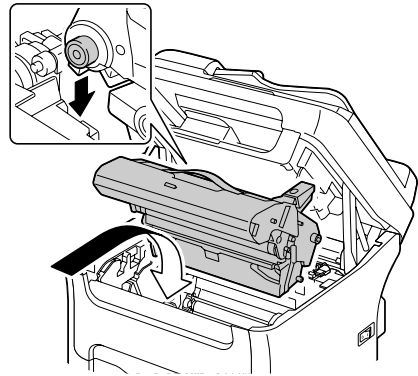

11 Close the scanner unit.

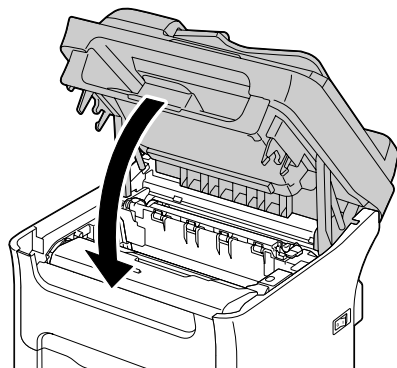

---

**Note**

Do not touch the wires and flat cable shown in the illustration.

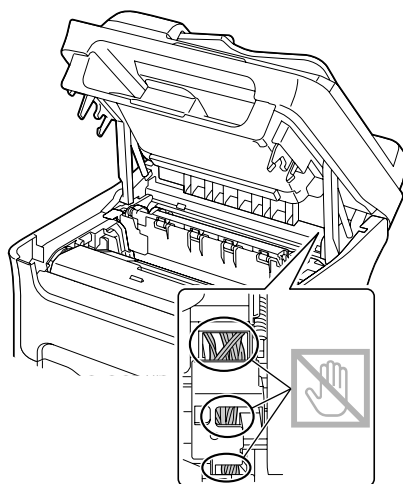

---

12 Press the **Stop/Reset** key.

- 13** After the toner cartridges have finished rotating, open the front cover.

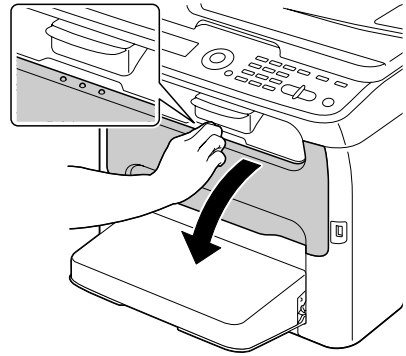

- 14** Align the shaft on each end of the toner cartridge with its holders, and then insert the cartridge.

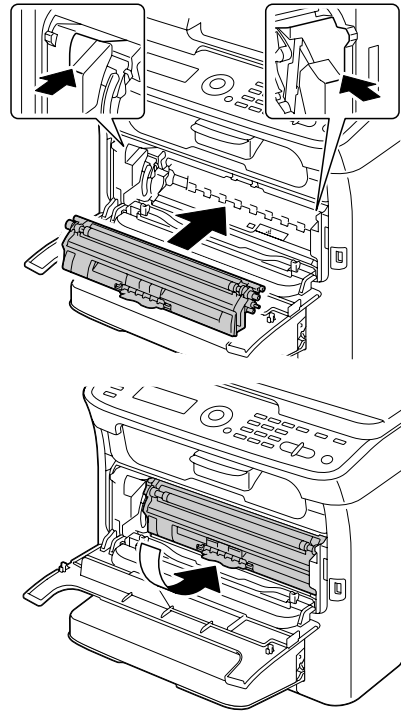



## Note

Do not touch the contact indicated the illustration.

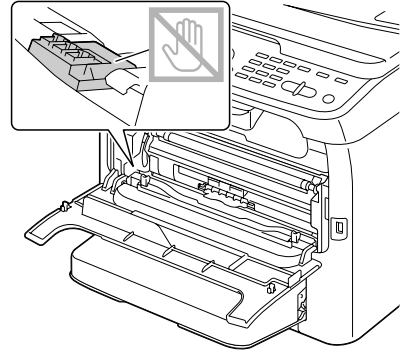

- 15 Press in the magenta toner cartridge until it locks into place.

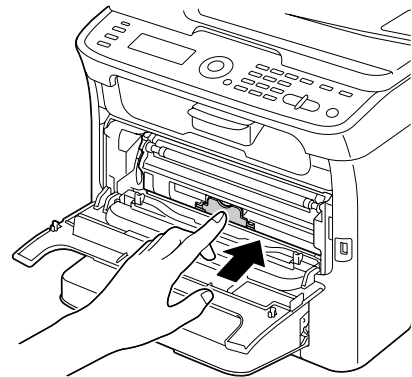

- 16 Close the front cover.

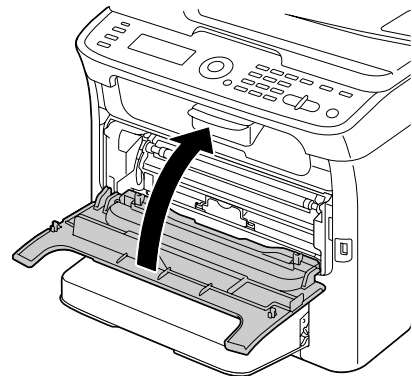

# *Troubleshooting* 9



# Introduction

This chapter provides information to aid you in resolving machine problems you may encounter, or at least guide you to the proper sources for help.

Printing a Configuration Page	page 9-3
Preventing Media Misfeeds	page 9-4
Understanding the Media Path	page 9-5
Clearing Media Misfeeds	page 9-5
Solving Problems with Media Misfeeds	page 9-23
Solving Other Problems	page 9-26
Solving Problems with Printing Quality	page 9-31
Status, Error, and Service Messages	page 9-37

# Printing a Configuration Page

- 1 In the main screen, press the ▲ or ▼ key to select REPORT/STATUS, and then press the **Select** key.
- 2 Press the ▲ or ▼ key to select REPORT, and then press the **Select** key.
- 3 Press the ▲ or ▼ key to select CONFIGURATION PAGE, and then press the **Select** key.
- 4 Press the **Start-B&W** key or the **Start-Color** key.

# Preventing Media Misfeeds

<b>Make sure that...</b>
Media matches the machine specifications.
Media is flat, especially on the leading edge.
The machine is on a hard, flat, level surface.
You store media in a dry location away from moisture and humidity.
You always adjust the media guides in Tray 1 after inserting the media (a guide that is not properly adjusted can cause poor print quality, media misfeeds, and machine damage).
You load the media printing-side up in the tray ( <i>many manufacturers place an arrow on the end of the wrapper to indicate the printing side</i> ).

<b>Avoid...</b>
Media that is folded, wrinkled, or excessively curled.
Double feeding ( <i>remove the media and fan the sheets—they may be sticking together</i> ).
Loading more than one type/size/weight of media in a tray at the same time.
Overfilling the trays.
Allowing the output tray to overfill ( <i>the output tray has a 100 sheet capacity—misfeeding may occur if you allow more than 100 sheets of media to accumulate at one time</i> ).

# Understanding the Media Path

Understanding the media path will help you locate media misfeeds.

1. ADF media feed rollers
2. Document feed tray
3. Document output tray
4. Output tray
5. Imaging cartridge
6. Toner cartridge carousel
7. Tray 1 (multipurpose tray)
8. Tray 2 (optional lower feed unit)
9. Fuser unit
10. Duplex (optional)

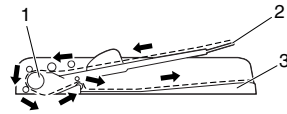

Document path

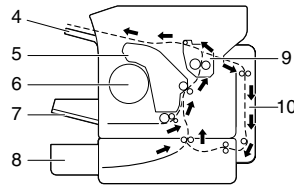

Media path

## Clearing Media Misfeeds

To avoid damage, always remove misfed media gently, without tearing it. Any piece of media left in the machine, whether large or small, can obstruct the media path and cause further misfeeds. Do not reload media that has misfed.

### Note

---

**The image is not fixed on the media before the fusing process. If you touch the printed surface, the toner may stick to your hands, so be careful not to touch the printed face when removing the misfed media. Make sure not to spill any toner inside the machine.**

---



## **CAUTION**

Unfused toner can mess your hands, clothes, or anything else it gets on.

If you accidentally get toner on your clothes, lightly dust them off as best as you can. If some toner remains on your clothes, use cool, not hot water, to rinse the toner off. If toner gets on your skin, wash it off with cool water and a mild soap.

---

---



## **CAUTION**

If you get toner in your eyes, wash it out immediately with cool water and consult a doctor.

---

---

If, after clearing the media misfeed, the misfeed message in the message window persists, open and close the scanner unit. This should clear the misfeed message.

## Media Misfeed Messages and Clearing Procedures

Media Misfeed Message	Page Reference
CHECK TRAY1 PAPER LOAD PAPER ( <sup>1</sup> xx) (PRESS START KEY)	This message appears in the following cases. <ul style="list-style-type: none"> <li>● When no media is loaded in Tray 1</li> <li>● When a misfeed has occurred in Tray 1</li> </ul> <p>With the first case, load media into the tray, and then press the <b>Start</b> key. With the second case, refer to page 9-15.</p>
FUSER JAM OPEN TOP COVER	page 9-8
ORIGINAL DOC. JAM OPEN DOC.FEED COVER	page 9-19
OUTPUT JAM OPEN TOP COVER	page 9-8
TRANSFER JAM OPEN TOP COVER	page 9-8
TRAY2 JAM OPEN TOP COVER	page 9-16
DUPLEX JAM OPEN DUPLEX COVER	page 9-21
DUPLEX JAM OPEN TOP/DUPLEX	page 9-8 and page 9-21



## Clearing a Media Misfeed in the Machine

- 1 Open the scanner unit.



*If there is paper in the output tray, remove it, and then fold up the output tray before opening the scanner unit.*

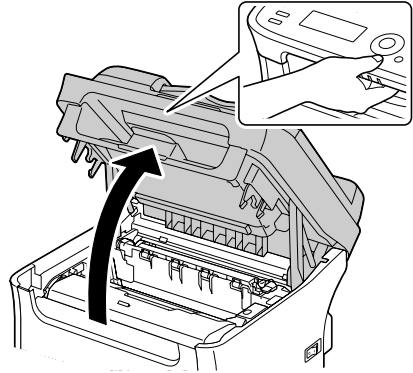

---

### Note

**Do not touch the wires and flat cable shown in the illustration.**

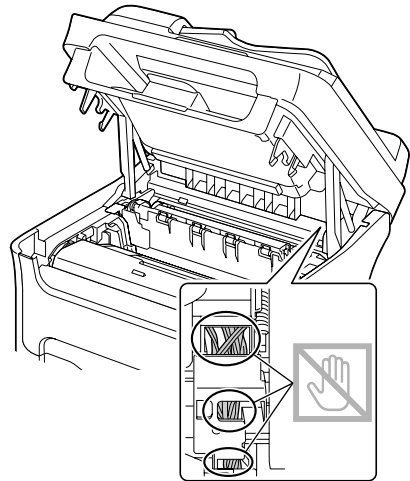

- 2 Grab the handle and lift it up slightly to the back, and then slowly pull the imaging cartridge out vertically.

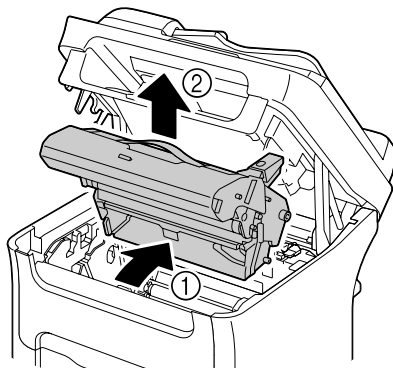

---

### Note

Do not touch the PC drum and the transfer belt on the imaging cartridge.

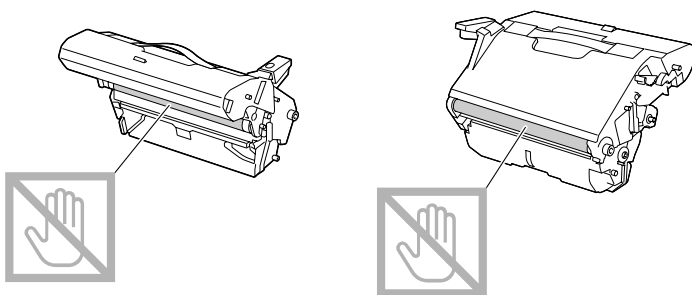

Position the removed imaging cartridge horizontally as shown in the illustration at the right. Be sure to keep the imaging cartridge horizontal and place it where it will not become dirty. Do not leave the imaging cartridge removed for more than 15 minutes, and do not place the removed imaging cartridge in a location where it would be exposed to direct light (such as sunlight).

---

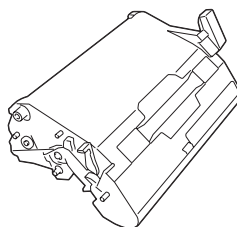

- 3 Push the fuser separator levers back as far as possible.

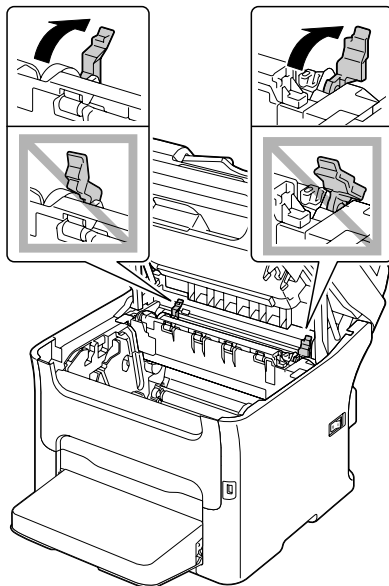

## CAUTION

The area around the fuser unit is extremely hot. Touching anything other than the indicated levers may result in burns. If you get burned, immediately cool the skin under cold water, and then seek professional medical attention.

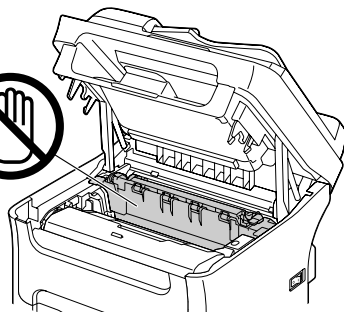

#### 4 Remove any misfed media.



*If a media misfeed occurs near the fuser unit, pull out the media from below the fuser unit, as shown in the illustration at the right.*

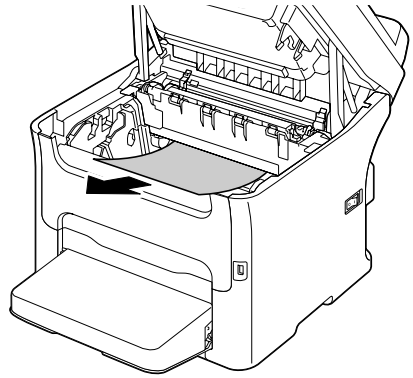

*If the media cannot be removed from below the fuser unit, raise the fuser unit cover, and then remove the media from above the fuser unit.*

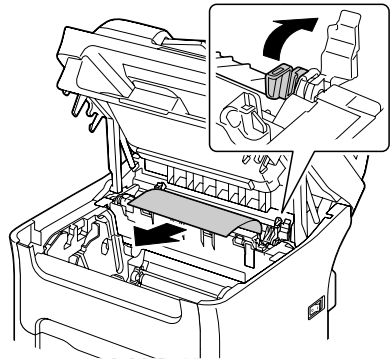

*Remove the dust cover from Tray 1 and remove the media.*

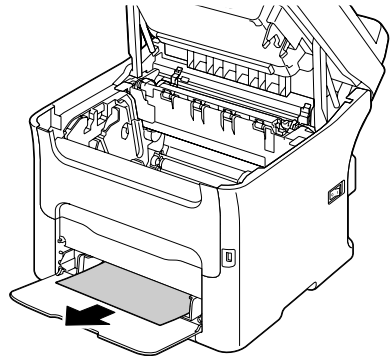

---

**Note**

---

Do not touch the surface of the fuser roller in the fuser unit.

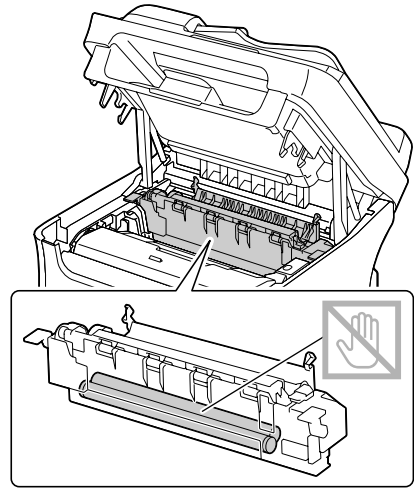

---

**Note**

---

Do not touch the paper exit sensor on the fuser unit.

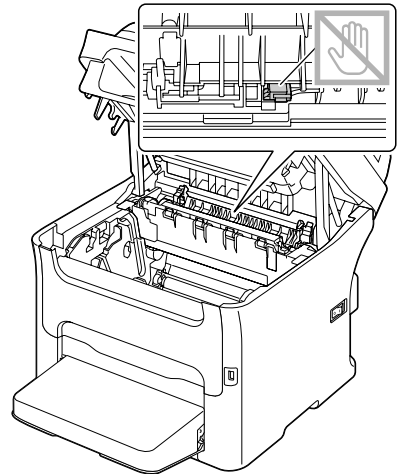

## Note

---

Decreased print quality may result if the surface of the transfer roller is touched. Be careful not to touch the surface of the transfer roller.

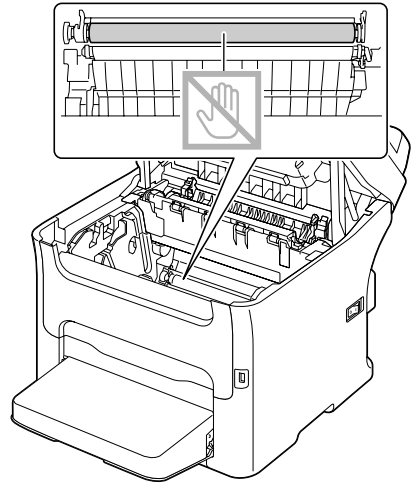

- 
- 5 Return the fuser separator levers to their original positions.

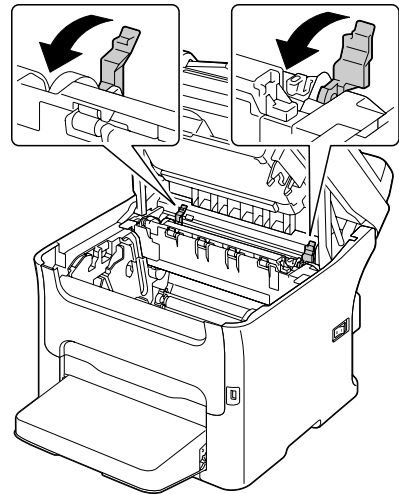

- 6 Slowly insert the imaging cartridge vertically, and then push it slightly down toward you to finish reinstalling the imaging cartridge.

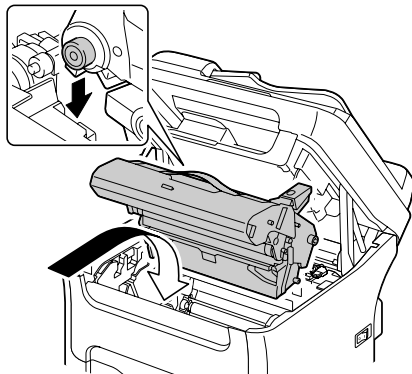

- 7 Carefully close the scanner unit.

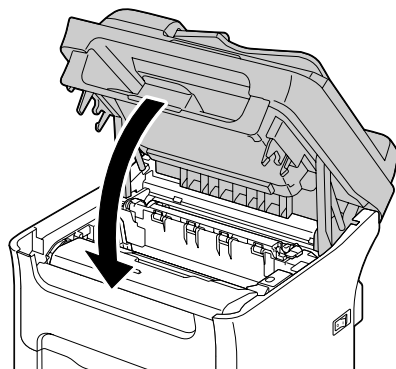

---

### Note

Do not touch the wires and flat cable shown in the illustration.

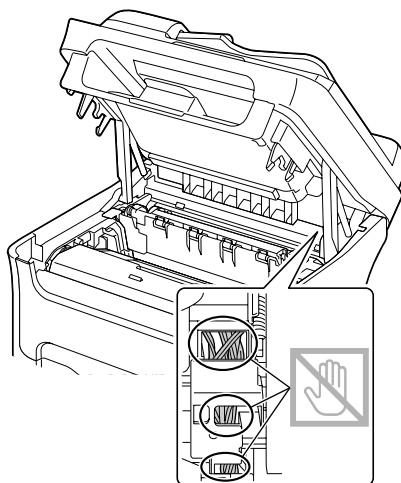

## Clearing a Media Misfeed From Tray 1

- 1 Remove the dust cover from Tray 1.

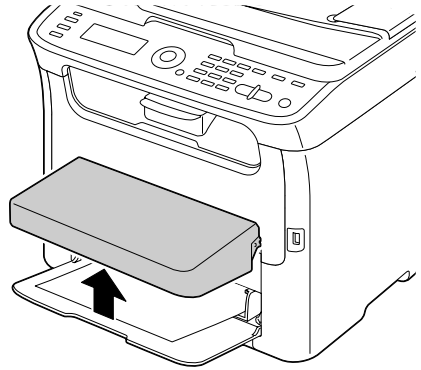

- 2 Carefully pull out the misfed media.



*If the media cannot be removed, instead of pulling it with extreme force, clear the media misfeed according to the procedure described in "Clearing a Media Misfeed in the Machine" on page 9-8.*

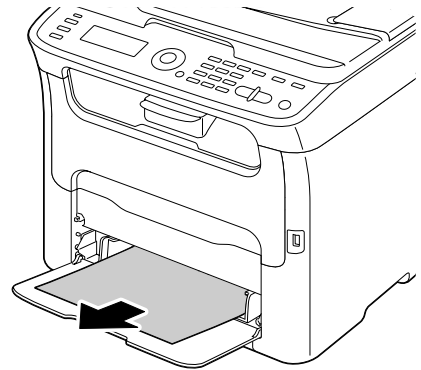

- 3 Reattach the dust cover.

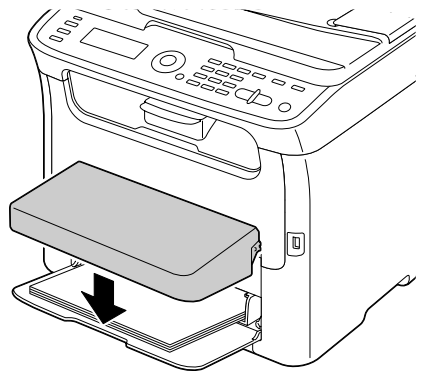

- 4 Press the **Start** key.



## Clearing a Media Misfeed in Tray 2

- 1 Pull out Tray 2 as far as possible.

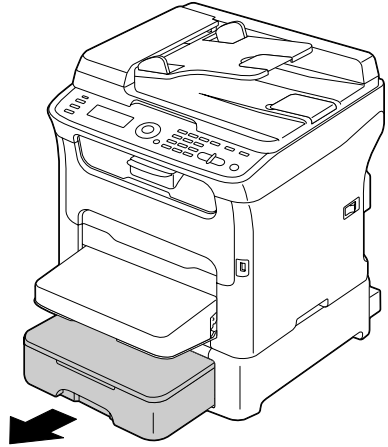

- 2 Lift up Tray 2 to remove it.

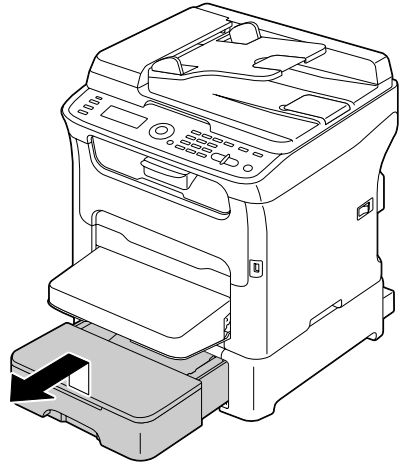

- 3 Remove any misfed paper.



*If necessary, remove the dust cover from Tray 1 and close the tray.*

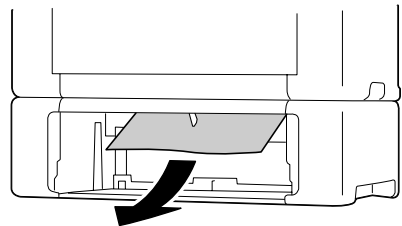

- 4** Remove the lid from Tray 2, and then remove all paper from the tray.

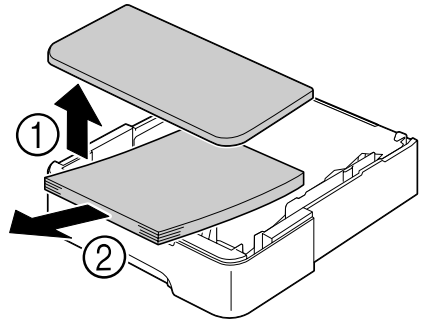

- 5** Fan the paper, and align its edges.

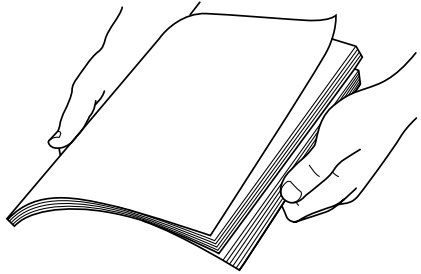

- 6** Press down the media pressure plate to lock it into place.

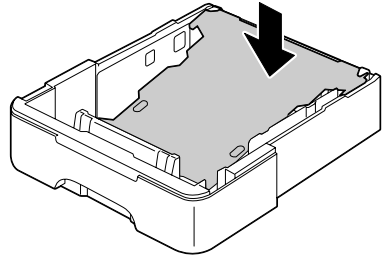

- 7** Load the media in Tray 2, and attach the lid.

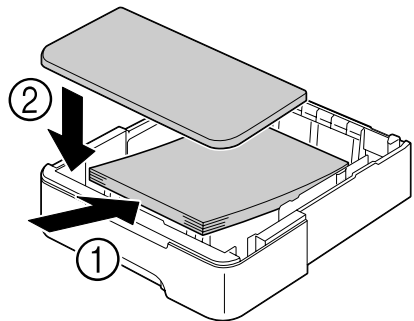

**8** Reinsert Tray 2.

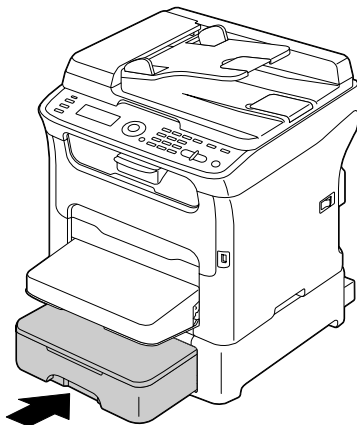

**9** Open and close the scanner unit to clear the misfeed message.

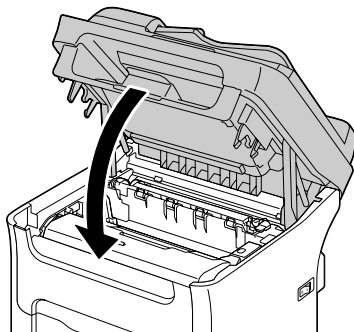
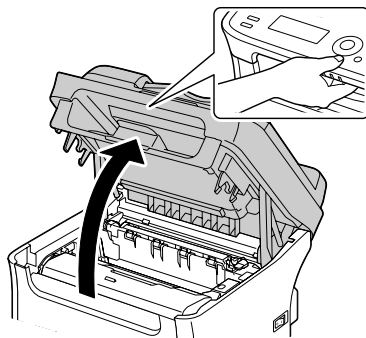

## Clearing a Media Misfeed from the ADF

- 1 Open the ADF feed cover.

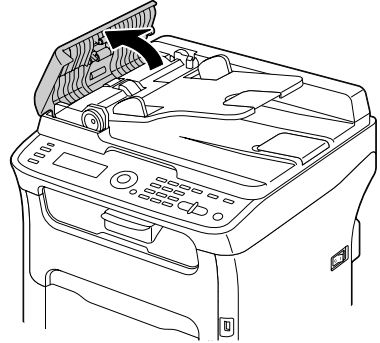

- 2 Remove the document from the ADF document feed tray.

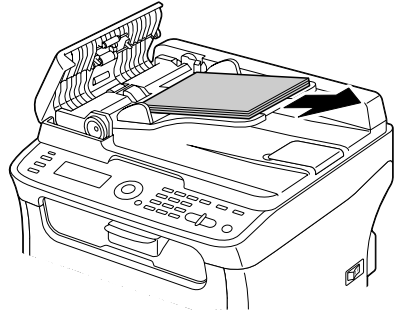

- 3 Lift to open the ADF cover.

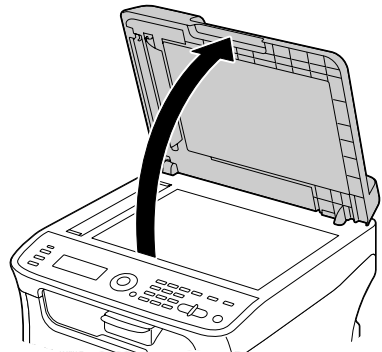

**4** Remove any misfed media.

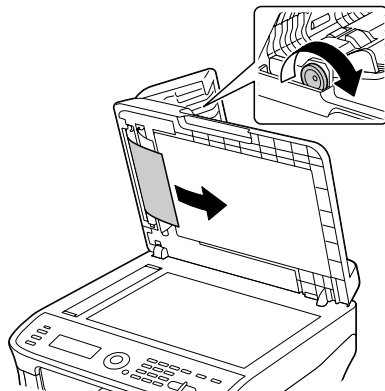

**5** Close the ADF cover.

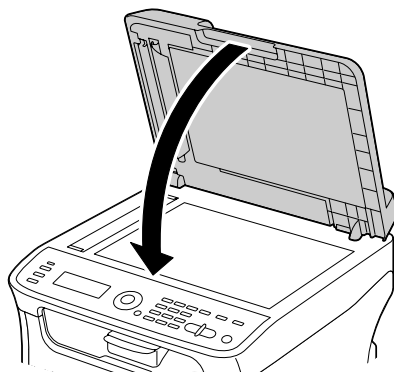

**6** Close the ADF feed cover.

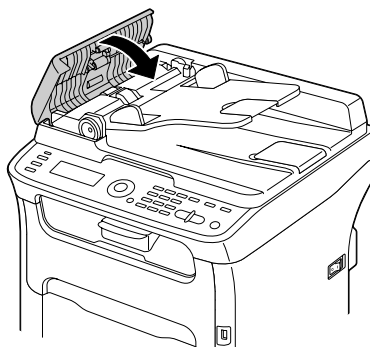

## Clearing a Media Misfeed from the Duplex Option

- 1 Open the duplex cover.

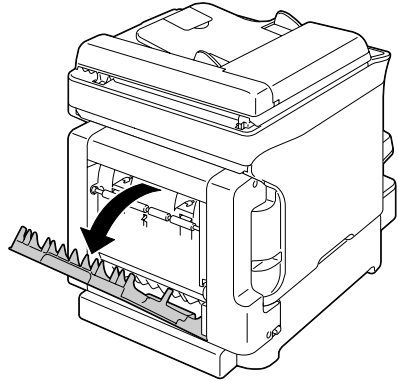

- 2 Carefully pull out the misfed media.



*Always remove the misfed media in the feed direction as shown only.*

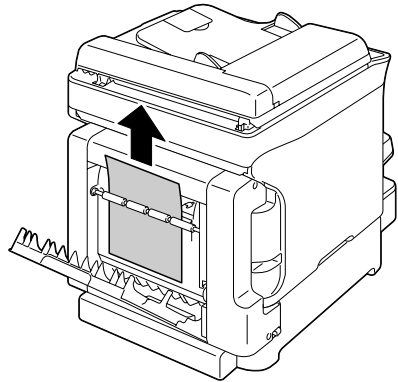

*If the media misfeed occurs at the bottom feed slot and the media does not stick out enough to be removed, turn the dial at the right in the direction of the arrow until the media can be pulled out.*

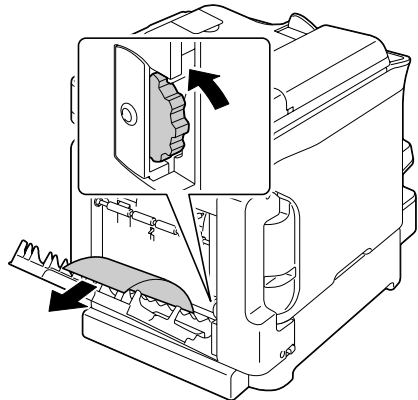

**3** Close the duplex cover.

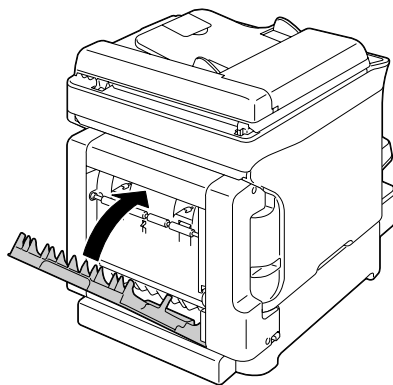

# Solving Problems with Media Misfeeds



*Frequent misfeeds in any area indicate that area should be checked, repaired, or cleaned. Repeated misfeeds may also happen if you're using unsupported print media or original media.*

Symptom	Cause	Solution
Several sheets go through the machine together.	The front edges of the media are not even.	Remove the media and even up the front edges, then reload it.
	The media is moist from humidity.	Remove the moist media and replace it with new, dry media.
Media misfeed message stays on.	Scanner unit needs to be opened and closed again to reset the machine.	Open and close the scanner unit again.
	Some media remains misfed in the machine.	Check the media path again to make sure that you have removed all of the misfed media.
Duplex misfeeds.	Unsupported media (wrong size, thickness, type, etc.) is being used.	Use KONICA MINOLTA-approved media. See "Print Media" on page 3-2. Also, refer to <a href="http://printer.konicaminolta.com">http://printer.konicaminolta.com</a> for a complete list of currently approved media.
		Only Letter/A4 plain paper and recycled paper can be aut duplexed if the media type is set properly in the driver.
		Make sure that you have not mixed media types in the tray.
		Do not duplex envelopes, labels, letter head, postcards or thick stock.
	Media is still being misfed.	Check the media path inside the duplex again to make sure that you have removed all of the misfed media.



<b>Symptom</b>	<b>Cause</b>	<b>Solution</b>
Media is misfed in the ADF.	The loaded document does not meet the specifications.	Load the correct document. For details on the documents that can be loaded, refer to "Documents that can be loaded into the ADF" on page 3-26.
	The loaded document exceeds the maximum capacity.	Load the document so that it does not exceed the maximum capacity. For details on the documents that can be loaded, refer to "Documents that can be loaded into the ADF" on page 3-26.
	The document guides were not slid against the edges of the document.	Slide the document guides against the edges of the document. For details on loading the document, refer to "Loading a document into the ADF" on page 3-29.
Media is misfeeding.	The media is not correctly positioned in the tray.	Remove the misfed media and reposition the media properly in the tray.
	The number of sheets in the tray exceeds the maximum allowed.	Remove the excess media and reload the correct number of sheets in the tray.
	The media guides are not correctly adjusted to the media size.	Adjust the media guides in the Tray 1 to match the size of the media.
	Warped or wrinkled media is loaded in the tray.	Remove the media, smooth it out, and reload it. If it still misfeeds, do not use that media.
	The media is moist from humidity.	Remove the moist media and replace it with new, dry media.
	Envelopes, labels, postcards, thick stock, or letterhead are loaded in Tray 2.	Special media must be loaded in Tray 1 only.
	The recommended label sheet is facing the wrong way in Tray 1.	Load the label sheets according to the manufacturer's instructions.

<b>Symptom</b>	<b>Cause</b>	<b>Solution</b>
Media is mis-feeding.	Envelopes are facing the wrong way in Tray 1.	Load the envelopes in Tray 1 with the flaps facing down.  If the flaps are on the long edge (Envelope C6 and Envelope DL), load the envelopes with the flap edge toward the machine and the flap side facing down.
	Unsupported media (wrong size, thickness, type, etc.) is being used.	Use KONICA MINOLTA-approved media. See "Print Media" on page 3-2.  Also, refer to <a href="http://printer.konicaminolta.com">http://printer.konicaminolta.com</a> for a complete list of currently approved media.
	The media feed roller is dirty.	Clean the media feed roller.  For more details, refer to "Media Rollers" on page 8-5.

# Solving Other Problems

To order KONICA MINOLTA consumables, go to [www.q-shop.com](http://www.q-shop.com).

Symptom	Cause	Solution
Machine power is not on.	The power cord is not correctly plugged into the outlet.	Turn off the machine, confirm that the power cord is correctly plugged into the outlet, and then turn on the machine.
	Something is wrong with the outlet connected to the machine.	Plug another electrical appliance into the outlet and see whether it operates properly.
	The power switch is not correctly turned on (I position).	Turn the power switch off (O position), then turn it back to the on (I position).
	The machine is connected to an outlet with a voltage or frequency that does not match the machine specifications.	Use a power source with the specifications listed in appendix A, "Technical Specifications".
The control panel displays Toner Low much sooner than expected.	One of the toner cartridges may be defective.	Remove the toner cartridges and check for damage. If it is damaged, replace it.
	Printed with heavy toner coverage.	See specifications in Appendix A "Technical Specifications".
Cannot print the machine status list.	The tray is empty.	Check that at least Tray 1 is loaded with media, in place, and secure.
	There is a media misfeed.	Clear the media misfeed.
When the paper type or paper size for Tray 1 is changed, Check Fax Mode appears.	If a fax is received, it could not be printed on paper of the currently specified type or size. However, copy and print operations can be performed.	Press the <b>Fax</b> key, and then check the error details. To print a received fax, change the paper type to PLAIN PAPER and the paper size to A4, LEGAL, LETTER or OFICIO (Mexico only).



<b>Symptom</b>	<b>Cause</b>	<b>Solution</b>
Printing takes too much time.	The machine is set to a slow printing mode (for example, thick stock).	It takes more time to print with special media. When using regular paper, make sure that the media type is set properly in the driver.
	The machine is set to power saving mode.	It takes time for printing to start in power saving mode.
	The job is very complex.	Wait. No action needed.
	A toner cartridge for a different region or an unapproved toner cartridge is installed (Wrong Toner X is displayed in the message window).	Install a correct KONICA MINOLTA toner cartridge approved for your specific machine.
	If an error has been detected during printing job transmission in the Copy mode, it takes a while to process the error and resume the printing operation.	Wait. No action needed.
Blank pages are printed.	One or more of the toner cartridges are defective or empty.	Check the toner cartridges. The image will not print correctly or not at all, if the cartridges are empty.
	The wrong media is being used.	Check that the media type set in the driver matches the media loaded in the machine.
Not all pages print.	A different user accidentally canceled the job.	Try printing the remaining pages.
	The tray is empty.	Check that the tray is loaded with media, in place, and secure.
	A document is printed with an overlay file which has been created by an unsuitable printer driver.	Print the overlay file using a suitable printer driver.

Symptom	Cause	Solution
Some parts of the image are lost with 2in1 copying.	When printing envelopes, the zoom ratio was specified, and then 2in1 copying was set.	With 2in1 copying, the zoom ratio is automatically adjusted. For 2in1 copying on media with a narrow printing area, such as envelopes, set 2in1 copying, and then adjust the zoom ratio, if necessary.
Machine resets or turns off frequently.	The power cord is not correctly plugged into the outlet.	Turn off the machine, confirm that the power cord is correctly plugged into the outlet, and then turn on the machine.
	A system error occurred.	Contact Technical Support with the error information.
You are experiencing duplex problems.	Media or settings are not correct.	Make sure that you are using correct media. <ul style="list-style-type: none"> <li>■ Only Letter/A4 plain paper can be autoduplexed.</li> </ul> Also, refer to <a href="http://printer.konicaminolta.com">http://printer.konicaminolta.com</a> for a complete list of currently approved media. <ul style="list-style-type: none"> <li>■ Do not duplex envelopes, labels, postcards, thick stock, letterheads, or plain paper with a size other than Letter/A4.</li> <li>■ Make sure that you have not mixed media types in the tray.</li> </ul>
		In the printer driver (Layout/Double-Sided), choose “Short Edge Binding” (flipped as on a clipboard) or “Long Edge Binding” (flipped as in a loose-leaf notebook).
		Set duplex (Double-Sided) copying. For details on setting duplex (Double-Sided) copying, refer to “Setting Duplex (Double-Sided) Copying” on page 5-11.
		For N-up on duplexed pages, choose Collate only in the printer driver’s Basic Tab. Do not set collation in the application.

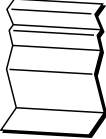

<b>Symptom</b>	<b>Cause</b>	<b>Solution</b>
With N-up on multiple copies, the output is incorrect.	Both the printer driver and the application have been set for collation.	For N-up on multiple copies, choose Collate only in the printer driver's Basic Tab. Do not set collation in the application.
Booklet Left and Right Binding output is incorrect.	Both the printer driver and the application have been set for collation.	For Booklet Left Binding and Booklet Right Binding, choose Collate only in the printer driver's Basic Tab. Do not set collation in the application.
You hear unusual noises.	The machine is not level.	Place the machine on a flat, hard, level surface.
	The tray is not installed correctly.	Remove the tray that you are printing from and reinsert it completely into the machine.
	There is a foreign object stuck inside the machine.	Turn off the machine and remove the object. If you cannot remove it, contact Technical Support.
When copying or scanning with the ADF, a band appears at the end of the image or paper (5 to 6 mm).	A malfunction may have occurred while paper was being transferred with the ADF.	If a band appears in the copy after copying, select a copy density setting that is one level darker.  If a band appears in the image after scanning, scan using the original glass.
Cannot copy with the ADF.	Envelope DL or Envelope C6 is set to the ADF.	Place the document on the original glass. With the Envelope DL size, some areas may not be copied.
Scanned images are noisy.	Resolution is set to 150 x 150 dpi while the scan mode is set to MIX or TEXT.	Set the scan mode to PHOTO.
Some areas of the scanned image are missing.	Acrobat 8 (Macintosh version) is used for scanning the image.	With the Acrobat Scan setting, turn off the OCR and Filtering functions.

Symptom	Cause	Solution
The web-based utility cannot be accessed.	The PageScope Web Connection Administrator's password is incorrect.	The PageScope Web Connection Administrator password has a 4-character minimum and an 8-character maximum. For details of the PageScope Web Connection administrator password, refer to the Reference Guide on the Documentation CD/DVD.
Media is wrinkled. 	The media is moist from humidity or having water spilled on it.	Remove the moist media and replace it with new, dry media.
	The media feed roller or fuser unit is defective.	Check them for damage. If necessary, contact Technical Support with the error information.
	Unsupported media (wrong size, thickness, type, etc.) is being used.	Use KONICA MINOLTA-approved media. See "Print Media" on page 3-2.  Also, refer to <a href="http://printer.konicaminolta.com">http://printer.konicaminolta.com</a> for a complete list of currently approved media.
Data was sent to the machine, but it doesn't print.	An error message is displayed in the message window.	Handle according to the message displayed.
It takes a very long time to transfer scan data to the USB memory device.	The response time may be slow depending on the USB memory device that is used.	Wait until the transfer is finished.
It is not possible to enter Scan mode or Fax mode.	An error has occurred in Copy mode.	Correct the cause of the error, and then enter a different mode.



# Solving Problems with Printing Quality



Symptom	Cause	Solution
Nothing is printed, or there are blank spots on the printed page. 	One or more of the toner cartridges may be defective.	Remove the toner cartridges and check if any is damaged.
	The imaging cartridge may be defective.	Remove the imaging cartridge and check for damage. If it is damaged, replace it.
	The media is moist from humidity.	Adjust the humidity for media storage. Remove the moist media and replace it with new, dry media.
	The media set in the printer driver mismatches the media loaded in the machine.	Load the correct media in the machine.
	The power source does not match the machine specifications.	Use a power source with the proper specifications.
	Several sheets are being fed at the same time.	Remove the media from the tray and check for static electricity. Fan plain paper or other media, and replace it in the tray.
	Media is not set properly in the tray(s).	Remove the media, tap it to straighten it out, return it to the tray, and realign the media guides.
Entire sheet is printed in black or color. 	One or more of the toner cartridges may be defective.	Remove the toner cartridges and check for damage. If it is damaged, replace it.
	The imaging cartridge may be defective.	Remove the imaging cartridge and check for damage. If it is damaged, replace it.



Symptom	Cause	Solution
Image is too light; there is low image density. 	The print head window is dirty.	Clean the print head window.
	The copy density is set too light.	Select a darker copy density.
	The media is moist from humidity.	Remove the moist media and replace with new, dry media.
	There is not much toner left in the cartridge.	Replace the toner cartridge.
	One or more of the toner cartridges may be defective.	Remove the toner cartridges and check for damage. If it is damaged, replace it.
	Media type is set incorrectly.	When printing envelopes, labels, letterhead, postcards or thick stock, specify the appropriate media type in the printer driver.
Image is too dark. 	The copy density is set too dark.	Select a lighter copy density.
	The document was not pressed close enough against the original glass.	Position the document so that it is pressed close enough against the original glass. For details on positioning the document on the original glass, refer to "Placing a document on the original glass" on page 3-28.
	One or more of the toner cartridges may be defective.	Remove the toner cartridges and check for damage. If it is damaged, replace it.
	The imaging cartridge may be defective.	Remove the imaging cartridge and check for damage. If it is damaged, replace it.

Symptom	Cause	Solution
Image is blurred; background is lightly stained; there is insufficient gloss of the printed image.	One or more of the toner cartridges may be defective.	Remove the toner cartridges and check for damage. If it is damaged, replace it.
	The imaging cartridge may be defective.	Remove the imaging cartridge and check for damage. If it is damaged, replace it.
	The original glass is dirty.	Clean the original glass. For details, refer to "Cleaning the Machine" on page 8-4.
	The original cover pad is dirty.	Clean the original cover pad. For details, refer to "Cleaning the Machine" on page 8-4.
The print or color density is uneven.	One or more of the toner cartridges may be defective or low.	Remove the toner cartridges and check for damage. If it is damaged, replace it.
	The imaging cartridge may be defective.	Remove the imaging cartridge and check for damage. If it is damaged, replace it.
	The machine is not level.	Place the machine on a flat, hard, level surface.
Irregular print or mottled image appears.	The media is moist from humidity.	Adjust the humidity in the media storage area.  Remove the moist media and replace it with new, dry media.
	Unsupported media (wrong size, thickness, type, etc.) is being used.	Use KONICA MINOLTA-approved media. See "Print Media" on page 3-2.  Also, refer to <a href="http://printer.konicaminolta.com">http://printer.konicaminolta.com</a> for a complete list of currently approved media.
	One or more of the toner cartridges may be defective.	Remove the toner cartridges and check for damage. If it is damaged, replace it.
	The imaging cartridge may be defective.	Remove the imaging cartridge and check for damage. If it is damaged, replace it.

Symptom	Cause	Solution
<p>There is insufficient fusing or the image comes off when rubbed.</p> 	The media is moist from humidity.	Remove the moist media and replace it with new, dry media.
	Unsupported media (wrong size, thickness, type, etc.) is being used.	Use KONICA MINOLTA-approved media. See "Print Media" on page 3-2.  Also, refer to <a href="http://printer.konicaminolta.com">http://printer.konicaminolta.com</a> for a complete list of currently approved media.
	Media type is set incorrectly.	When printing envelopes, labels, letterhead, postcards or thick stock, specify the appropriate media type in the printer driver.
<p>There are toner smudges or residual images.</p> 	One or more of the toner cartridges are defective or installed incorrectly.	Remove the toner cartridges and check for damage. If it is damaged, replace it.
<p>There are toner smudges on the back side of the page (whether or not it has been duplexed).</p> 	The media path is dirty with toner.	Print several blank sheets and the excess toner should disappear.
	One or more of the toner cartridges are defective.	Remove the toner cartridges and check for damage. If it is damaged, replace it.
	The imaging cartridge may be defective.	Remove the imaging cartridge and check for damage. If it is damaged, replace it.

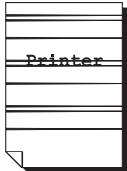
Symptom	Cause	Solution
Abnormal areas (white, black, or color) appear in a regular pattern. 	The print head window is dirty.	Clean the print head window.
	A toner cartridge may be defective.	Remove the toner cartridges with the color causing the abnormal image. Replace it with a new toner cartridge.
	The imaging cartridge may be defective.	Remove the imaging cartridge and check for damage. If it is damaged, replace it.
Image defects. 	The print head window is dirty.	Clean the print head window.
	A toner cartridge may be leaking.	Remove the toner cartridges and check for damage. If it is damaged, replace it.
	A toner cartridge may be defective.	Remove the toner cartridge with the color causing the abnormal image. Replace it with a new toner cartridge.
	The imaging cartridge may be defective.	Remove the imaging cartridge and check for damage. If it is damaged, replace it.
Lateral lines or bands appear on image. 	The machine is not level.	Place the machine on a flat, hard, level surface.
	The media path is dirty with toner.	Print several sheets and the excess toner should disappear.
	One or more of the toner cartridges may be defective.	Remove the toner cartridges and check for damage. If it is damaged, replace it.
	The imaging cartridge may be defective.	Remove the imaging cartridge and check for damage. If it is damaged, replace it.
Colors look drastically wrong.	One or more of the toner cartridges may be defective.	Remove the toner cartridges and verify that the toner is distributed evenly on each cartridge roller, and reinstall the toner cartridges.

<b>Symptom</b>	<b>Cause</b>	<b>Solution</b>
Colors are not registering properly; colors are mixed or have page-to-page variation.	The scanner unit or front cover is opened during the calibration.	Set MACHINE SETTING/CALIBRATION in the UTILITY menu to ON, and then perform the AIDC color calibration. For details, refer to "MACHINE SETTING Menu" on page 2-22.
	Gradations are not adjusted correctly.	
	The imaging cartridges is not correctly seated.	Remove the imaging cartridge and check for damage. If it is damaged, replace it.
	One or more of the toner cartridges may be defective.	Remove the toner cartridges and check for damage. If it is damaged, replace it.
	The media is moist from humidity.	Remove the moist media and replace it with new, dry media.
The color has a poor reproduction or has poor color density. 	The imaging cartridge may be defective.	Remove the imaging cartridge and check for damage. If it is damaged, replace it.

If the problem is not resolved, even after all of the above have been performed, contact Technical Support with the error information.

For contact information, refer to the Need Assistance sheet.

# Status, Error, and Service Messages

Status, error, and service messages are displayed in the message window. They provide information about your machine and help you locate many problems. When the condition associated with a displayed message has changed, the message is cleared from the window.

## Status Messages

This message...	means...	Do this...
(Nothing displayed)	The machine is in Energy Save mode to reduce power consumption during periods of inactivity.	No action needed.
ACCEPTED	The settings were applied.	
DATA RECEIVING	This machine is receiving data.	
NONE	The object does not exist.	
PC SCAN CANCEL	The scan job was canceled from the driver.	
PLEASE WAIT!	<p>The AIDC color calibration is being performed.</p> <p>The AIDC color calibration is performed automatically in the following circumstances.</p> <ul style="list-style-type: none"><li>■ When the machine is turned on</li><li>■ When the machine recovers from Energy Save (Sleep) mode</li><li>■ When the machine is restarted after settings have been changed</li><li>■ After a toner cartridge is replaced</li></ul> <p>This process maintains optimum print quality.</p>	
PRINT WAITING	The machine is waiting to print.	
PRINTING	The machine is printing.	

This message...	means...	Do this...
SEARCHING	The machine is searching data.	
SCANNING	The machine is scanning the document.	
Warming Up	The machine is warming up or AIDC is being performed.	

## Error Messages



For details on fax error messages, refer to the *Facsimile User's Guide on the Documentation CD/DVD*.

This message...	means...	Do this...
ADDRESS IS TOO LONG	The e-mail address retrieved from the LDAP server exceeds 64 characters.	This machine can handle addresses containing no more than 64 bytes. Use a shorter address.
CANNOT CONNECT xxx Server	A connection with the specified server could not be established.	Check the settings specified in the NETWORK SETTING and E-MAIL SETTING menus, and then try sending the data again.
CANNOT GET IP xxx Server	The IP address of the specified server could not be obtained from the DNS server.	Check the settings specified in the NETWORK SETTING and E-MAIL SETTING menus, and then try sending the data again.
CHECK TRAY1 PAPER LOAD PAPER ( <sup>1</sup> xx) (PRESS START KEY)	Tray1 has run out of paper.	Load media into the tray, and then press the <b>Start</b> key.
	Media has misfed in Tray 1.	Remove the misfed media.

<b>This message...</b>	<b>means...</b>	<b>Do this...</b>
COMMUNICATION ERROR USB Memory	While data was being sent in Scan mode, the connection to the USB memory device was interrupted.	Check the connection to the USB memory device, and then try sending the data again.
COMMUNICATION ERROR xxx Server	While data was being sent in Scan mode, the connection to the server was interrupted.	Check the settings specified in the NETWORK SETTING and E-MAIL SETTING menus, and then try sending the data again.
DISCONNECT USB Memory	The connection to the USB memory device was interrupted.	Check the connection to the USB memory device, and then try sending the data again.
DISCONNECT xxx Server	The connection to the server was interrupted.	Check the settings specified in the NETWORK SETTING and E-MAIL SETTING menus, and then try sending the data again.
DESTINATION SET BY MANUAL UP TO 16	There were more than 16 addresses found with an LDAP search.	Increase the number of entered characters, and then perform the search again.
I/C END	The time to replace the imaging cartridge has been reached.	Replace the imaging cartridge.
I/C LIFE END REPLACE I/C	The time to replace the imaging cartridge has been reached.	Replace the imaging cartridge.
I/C LOW	The imaging cartridge is nearly empty.	Prepare the imaging cartridge.



<b>This message...</b>	<b>means...</b>	<b>Do this...</b>
JOB CANCELED	While a document was being scanned from the original glass in Scan mode, more than one minute had passed after the first page of the document was scanned or the data could not be sent. Therefore, the scan job was automatically canceled.	Turn the machine off, and then, after waiting a few seconds, turn it on again. When sending multiple pages, for example, from a book, scan the first page, and then scan the next page within one minute.
MEMORY FILE FULL	The maximum number of image data files has been reached.	Turn the machine off, and then, after a few seconds, turn it on again. Decrease the amount of data to be printed (for example, by decreasing the resolution), and then try printing again.
MEMORY FULL	The machine has received more data than can be processed with its internal memory.	Turn the machine off, and then, after a few seconds, turn it on again. Decrease the amount of data to be printed (for example, by decreasing the resolution), and then try printing again.
NO NETWORK SETTING	The network settings had not been completely specified when the machine was switched to Scan mode.	Before scanning in Scan mode, specify the network settings in the NETWORK SETTING and E-MAIL SETTING menus.

<b>This message...</b>	<b>means...</b>	<b>Do this...</b>
NO SUITABLE PAPER CHECK DUPLEX SETTING	Duplex (double-sided) printing is specified, but paper with a type or size incompatible with duplex (double-sided) printing is selected.	Select Letter- or A4-size plain paper, or select simplex (single-sided) printing, and then try performing the print job again.
NO SUITABLE PAPER LOAD PAPER (xxx)	Paper suitable for printing is not loaded in a paper tray.	Load paper suitable for printing into a paper tray.
NOT E-MAIL ADDRESS	When the destination for the scan data was specified, a fax number registered in the favorite list or as a speed dial destination or group dial destination has been selected.	Directly type in the destination for the scan data, or specify an e-mail address registered in the favorite list or as a speed dial destination or group dial destination.  When sending scan data to an FTP address or SMB address, only one address can be specified. Delete all specified destinations, or send the scan data, then scan again.
NOT INSTALLED TONER CHECK x TONER	The indicated toner cartridge is not installed.	Install the indicated toner cartridge.
NOT REGISTERED	No speed dial destination or group dial destination is registered.  Otherwise, no destination has been registered with the specified speed dial or group dial number.	Directly type in the destination address for the scan data, or register a speed dial destination or group dial destination and try specifying the destination address again.

This message...	means...	Do this...
OUTPUT TRAY FULL REMOVE PAPER	The output tray is full of paper.	Remove all paper from the output tray.
OVER SEARCH TIME	Communication with the LDAP server has timed out.	Establish a connection with the LDAP server again.
PAPER EMPTY LOAD PAPER ( <sup>2</sup> xx)	Tray 2 has run out of paper.	Load media into the tray.
PAPER SIZE ERROR RESET PAPER (xxx)	The size of paper being printed on is different from the size of paper specified in the printer driver.	Press the <b>Start</b> key to cancel the caution.  To print on paper of the size specified in the printer driver, load paper of the correct size into the specified tray, and then try performing the print job again.
PC CONNECTION FAILED	While data was being sent in Scan mode, the connection to the computer was interrupted.	Check the connection with the computer and the scanner driver status, and then try sending the data again.
Process Caution - IDC	A process error occurred in the machine.	Open and close the scanner unit.
PROCESS ERROR-xxx CLEAR BY COVER		
REMOVE ORIGINAL IN ADFR	The document is loaded in the ADF while a function is set that requires scanning from the original glass.	Place the document on the original glass.

This message...	means...	Do this...
RESULTS ARE OVER xxx	The LDAP search results exceed the maximum specified with MAX . SEARCH RESULT in the LDAP SETTING menu.	Change the maximum setting, or change the search conditions (for example, increase the length of the keyword), and then try performing the LDAP search again.
RETURN xx ORIGINAL to ADF and PRESS START KEY	After a media misfeed has been cleared from the ADF, the number of document pages to be reloaded into the ADF is indicated.	Reload into the ADF the number of document pages indicated by xx, and then press the <b>Start</b> key.
SERVER MEMORY FULL SMTP Server	The memory of the SMTP server has become full.	Free up some space on the disk, for example, by contacting your server administrator.
THE PARTY IS FULL	The maximum number of 236 destinations for the scan data has been reached.	Send the data, and then try scanning again. Otherwise, delete unnecessary destinations before adding the desired ones.
TONER LIFE END CHANGE x TONER	The indicated toner cartridge has become empty.	Replace the indicated toner cartridge.
TONER OUT CHANGE x TONER	The indicated toner cartridge has become empty. (This message appears if TONER OUT STOP on the MACHINE SETTING menu is set to ON or ON (FAX) .)	Replace the indicated toner cartridge.
Toner Low x	The indicated toner cartridge is nearly empty.	Prepare the indicated toner cartridge.

<b>This message...</b>	<b>means...</b>	<b>Do this...</b>
TRAY2 OPEN CLOSE TRAY2	Tray 2 cassette is open.	Close the tray.
T/C Memory Error	A memory error occurred in the toner cartridge.	Re-install the specified toner cartridge.
USB Dev. Not support	A USB device incompatible with this machine is connected.	Disconnect the USB device from this machine.
USB Hub Not support	A USB hub is connected to this machine.	This machine is not compatible with a USB hub. When connecting USB cables to this machine, do not use a USB hub.
USB MEMORY FULL	There is no space available on the USB memory device connected to this machine.	Delete data from the USB memory device to create free space, or use a different USB memory device.
Video I/F Error	A video interface error occurred in the machine.	Turn off the machine. After a few seconds, turn on the machine.
WRONG PASSWORD xxx Server	The password is incorrect, so the indicated server could not be accessed.	Check the password, and then specify the correct one.
Wrong Toner x	An unapproved toner cartridge is installed.	Install a correct KONICA MINOLTA toner cartridge.
xxx COVER OPEN CLOSE xxx COVER	The indicated cover is open.	Close the indicated cover.
	The imaging cartridge is not installed.	Install the imaging cartridge.
	A imaging cartridge incompatible with the machine is installed.	Replace the imaging cartridge with a correct one.

<b>This message...</b>	<b>means...</b>	<b>Do this...</b>
xxx IS DISABLED	The TCP/IP, FTP, SMTP or SMB settings are disabled.	Enable the TCP/IP, FTP, SMTP or SMB settings.
xxxxx IS NOT SUPPORTED	Repeat copying cannot be performed with the specified paper size.	The maximum possible size for repeat copying is A4.  Specify a paper size of A4 or smaller.
xxx SERVER ERROR	The file cannot be saved on the indicated server.	Check the status of the indicated server.

## Service Messages

These messages indicate a more serious fault that can only be corrected by a customer service engineer. If one of these messages appears, turn the machine off, then turn it on again. If the problem persists, contact your local vendor or authorized service provider.

<b>This service message...</b>	<b>means...</b>	<b>Do this...</b>
MACHINE TROUBLE SERVICE CALL (xxxxx)	An error has been detected with the item indicated "xxxxx" in the service message.	Reboot the machine. This often clears the service message, and machine operation can resume.  If the problem persists, contact Technical Support.

# *Installing Accessories* 10





# Introduction

---

---

## Note

---



---

**Any damage to the machine caused by the use of accessories not manufactured or supported by KONICA MINOLTA will void your warranty.**

---

---

This chapter provides information about the following accessories.

<b>Tray 2</b>	Lower feeder unit with 500-sheet tray included
<b>Duplex Option</b>	Auto duplexing  <i>In order for the duplex option to be installed, Tray 2 must be installed on the machine.</i>
<b>Duplex Option and Attachment</b>	Auto duplexing  <i>The attachment is an interface unit for installing the duplex option on the machine.</i>  <i>During installation, install the attachment before installing the duplex option.</i>

---

---

## Note

---

---

**Installing accessories always requires that the machine and accessories are turned off and unplugged during installation.**

---

---



*For details on the available options, refer to <http://printer.konicaminolta.com>.*

## Tray 2 (Lower Feeder Unit)

You can install up to one optional lower feeder unit (Tray 2). The lower feeder unit increases your machine's media feed capacity by 500 sheets.

### Kit Contents

- Lower feeder unit with a tray (500-sheet capacity)

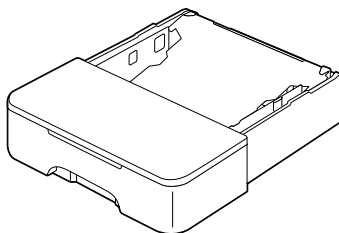
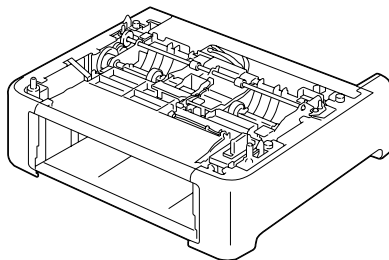

## Installing Tray 2

### Note

Since consumables are installed in the machine, be sure to keep the machine level when moving it in order to prevent accidental spills.

- 1 Turn off the machine and disconnect the power cord and interface cables.

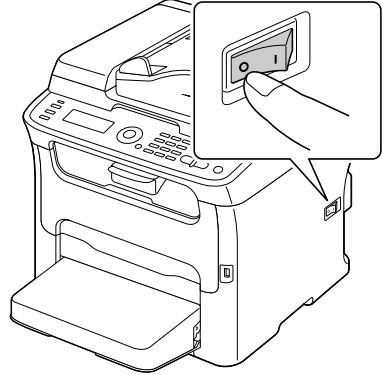

- 2 Remove the dust cover from Tray 1.  
Close Tray 1 and the output tray.

- 3 Prepare the lower feeder unit.



*Be sure to place the lower feeder unit on a level surface.*

- 4 Lift the machine and place it on top of the lower feeder unit, making sure that the positioning pins on the lower feeder unit correctly fit into the holes on the bottom of the machine.

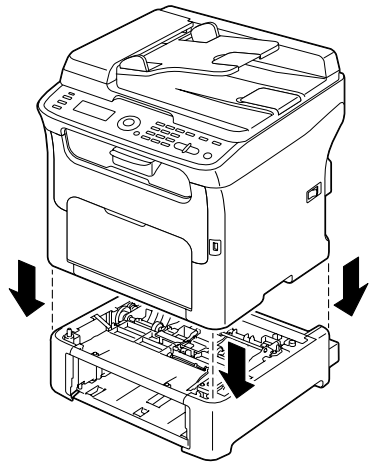



## WARNING!

**This machine weighs approximately 21 kg (46 lb) when it is fully loaded with consumables.**

- 5 Open Tray 1 and reattach the dust cover.
- 6 Load paper into Tray 2.  
For details on loading paper, refer to “Tray 2” in “Loading Media” on pages.
- 7 Insert Tray 2 into the machine.

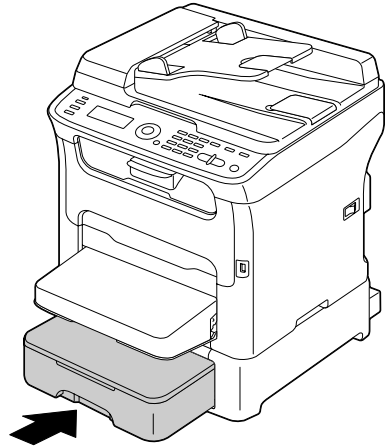

- 8** When installing Tray 2 without installing the duplex option, also install the locking pins (one in each opening on the left and right sides at the back of Tray 2).

While holding the grip of the locking pin vertical, insert the locking pin into the opening on either the left or right side of the lower feeder unit and, while pushing it in, turn it to either the left or the right. The locking pin is installed when its grip is horizontal.

Installing the left and right locking pins secures the lower feeder unit to the machine so it cannot be removed.



*This step can be skipped if the duplex option is to be installed after installing Tray 2.*

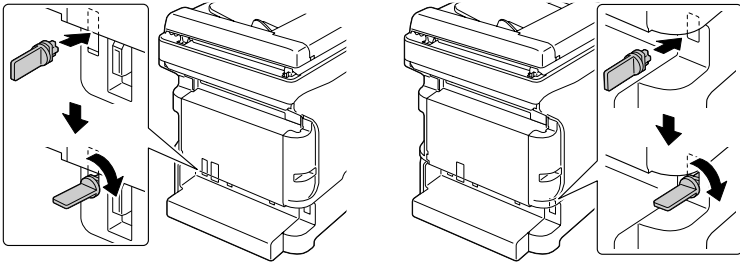

*To uninstall the lower feeder unit from the machine, remove the locking pins on the left and right side at the back of Tray 2, and then remove the lower feeder unit. To remove a locking pin, turn it to either the left or the right so that its grip is vertical, and then pull out the locking pin to remove it.*

- 9** Reconnect all interface cables.
- 10** Reconnect the power cord, and turn on the machine.

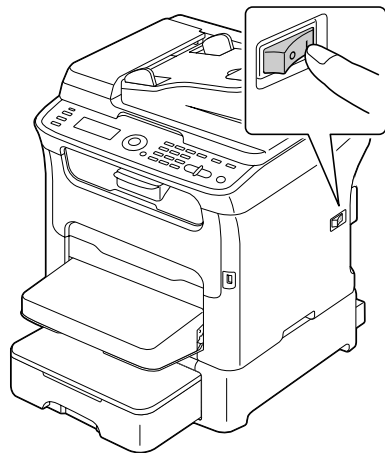

# Duplex Option

Duplex (Double-Sided) printing can be performed automatically with the duplex option installed.

For details, refer to “About Duplex Printing” on page 3-22.

In order for the duplex option to be installed, either of the following must be installed on the machine.

- Tray 2
- Attachment

## Kit Contents

Duplex option

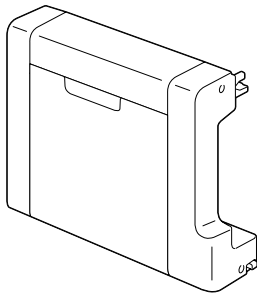

Attachment

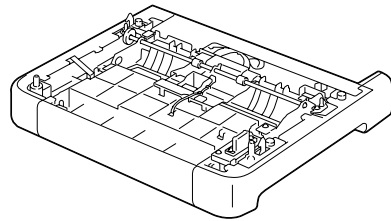

*If Tray 2 is installed, it is not necessary to install the attachment. In this case, skip “Installing the Attachment”, and continue with “Installing the Duplex option” on page 10-9.*

## Installing Attachment

If the attachment is installed, the duplex option can be installed.

(The attachment cannot be used by itself; it must be used together with the duplex option.)

### Note

**Since consumables are installed in the machine, be sure to keep the machine level when moving it in order to prevent accidental spills.**

- 1 Turn off the machine and disconnect the power cord and interface cables.

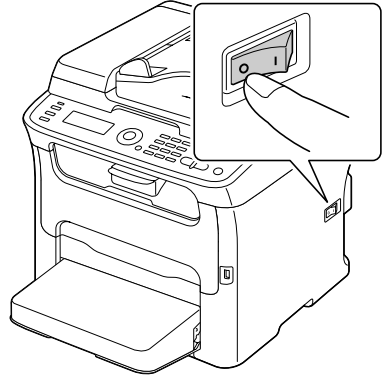

- 2 Remove the dust cover from Tray 1. Close Tray 1 and the output tray.
- 3 Prepare the attachment.



*Be sure to place the attachment on a level surface.*

- 4 Lift the machine and place it on top of the attachment, making sure that the positioning pins on the attachment correctly fit into the holes on the bottom of the machine.

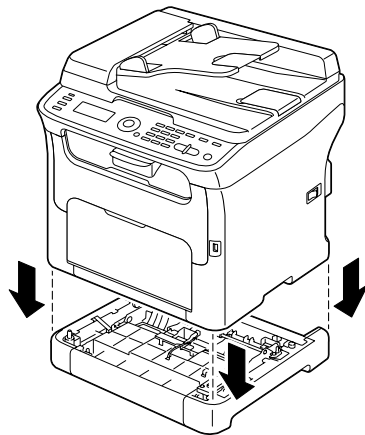



## WARNING!

**This machine weighs approximately 21 kg (46 lb) when it is fully loaded with consumables.**

**5** Open Tray 1 and reattach the dust cover.

Next, install the duplex option.

### Installing the Duplex option



*The illustrations in the following installation procedure show the machine with Tray 2 installed; however, the installation procedure would be the same if the attachment was installed.*

**1** Turn off the machine and disconnect the power cord and interface cables.

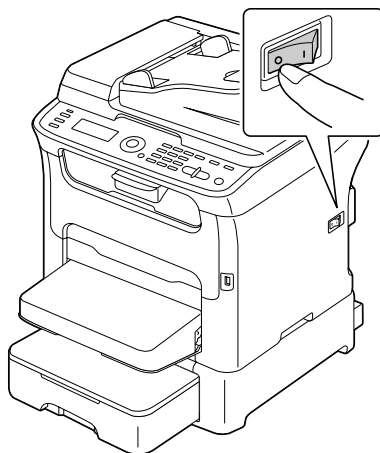



- 2** Remove the tape affixed to the rear cover.

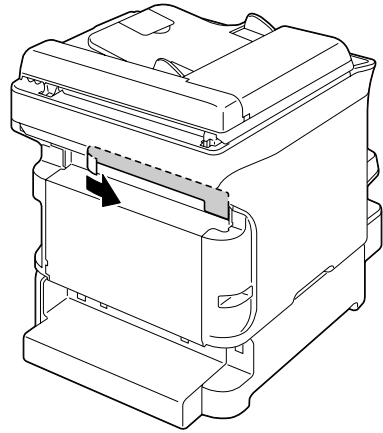

- 3** If the locking pins are installed on the left and right side at the back of Tray 2, remove them.  
To remove a locking pin, turn it to either the left or the right so that its grip is vertical, and then pull out the locking pin to remove it.

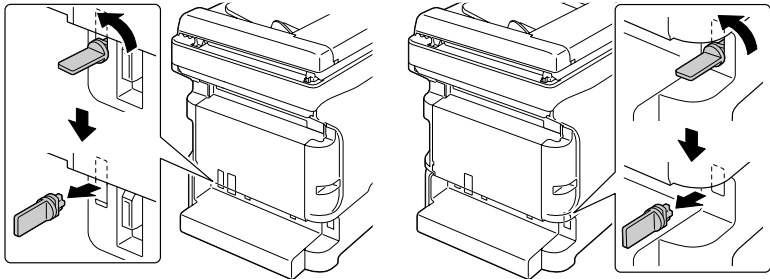

- 4** Prepare the duplex option.

- 5** Install the duplex option.  
Align the duplex option with its installation position, and then push down on the bottom of the duplex option until it locks into place.

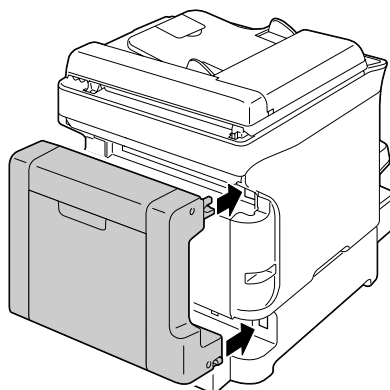
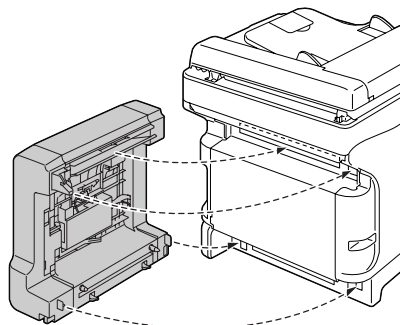

---

### Note

**When attaching the duplex option, attach the bottom of the option first. If the duplex option is attached incorrectly, it may be damaged.**

---

- 6** Open the duplex cover.  
While holding the duplex option against the machine, tighten the screws inside the cover to complete the installation of the duplex option.

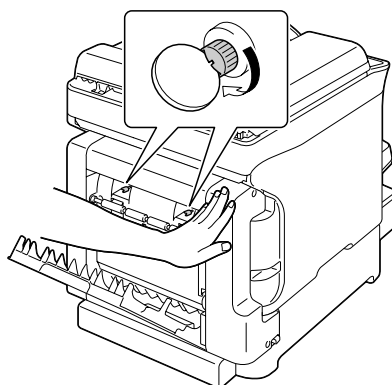

- 7** Reconnect all interface cables.

- 8 Reconnect the power cord, and turn on the machine.

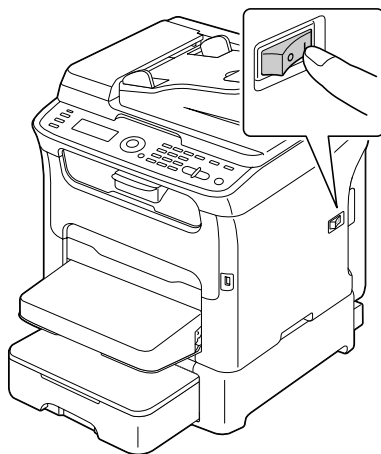

*Appendix* **A**



# Technical Specifications

Type	Desktop (Full color laser beam printer-based all-in-one)
Document holder	Stationary
Developing system	Mono component development system
Fusing system	Heat roller system
Resolution	1200 dpi × 600 dpi or 600 dpi × 600 dpi
First print	Simplex <ul style="list-style-type: none"><li>■ Monochrome 12 seconds for A4/Letter (plain paper)</li><li>■ Full color 21 seconds for A4/Letter (plain paper)</li></ul>
First copy	Simplex <ul style="list-style-type: none"><li>■ Monochrome 23 seconds for A4/Letter (plain paper) (Normal 600 x 300 dpi)</li><li>■ Full color 52 seconds for A4/Letter (plain paper) (Normal 600 x 300 dpi)</li></ul>
Print speed	Simplex <ul style="list-style-type: none"><li>■ Monochrome 20 pages per minute for A4, Letter (plain paper)</li><li>■ Full color 5 pages per minute for A4, Letter (plain paper)</li></ul>

Copy speed	<p>Simplex</p> <ul style="list-style-type: none"> <li>■ Monochrome 20* pages per minute for A4 (plain paper) (Normal 600 x 300 dpi)</li> <li>* When using ADF: 20 pages per minute (Normal 300 × 300 dpi) 10 pages per minute (Fine 600 × 300 dpi)</li> <li>■ Full Color 5* pages per minute for A4 (plain paper) (Normal 600 x 300 dpi)</li> <li>* When using ADF: 3.3 pages per minute (Normal 300 × 300 dpi/Fine 600 × 300 dpi)</li> </ul>
Warm-up time	Avg. 30 seconds (time to return to Ready mode from Energy Save mode)
Media sizes	<p>Tray 1 (Multipurpose tray)</p> <ul style="list-style-type: none"> <li>■ Paper width: 92 to 216 mm (3.6" to 8.5")</li> <li>■ Paper length: Plain paper: 195 to 356 mm (7.7" to 14.0") Thick stock 1/2: 184 to 297 mm (7.25" to 11.7")</li> </ul> <p>Tray 2 (optional) Letter or A4</p>
Paper/Media	<p>Plain paper (60 to 90 g/m<sup>2</sup>)</p> <p>Letterhead</p> <p>Envelopes</p> <p>Labels</p> <p>Thick stock 1 (91 to 163 g/m<sup>2</sup>)</p> <p>Thick stock 2 (164 to 209 g/m<sup>2</sup>)</p> <p>Postcard</p>

Input capacity	<p>Tray 1 (multipurpose tray)</p> <ul style="list-style-type: none"> <li>■ Plain/recycled paper: 200 sheets</li> <li>■ Envelopes: 10 envelopes</li> <li>■ Letterhead, labels, thick stock 1/2, postcard: 50 sheets</li> </ul> <p>Tray 2 (optional)</p> <p>Plain/recycled paper: 500 sheets</p>
Output capacity	Output tray: 100 sheets
Operating temperature	10 to 35 °C (50 to 95 °F)
Operating humidity	15% to 85%
Power supply	120 V, 50 to 60 Hz 220 to 240 V, 50 to 60 Hz
Power consumption	120 V: 990 W or less 220 to 240 V: 1060 W or less Energy Saver Mode: 14 W or less
Amperage	120V : 8.4 A or less 220 to 240 V: 4.4 A or less
Acoustic noise	Standby: 38 dB or less Printing: 49 dB or less
External dimensions	Height: 432 mm (17.0") Width: 405 mm (15.9") Depth: 427 mm (16.8")
Weight	19 kg (without consumables) 21 kg (with consumables)
Interface	USB 2.0 (High Speed) compliant, 10/100Base-T Ethernet, Host USB (for Scan to USB Memory)
Standard memory	128 MB

# Consumable Life Expectancy Chart

## User-Replaceable

Item	Average Life Expectancy
Toner cartridge	<b>Starter Cartridge</b> = 500 pages (Y, M, C) 1,000 pages (K) <b>Replacement Cartridge</b> = Standard-capacity: 1,500 pages (Y, M, C) High-capacity: 2,500 pages (Y, M, C, K)
Imaging cartridge	<b>Monochrome:</b> 45,000 pages (Continuous) 10,000 pages (1 page per job) <b>Full color:</b> 11,250 pages (Continuous) 7,500 pages (1 page per job)
Fuser unit	50,000 pages
 A constant environment is one with a temperature between 15 °C (59 °F) and 25 °C (77 °F) and humidity between 35% and 70%.	



The values shown for the toner cartridge and waste toner bottle indicate the number of pages for simplex printing using A4/Letter-size media with 5% coverage.

The actual life may differ (be shorter) depending on the printing conditions (coverage, paper size, etc.), differences in the printing method, such as continuous printing or intermittent printing (when print jobs of one page are often printed), or the type of paper used, for example, thick paper. In addition, the life will be affected by the temperature and humidity of the operating environment.

## Service-Replaceable

Item	Average Life Expectancy
Transfer roller	50,000 pages



# Entering Text

When specifying the user name or programming the recipient name, letters, accented characters, numbers and symbols can be entered.

## Key Operation

Use the keypad to enter numbers, letters, and symbols.

List of characters available with each key of the keypad

## Entering Fax Numbers

Keypad Key	Available characters	Available characters (Registration of USER FAX NO.) *	
	[1...]	[1...]	[A...]
1	1	1	-1
2	2	2	2
3	3	3	3
4	4	4	4
5	5	5	5
6	6	6	6
7	7	7	7
8	8	8	8
9	9	9	9
0	0	0	(space)0
*	*		
#	#		+

\* To display your fax number, select ADMIN. MANAGEMENT/USER SETTING/USER FAX NUMBER in the UTILITY menu. For details, refer to the Facsimile User's Guide on the Documentation CD/DVD.

## Entering Names

Keypad Key	Available characters	
	[1...]	[A...]
1	1	.,'?¿! "1-()@/;:_
2	2	ABC2abcÆÇàáâãääåæç
3	3	DEF3defÐèéêëèð
4	4	GHI4ghiiíîï
5	5	JKL5jkl€£¢
6	6	MNO6mnoØŒñòóôõöøœ°
7	7	PQRS7pqrsß\$
8	8	TUV8tuvùúûü
9	9	WXYZ9wxyzÞýþ
0	0	(space)0
*		
#	#	*+x+=#%&<>[]{} µ^`~

## Entering E-mail Addresses

Keypad Key	Available characters	
	[1...]	[A...]
1	1	.@_-1
2	2	ABC2abc
3	3	DEF3def
4	4	GHI4ghi
5	5	JKL5jkl
6	6	MNO6mno
7	7	PQRS7pqrs
8	8	TUV8tuv
9	9	WXYZ9wxyz
0	0	(space)0
*		
#	#	+&/*=!?(%)%[]^`{ ~\$,:.

## Changing Input Mode

Each press of the  $\times$  key switches the input mode between numbers and letters.

[1...]: Numbers can be typed in.

[A...]: Letters can be typed in.

## Inputting Example

The procedure for entering text is described below, using "NJ Office" as an example.

- 1** Press the  $\times$  key to change the input mode so that letters can be entered.
- 2** Press the **6** key twice.  
"N" is entered.
- 3** Press the **5** key once.  
"J" is entered.
- 4** Press the **0** key once.  
A space is entered.
- 5** Press the **6** key three times.  
"O" is entered.
- 6** Press the **3** key seven times.  
"f" is entered.
- 7** Press the **▶** key.  
The cursor moves to the right.
- 8** Press the **3** key seven times.  
"f" is entered.
- 9** Press the **4** key seven times.  
"i" is entered.
- 10** Press the **2** key seven times.  
"c" is entered.
- 11** Press the **3** key six times.  
"e" is entered.

## Correcting Text and Input Precautions

- To erase all entered text, hold down the **Back** key.
- To delete only part of the entered text, use the ◀ and ▶ keys to move the cursor ( ) to the character that you want to delete, and then press the **Back** key.
- If multiple characters are assigned to a single key, “OK=▶” appears at the bottom of the screen.
- If the same key is to be used to enter two characters in a row, press the ▶ key after selecting the first character. (Refer to the above inputting example.)
- To enter a space, press the **0** key.

# Our Concern for Environmental Protection



As an ENERGY STAR® Partner, we have determined that this machine meets the ENERGY STAR Guidelines for energy efficiency.

## **What is an ENERGY STAR product?**

An ENERGY STAR product has a special feature that allows it to automatically switch to a “low-power mode” after a period of inactivity. An ENERGY STAR product uses energy more efficiently, saves you money on utility bills and helps protect the environment.

---

# Index

---

## Numerics

2in1 copy .....5-6

## A

### Address book

Searching address .....6-15

Selecting address .....6-15

Admin. Management menu .....2-28

Attachment .....10-7

## B

Basic tab .....4-6

## C

Collated copy .....5-13

Configuration menu .....2-20

### Consumables

Fuser unit .....7-15

Imaging cartridge .....7-11

Toner cartridge .....7-2

Control panel .....2-2

Copy .....5-2

2in1 copy .....5-6

Collated copy .....5-13

Copy density .....5-4

Copy mode .....5-3

Duplex .....5-11

ID card copy .....5-8

Poster copy .....5-10

Repeat copy .....5-9

Select media tray .....5-5

Zoom ratio .....5-4

Copy Setting menu .....2-42

## D

Dial Register menu .....2-44

Duplex copy .....5-11

Duplex Option .....10-7

Duplex printing .....3-22

## E

**Entering text** ..... A-6  
  Correcting text ..... A-9  
  Input mode ..... A-8  
  Input precautions ..... A-9  
**Envelope** .....3-5

## F

**Favorite list**  
  Deleting address .....6-20  
  Registering address .....6-19, 6-20  
  Selecting address .....6-13  
**FAX RX Operation menu** .....2-47  
**FAX TX Operation menu** .....2-45

## G

**Group dial**  
  Editing/deleting address .....6-25  
  Registering address .....6-24  
  Selecting address .....6-14

## I

**ID card copy** .....5-8  
**Input mode** ..... A-8

## K

**Key operation** ..... A-6

## L

**Label** .....3-6  
**Layout tab** .....4-7  
**LDAP server**  
  Registering speed dial .....6-22  
  Searching address .....6-16  
**Letterhead** .....3-7  
**Loading document** .....3-28  
**Loading media** .....3-11  
**Lower Feeder Unit** .....10-3

## M

**Machine Setting menu** ..... 2-22  
**Maintenance** ..... 8-2  
**Media**  
  Clearing misfeeds ..... 9-5  
  Loading ..... 3-11  
  Path ..... 9-5  
  Preventing misfeeds ..... 9-4  
**Media misfeed**  
  ADF ..... 9-19  
  Duplex Option ..... 9-21  
  Interior ..... 9-8  
  Tray 1 ..... 9-15  
  Tray 2 ..... 9-16  
**Media path** ..... 9-5  
**Message window** ..... 2-2  
**Messages**  
  Error messages ..... 9-38  
  Media misfeed messages ..... 9-7  
  Service messages ..... 9-46  
  Status messages ..... 9-37  
**Misfeed problems** ..... 9-23  
  Clearing ..... 9-5  
  Media path ..... 9-5  
  Preventing ..... 9-4

## O

**Original media** ..... 3-26  
  Loading ..... 3-28  
**Output tray** ..... 3-24  
**Overlay tab** ..... 4-7

## P

**Page margins** ..... 3-10  
**Plain paper** ..... 3-3  
**Postcard** ..... 3-7  
**Poster copy** ..... 5-10  
**Print media** ..... 3-2  
  Storage ..... 3-25  
**Print media type**  
  Envelope ..... 3-5  
  Label ..... 3-6  
  Letterhead ..... 3-7  
  Plain paper ..... 3-3

Postcard .....	3-7
Recycled paper .....	3-3
Thick stock .....	3-4
<b>Print quality</b> .....	9-31
<b>Print screen</b> .....	2-13
<b>Printable area</b> .....	3-9
<b>Printer driver</b>	
Basic tab .....	4-6
Displaying .....	4-3
Layout tab .....	4-7
Overlay tab .....	4-7
Quality tab .....	4-7
Setting .....	4-5
Uninstalling .....	4-3
Version tab .....	4-8
Watermark tab .....	4-7

## Q

<b>Quality tab</b> .....	4-7
--------------------------	-----

## R

<b>Recycled paper</b> .....	3-3
<b>Repeat copy</b> .....	5-9
<b>Reporting menu</b> .....	2-50

## S

<b>Scan</b> .....	6-2
Data format .....	6-26
Delete queued transmission job .....	6-29
Resolution .....	6-27
Scan color .....	6-28
Scan density .....	6-27
Scan mode .....	6-27
Scan size .....	6-28
Scan to E-mail .....	6-12
Scan to FTP .....	6-12
Scan to PC .....	6-11
Scan to SMB .....	6-12
Scan to USB Memory .....	6-11
Specify data location .....	6-10
Specify destination address .....	6-12
Subject .....	6-28
<b>Scan Setting menu</b> .....	2-52

## Scanned data destination address

Delete destination address .....	6-19
Edit destination address .....	6-18
Register destination address ....	6-19
Specify destination address .....	6-12
Specify multiple destinations ....	6-18

## Scanner driver

TWAIN driver (Macintosh) .....	6-6
TWAIN driver (Windows) .....	6-3
WIA driver (Windows) .....	6-5

## Select media tray

.....	5-5
-------	-----

## Service messages

.....	9-46
-------	------

## Speed dial

Editing/deleting address .....	6-23
Registering address (direct input) .....	6-21
Registering address (LDAP search) .....	6-22
Selecting address .....	6-13

## Storage

Print media .....	3-25
-------------------	------

## System requirements

.....	1-14
-------	------

## T

### T/C CHANGE

.....	2-15
-------	------

### Thick stock

.....	3-4
-------	-----

### Toner remaining

.....	2-15
-------	------

### Tray 1 Paper Setup menu

.....	2-26
-------	------

### Troubleshooting

Media misfeed .....	9-23
Status, error, and service messages .....	9-37

### TWAIN driver

For Macintosh .....	6-6
For Windows .....	6-3

## U

### USB memory device

.....	6-11
-------	------

### Utility menu

Admin. Management menu .....	2-28
Copy Setting menu .....	2-42
Dial Register menu .....	2-44
FAX RX Operation menu .....	2-47
FAX TX Operation menu .....	2-45
Machine Setting menu .....	2-22



Reporting menu .....	2-50
Scan Setting menu .....	2-52
Tray 1 Paper Setup menu .....	2-26

## V

Version tab .....	4-8
-------------------	-----

## W

Watermark tab .....	4-7
WIA driver .....	6-5

## Z

Zoom ratio .....	5-4
------------------	-----