



VMG1312-B10A / VMG1312-B30A

Wireless N VDSL2 4-ports
Gateway with USB

Firmware V1.00
Edition 1, 11/2013

Quick Start Guide

Default Login Details

| | |
|----------------|--------------------|
| LAN IP Address | http://192.168.1.1 |
| User Name | admin |
| Password | 1234 |

Device Panels

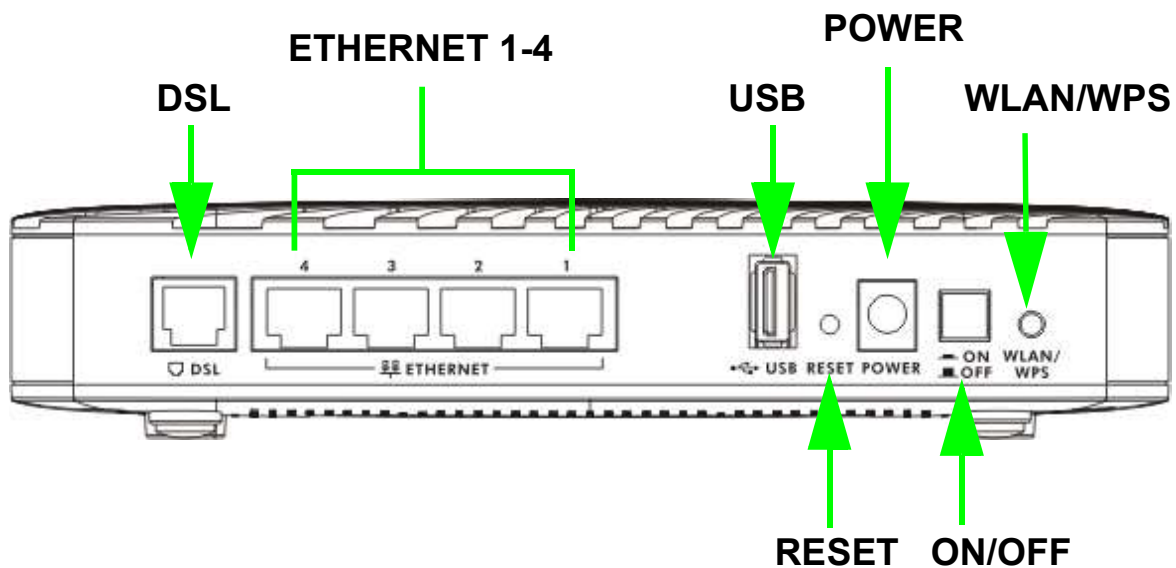
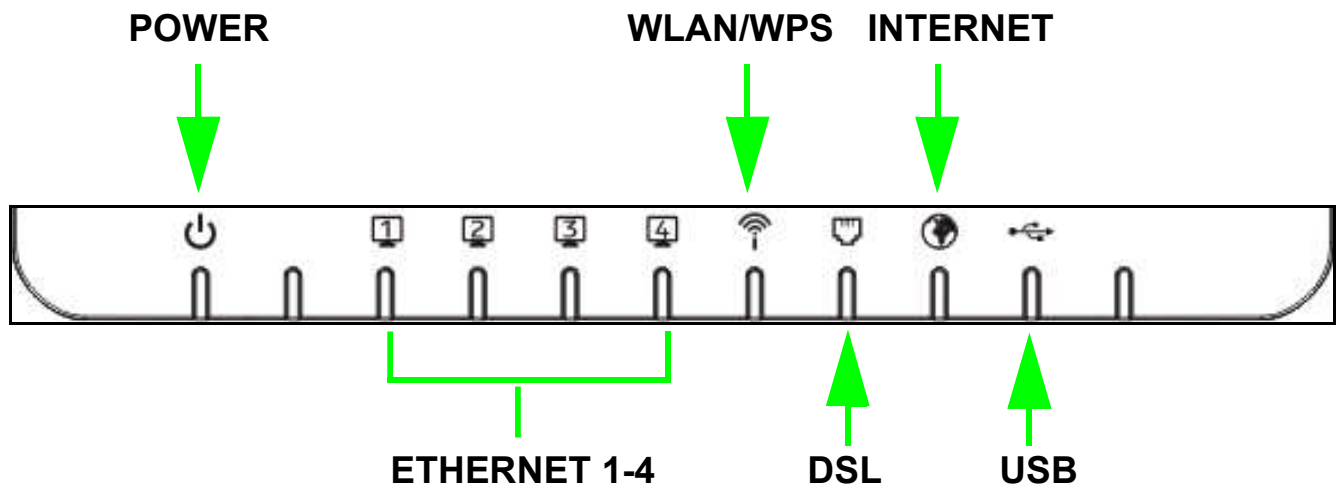

Overview

The Device is a VDSL2 router and Ethernet gateway with a four-port built-in Ethernet switch and IEEE 802.11n wireless. The Device allows wired and wireless clients to safely access the Internet. The built-in firewall blocks unauthorized access to your network. The USB port allows you to connect USB memory stick or USB hard drive for storing or sharing files through the network. Other helpful features include Quality of Service (QoS) which allows time-sensitive services and applications to flow more smoothly.

Requirements

Make sure you have the following things before you start.

- Internet access - account information provided by your ISP, such as user name, password, and so on.
- 3G account - if you want to access the Internet through a 3G network. The Device uses this 3G connection as your WAN or a backup when the DSL connection fails.
- Internet Explorer 6.0 and later versions, with JavaScript enabled, or Mozilla Firefox 3 and later versions or Safari 2.0 and later versions.

Hardware Setup

To connect your Device:

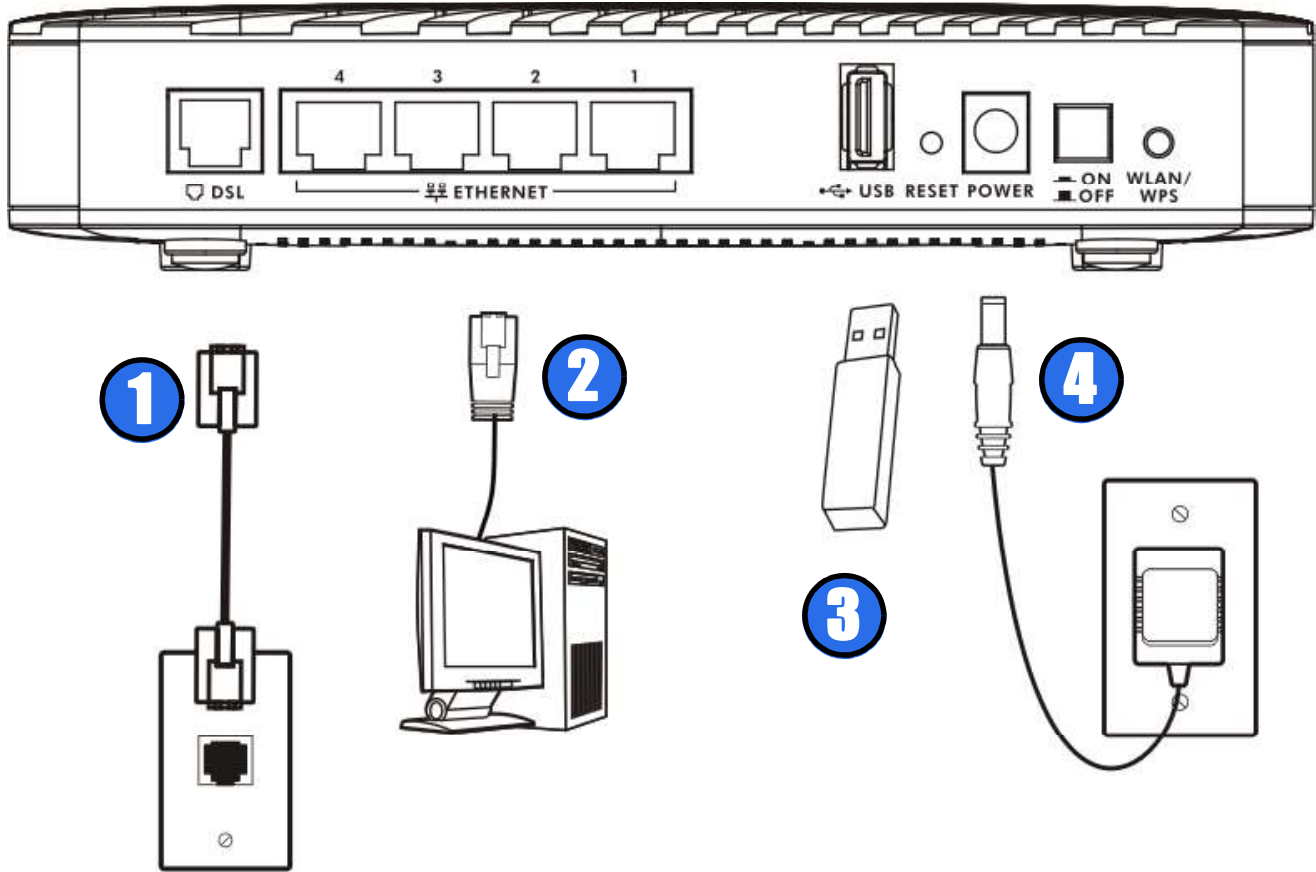

1. Use a telephone cable to connect your Device's **DSL** port to a telephone jack (or the DSL or modem jack on a splitter if you have one).
2. **LAN:** Use an Ethernet cable to connect a computer to a **LAN** port for initial configuration and/or Internet access.
3. **USB:** There is one USB port on your Device. You can do the following:

- a. Connect a USB (version 2.0 or lower) memory stick or a USB hard drive for file sharing. The Device automatically detects the USB device. Alternatively, use a USB cable (not provided) to connect a USB (version 2.0 or lower) printer to this port.
 - b. Insert a 3G adapter to access the Internet wirelessly via a 3G network. The Device uses this 3G WAN connection as a backup when the DSL connection fails.
4. **POWER**: Use the provided power adaptor to connect the **POWER** socket to an appropriate power source. Make sure the power at the outlet is on. After connecting the power adaptor, look at the lights on the front panel.
- The **POWER** light blinks while your Device starts up and then stays on once it is ready.
 - Each **LAN** light stays on if the corresponding **LAN** port is properly connected and blinks when there is traffic.
 - The **USB** light turns on when there is a USB device (printer or memory stick) or a 3G adapter connected to the Device and blinks when transmitting data.
 - The **DSL WAN** light turns on when your Device has a DSL connection.
 - The **WLAN / WPS** light flashes green and orange while WPS is in process. It stays on green when the wireless LAN is ready and blinks when there is traffic.
 - The **INTERNET** light turns on when the gateway is able to access the Internet and will blink when your Device is sending or receiving data.

 *If the lights do not come on, check your connections and inspect your cables for damage. If the lights are still off, contact technical support.*

 *If the WAN light is on but the INTERNET light is off, see the [Tutorials and Broadband](#) chapters in your User's Guide for how to use the **Network Setting > Broadband** screen to set up the WAN connection.*

 If you want to have the Device use 3G as your WAN or as a backup when the Ethernet WAN connection fails, see your User's Guide for how to use the **Network Setting > Broadband > 3G Backup** screen to set up the 3G WAN connection.

Set Up a Wireless Network

You can set up a wireless network using the following methods:

Using Wireless Protected Setup (WPS)

Press the **WPS** button on the Device's back panel for more than 5 seconds to turn the WPS function on.

Follow these steps to add a WPS-enabled device to the wireless network using the **WPS/WLAN** button.

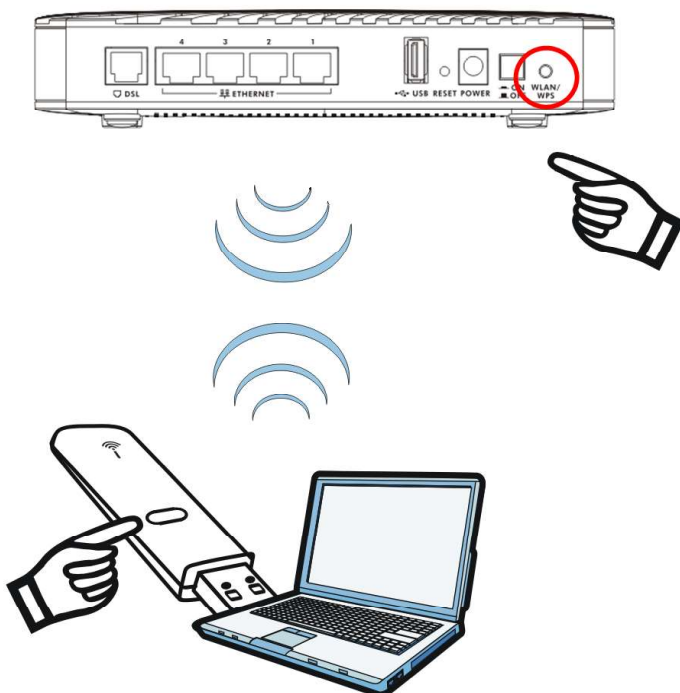

- 1** Place the devices you want to connect near one another.
- 2** Press the WPS button on the Device.
The **WPS** light blinks green and orange
- 3** Press the WPS button on a compatible device within 2 minutes of pressing the button on the Device.
The **WPS** light on the Device shines steadily when connected.

Set Up a Wireless Network Manually

The wireless LAN on your Device is enabled by default. To add a wireless client to the network, use the settings found on the bottom panel of your Device.

Configure wireless devices that you want to connect to the wireless network to use the same wireless settings as the Device.

The default wireless settings vary for each Device. Refer to the bottom panel of your device and use the provided information.

Log into the Web Configurator

Your device may already be set up for Internet access. However, you may want or need to log on to the Device Web Configurator to perform tasks:

- Configure your Internet access settings manually
 - Customize the Quality of Service (QoS) and routing features
 - Create firewall and web filter rules
 - Edit remote management, as well as other features
1. In your browser, if the Device does not automatically re-direct you to the login screen, go to <http://192.168.1.1>.

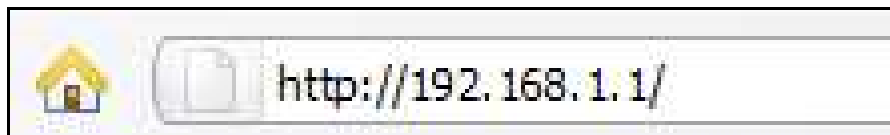

2. Enter the default user name **admin** and password **1234**. Click **Login**.



The image shows the ZyXEL login screen. At the top left is the ZyXEL logo. Below it, the text reads "Welcome" followed by "Welcome to VMG1312-B30A configuration interface. Please enter username and password to login." There are two input fields: "Username:" and "Password:". A "Login" button is located in the bottom right corner.

 *If the login screen does not open, make sure you allow web browser pop-up windows, JavaScripts and Java permissions. Your computer should be also set to get an IP address automatically from a DHCP server. See the appendices in your User's Guide for more information.*

3. In the next screen, you can change the login password. This is recommended. Enter your new password in the **New Password** field. Re-type your new password in the second field and then click **Apply**. If you prefer not to change the password, leave the two fields blank and click **Skip**.

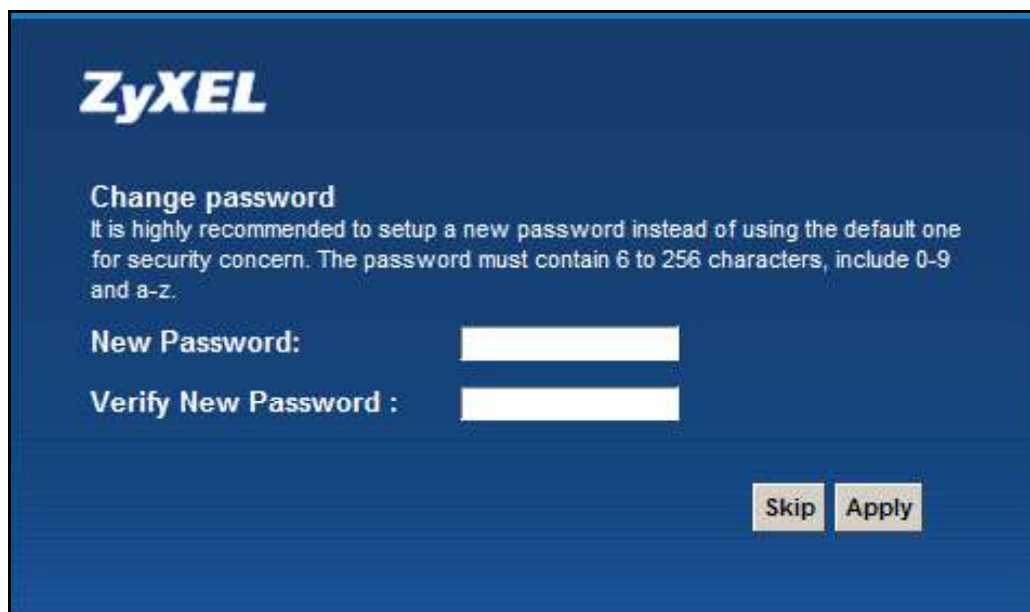

The image shows the ZyXEL "Change password" screen. At the top left is the ZyXEL logo. Below it, the text reads "Change password" followed by "It is highly recommended to setup a new password instead of using the default one for security concern. The password must contain 6 to 256 characters, include 0-9 and a-z." There are two input fields: "New Password:" and "Verify New Password :". At the bottom right, there are two buttons: "Skip" and "Apply".

4. The Quick Start Wizard screen appears. Follow the directions to configure the Device's time zone, Internet access, and wireless settings.

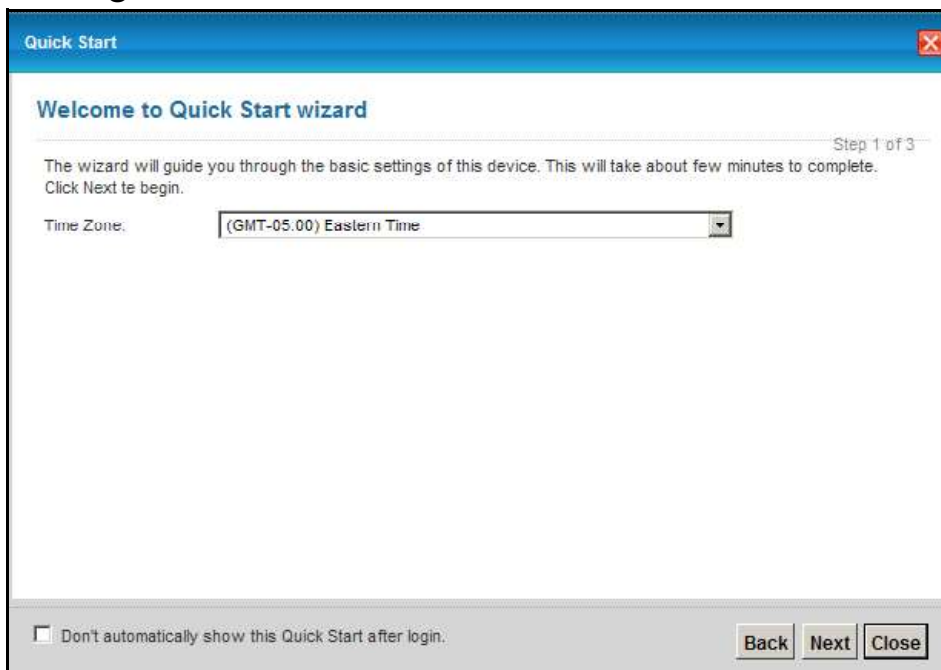

5. The **Network Map** page shows whether the Device and computers/ devices connected to it have Internet access.

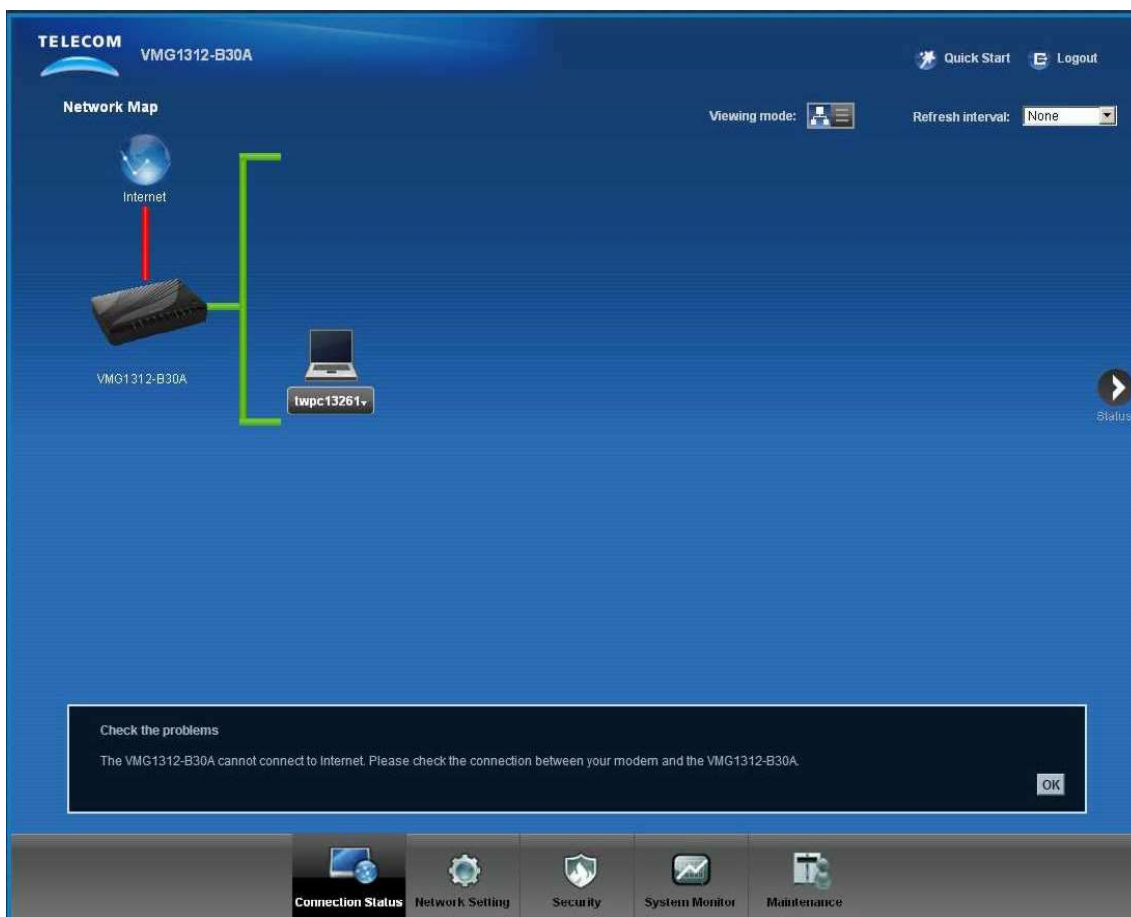

6. Click **Status** to display the following screen, where you can view the Device's device, interface, and system information.

The screenshot displays the 'Status' page for a TELECOM VMG1312-B30A device. The page is divided into several sections:

- Device Information:** Host Name: ZyXEL, Model Number: VMG1312-B30A, Firmware Version: 1.00(AAEB.0)b1_0403.
- WAN Information:** (Empty)
- LAN Information:** - IP Address: 192.168.1.1, - IP Subnet Mask: 255.255.255.0, - DHCP: Server, - MAC Address: CC:5D:4E:AA:50:C4.
- WLAN Information:** - MAC Address: CC:5D:4E:AA:50:C7, - Status: On, - SSID: ZyXEL78bc, - Channel: 1, - Security: No Security, - 802.11 Mode: 802.11b/g/n Mixed, - WPS: Off.
- Security:** - Firewall: Medium.
- System Status:** System Up Time: 0 days: 0 hours: 7 minutes, Current Date/Time: 01 Jan 2012 00:07:14, System Resource: - CPU Usage: 2.99%, - Memory Usage: 73%.

The page also includes a 'Refresh interval' dropdown set to 'None', a 'Quick Start' button, a 'Logout' button, and a 'Refresh interval' dropdown. At the bottom, there is a navigation bar with icons for 'Connection Status', 'Network Setting', 'Security', 'System Monitor', and 'Maintenance'. On the right side, there are buttons for 'Network Map' and 'Virtual Device'.

See your User's Guide for how to use the rest of the Web Configurator screens. You will need to refer to the section on how to setup the **Broadband** connection if the **INTERNET** LED (light) remains off.