

htc

User Guide



HTC U23 pro

Contents

Unboxing and setup

HTC U23 pro overview	6
Inserting nano SIM and microSD cards	7
Unmounting the storage card	9
Charging the battery	10
Turning your phone on and off	10
Setting up your phone for the first time	11
Adding accounts	11
Ways of securing your phone	12
Notification LED	13
Changing your nano SIM card settings	13
Changing the way you navigate your phone	14

Basics

Taking a screenshot	15
Capturing a scrolling screenshot	15
Recording your phone's screen	16
Home screen	17
Lock screen	18
Using Quick Settings	18
Adjusting the volume and sound settings	20
Restarting HTC U23 pro (Soft reset)	20
Accessing your settings	20
Copying, pasting, and sharing text	21
Checking for security updates	21
Checking your system software version	21
Checking for system software updates	22
Displaying a call as a bubble	22

VIVERSE

Getting started with the VIVERSE mobile app	23
AR Messaging	24
Using the VIVE Avatar Creator mobile app	26
Managing crypto assets with VIVE Wallet	27
Using HTC U23 pro with VIVE headsets	27

Taking photos and videos

Quad cameras	29
Getting started with the Camera app	29
Choosing a capture mode	31
Focusing and zooming	32
Taking a photo	33
Scene detection	33
Taking burst shots	34

Bokeh effect	34
Saving selfies as mirrored images	35
Recording video	36
Scanning a QR code	36

More camera features

Taking a panoramic photo	37
Taking an ultra-wide photo	37
Pro mode	38
Adding a watermark to your photo	38
Recording videos in slow motion	38
Recording a time-lapse video	39
Taking a close-up photo	39
Capturing best moments with Top Picks mode	40

Getting the most out of your phone

Tips for extending battery life	41
Freeing up storage space	43
Charging your phone with a wireless charger	44
Charging other devices with your phone	45
Water and dust resistant	45

Transfer

Ways of getting content from your previous phone	48
Transferring files between HTC U23 pro and your computer	48
Transferring files between the internal storage and storage card	49

Backup and reset

Backing up HTC U23 pro	50
Backing up photos and videos	50
Resetting network settings	51
Resetting HTC U23 pro (Hard reset)	51

Internet connections

Connecting to a Wi-Fi network	52
Turning the data connection on or off	53
Turning data roaming on or off	53
Airplane mode	54
Keeping track of your mobile data usage	54
Data Saver	55
Connecting to VPN	55
Installing a digital certificate	56
Using HTC U23 pro as a Wi-Fi hotspot	57
Sharing your Internet connection over USB	57

Apps and notifications

Notifications	58
Managing app notifications	59
App shortcuts	59

Switching between recently opened apps	60
Working with two apps at the same time	60
Using picture-in-picture	61
How do I check whether an app supports picture-in-picture?	61
Turning the location setting on or off	61
Choosing which apps have access to your location	62
Changing an app's permissions	62
Setting default apps	62
Disabling an app	63
Downloading apps from the web	63
Do not disturb mode	63

Wireless sharing

Turning Bluetooth on or off	67
Connecting a Bluetooth headset	67
Unpairing from a Bluetooth device	68
Receiving files using Bluetooth	68
Using NFC	69

Battery settings

Using Battery Saver mode	71
Displaying the battery percentage	71
Checking battery usage	72
Enabling background restriction in apps	72

Security settings

Setting a screen lock	73
Setting up Smart Lock	73
Fingerprint sensor	74
About Face Unlock	75

Display and sound settings

Setting when to turn off the screen	76
Screen brightness	76
Changing the display language	76
Setting app languages	77
Changing the default font size	77
Adjusting the display size	77
Dark theme	78
Night Light	78
Changing your ringtone	78
Changing your notification sound	79
Turning touch sounds and vibration on and off	79
Turning keyboard sound and vibration on or off	79

Trademarks and copyrights

About this guide

We use the following symbols to indicate useful and important information:



This is a note. It provides detailed information for setup, common questions, and what to do in specific situations.



This is a tip. It will give you an alternative way to do a particular step or procedure that you may find helpful.



This indicates important information that you need in order to accomplish a certain task or to get a feature to work properly.



This is a warning. Take note to avoid potential problems or prevent damage to your hardware.

Information contained in this guide may have changed. For the most up-to-date information, including the latest version of this guide, go to [HTC Support](#).

Important note on recoverable data

Files and other data that have been deleted, cleared, removed, or erased from your device may still be recoverable by third-party data recovery software. Even a factory reset may not permanently erase all data from your mobile device, including personal information.

Checking the e-label

To find the e-label, go to Settings and tap **About phone** > **Certificate Information**.

Unboxing and setup

HTC U23 pro overview

After taking HTC U23 pro out of the box, familiarize yourself first with the location of the card tray, controls, and sensors.

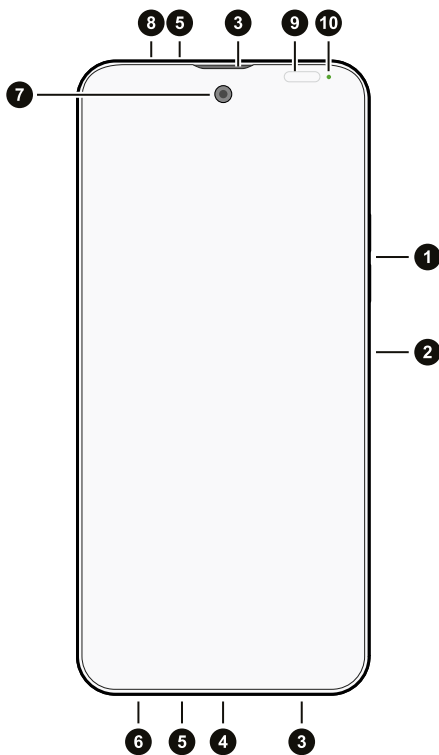

1. Volume control
2. Power button / Fingerprint sensor
3. Speaker
4. USB Type-C® connector
5. Microphones
6. nano SIM and storage card tray
7. Front camera
8. 3.5mm headset jack
9. Proximity and light sensor
10. Notification LED

You need a 5G NR/4G LTE™ plan to use your operator's 5G NR/4G LTE network for voice calls and data services. Check with your operator for details.

Dual SIM supports both 5G NR and 4G LTE SIM cards. Only one card can use 5G NR at a time.



- If you want to use a case or screen protector, don't cover and block the proximity and light sensor. Purchase a case or screen protector designed for HTC U23 pro.
- Don't disassemble any part of the phone. Don't try to open the phone or remove the battery by force. This may damage the phone or its electronics and will invalidate the warranty.

Back panel

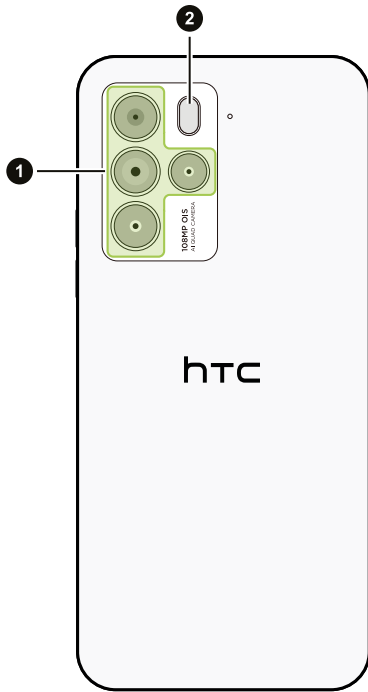

1. Quad cameras
2. LED flash

Inserting nano SIM and microSD cards



- Use a standard nano SIM only. Don't cut a larger SIM card to fit. It's thicker than a standard nano SIM card and may get stuck in the slot.
- The microSD™ card is optional and sold separately.
- If you're using your old microSD card, make sure you have backups of your content on a computer or cloud storage before inserting the card. You may be prompted to format the card.

1. Hold the phone face up.
2. Insert and push the tip of the tray eject tool that came in the box (or a small bent paperclip) into the tray eject hole until the tray ejects, and then pull the tray out.

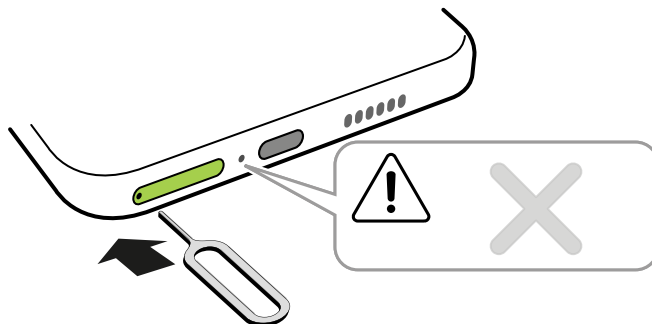

3. With the gold contacts facing up, place your main nano SIM card on the top side of the tray. Make sure to align the cut-off corner of the card to the notch in the holder.

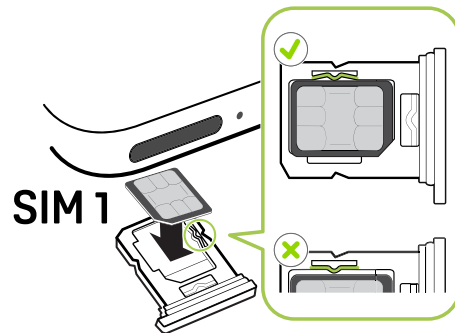

When inserting the nano SIM card, press the card against the tab in the tray to fix it in place.

4. Flip the tray over to the bottom side, and then place either your second nano SIM card or a microSD card with the gold contacts facing up.

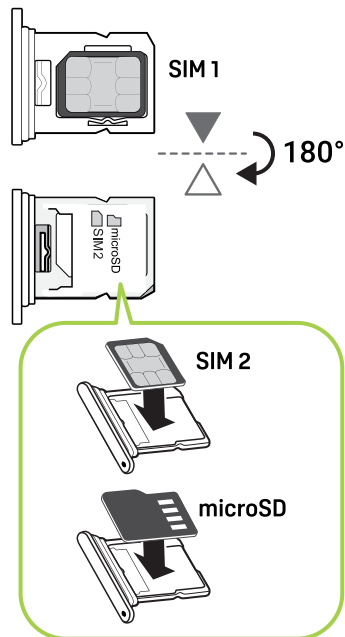

When inserting the nano SIM or microSD card, press the card against the tab in the tray to fix it in place.

5. With the top side of the tray facing up, insert the tray back into the slot.

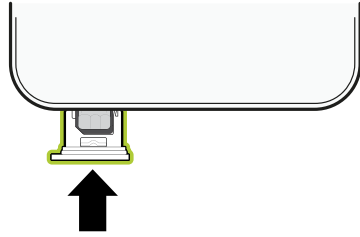

6. Make sure the tray is flush with the side of the phone.

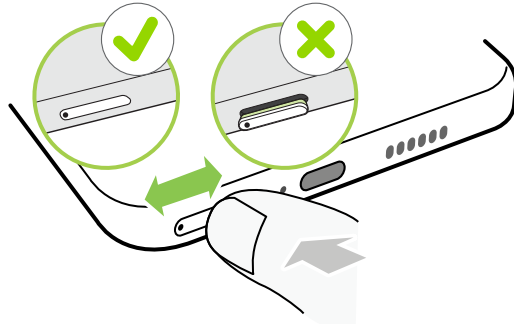

- You need a 5G NR/4G LTE plan to use your operator's 5G NR/4G LTE network for voice calls and data services. Check with your operator for details.
- Dual SIM supports both 5G NR and 4G LTE SIM cards. Only one card can use 5G NR at a time.
- You can choose the preferred card to use for your mobile data connection. To find out how, see [Changing your nano SIM card settings](#) on page 13.

Follow the same procedure above to pull the tray out and remove your cards. Before pulling out the tray, make sure to unmount your microSD card first. See [Unmounting the storage card](#) on page 9.

Unmounting the storage card

When you need to remove the storage card while HTC U23 pro is on, unmount the storage card first to prevent corrupting or damaging the files in the storage card.

1. From the Home screen, tap **Settings** > **Storage**.
2. On the Storage screen, tap ▼ , and then select your storage card.
3. On the top-right corner of the screen, tap ⋮ > **Eject**.

Charging the battery

Before you turn on and start using HTC U23 pro, it is recommended that you charge the battery.



- If the battery has been fully drained, you may need to charge HTC U23 pro for several minutes before powering it on.
- Use HTC's power adapter and USB Type-C cable to charge the battery. When the battery power is too low, make sure to use the power adapter to charge, not a USB cable connection with your computer.

1. Insert the small end of the USB Type-C cable into the USB Type-C connector.

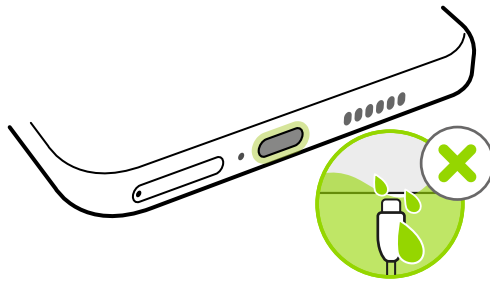

2. Insert the other end of the USB Type-C cable into the power adapter.
3. Plug in the power adapter to an electrical outlet to start charging the battery.
4. After you finish charging, unplug the USB cable from your phone first. Hold the part of the power adapter that's close to the USB port when you unplug the adapter from the outlet.



- Avoid charging the battery in hot environments. As a safety precaution, the battery may stop charging to avoid overheating.
- When you're using battery-intensive apps such as games or video streaming apps while charging the battery, your phone may become warmer. This is normal.
- It is strongly recommended to unplug the power adapter from the electrical outlet when not in use.

Turning your phone on and off

When you turn on your phone for the first time, you'll need to set it up.

Turning your phone on

Press and hold the Power button until the phone vibrates.

Turning your phone off

1. If the display is off, press the Power button to turn it back on.
2. Press and hold the Power button until the options menu opens.
3. Tap **Power off**.

Setting up your phone for the first time

When you switch on HTC U23 pro for the first time—or after you’ve done a factory reset—you’ll need to set up the phone.



Before you start, back up your photos, videos, and data to your Google® Account so you can import them to HTC U23 pro.

During the setup, you’ll be prompted to do the following:

- Choose the system language to use, read and agree to the terms of use, and choose your internet connection.
- Choose where to copy or restore data from.
- Sign into your Google Account.
- Turn on the various Google services. Make sure the **Back up to Google Drive** option is turned on to enable Auto Backup.

It’s also recommended to enable Location and Device maintenance services.

- Set up Google Assistant™. For details, visit support.google.com/assistant/.
- Set up device protection for your phone. For details, see [Security settings](#) on page 73.

To install app updates and finish the phone setup, swipe down from the top of the screen to open the Notifications panel, and then tap the **Android Setup** notification. Follow the onscreen instructions to complete the setup.

Adding accounts

Add your accounts to access them on HTC U23 pro. You can add several Google Accounts and sync contacts, email, calendar, and Google app data from these accounts to HTC U23 pro.

1. From the Home screen, tap **Settings > Passwords & accounts**.
2. Tap **Add account**.
3. Tap the account type you want to add.
4. Follow the onscreen instructions to enter your account information.

Syncing your accounts

1. From the Home screen, tap **Settings > Passwords & accounts**.
2. Turn on **Automatically sync app data** to enable automatic sync of all your accounts.
3. To manually sync individual accounts, select an account, tap **Account sync**, and then tap **⋮ > Sync now**.



In a Google Account, you can choose which apps to turn sync on or off.

Removing an account

Remove accounts from HTC U23 pro if you no longer use them. Removing an account does not remove accounts and information from the online service itself.

1. From the Home screen, tap **Settings > Passwords & accounts**.
2. Tap an account.
3. Tap **Remove Account**.



Some personal data may be retained by the third-party app after you have removed the account from HTC U23 pro.

Ways of securing your phone

It's important to set your phone to lock automatically to prevent others from accessing your files and information in case it gets lost or stolen. Here are ways that can help secure your phone:

- **Screen lock:** Secure your phone with a PIN, password, or pattern. See [Setting a screen lock](#) on page 73.
- **Fingerprint:** Add your fingerprint and use it for waking up and unlocking your phone. See [Fingerprint sensor](#) on page 74.
- **Face Unlock:** Set your phone to unlock using your registered face when you're on the lock screen. See [About Face Unlock](#) on page 75.
- **Smart Lock:** Set your phone to automatically unlock when it's safe with you, such as when your phone is in your pocket or you're at home. See [Setting up Smart Lock](#) on page 73.

Notification LED

When the phone is on and plugged in to a power source, the notification LED shows different colors based on the charging level.

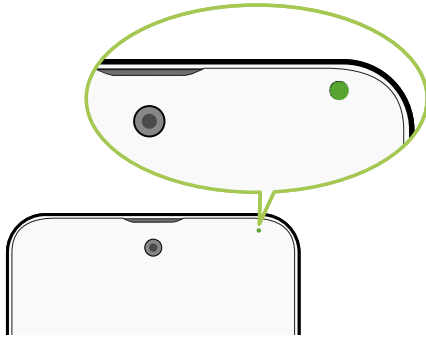

LED color	Status
Green	Fully charged
Red	Charging



The phone will also show the above LED colors when it's placed on a wireless charger.

Additionally:

- While running on battery, the LED will flash red when the battery drops to 15% or below.
- Your notifications always take priority. Regardless of charging or battery status, the LED will flash green when you have a pending notification.

Changing your nano SIM card settings

When you have two nano SIM cards inserted on your phone, there are several options you can set for your cards.

1. From the Home screen, tap **Settings** > **Network & internet**.
2. Tap **SIMs**.
3. Tap a SIM card. Here are some of the settings you can change for the selected SIM card:
 - Change the SIM card name.
 - Enable or disable the SIM card.
 - Set the SIM card as the default card for your mobile data connection.
 - Set the SIM card as the default card for making phone calls.
 - Set the SIM card as the default card for sending SMS messages.

Changing the way you navigate your phone

By default, you navigate your phone using the Navigation bar at the bottom of the screen. You can change the way to navigate your phone.



1. From the Home screen, tap **Settings > System**.
2. Tap **Gestures > System navigation**.
3. Select one of the following types of navigation:

- **Gesture navigation**

Use swipe gestures to go back to the previous screen, return to the Home screen, and access recent apps.

You can tap , and then adjust **Back sensitivity**.

- If you set **Back sensitivity** to **Low**, you'll need to swipe from the leftmost or rightmost edge of the screen to perform the back gesture.
- If you set it to **High**, you'll be able to swipe a bit away from the edge of the screen.
- **3-button navigation**

This is the default Navigation bar with the Back , Home , and Recent apps  buttons.





There's a tutorial that plays back when you select a type of navigation. View the tutorial to learn how to navigate.

Basics

Taking a screenshot

Want to show off your high game score? It's easy to take a picture of an app screen and share it.

1. Go to the app screen that you want to capture.
2. Press and hold Power and Volume down at the same time.
A thumbnail of your screenshot will be displayed at the bottom left.
3. Do any of the following:
 - To share the screenshot, tap  and choose how you want to share it.
 - To edit the screenshot, tap the thumbnail or tap .



Capturing a scrolling screenshot

Capture that long message thread, webpage, or article as one screenshot.

1. Go to the screen that you want to capture.
2. Press and hold Power and Volume down at the same time.
3. At the bottom next to the screenshot thumbnail, tap **Capture more**.

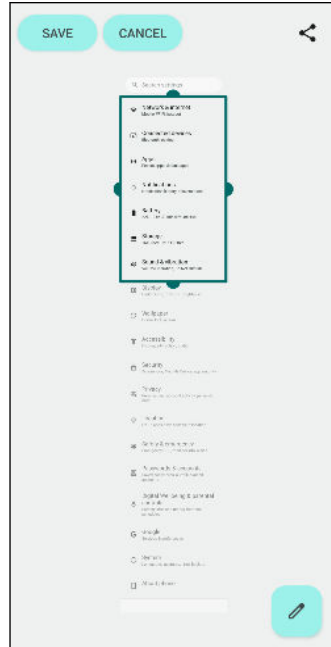
- Adjust the crop box to select the content you want to capture.



- Do any of the following:
 - Tap  to add text or drawings on the screenshot.
 - Tap **Save** to save the screenshot.
 - Tap  to share the screenshot.

Recording your phone's screen

You can record a video of what you're doing on your phone—for example, your gameplay or a walk-through on how to use an app.

- Go to the screen where you want to start recording.
- From the top of the screen, swipe down twice to open Quick Settings.
- Find and tap **Screen record**.

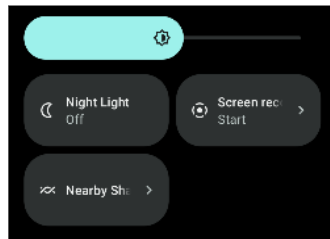

4. Choose what you want to include in the recording and tap **Start**.

The status bar will display a timer icon for three seconds, then your phone will start recording.

5. To stop recording, swipe down from the top of the screen, and then tap **Stop** on the Screen Recorder notification.



Swipe down again from the top of the screen to open the Notifications panel. Then tap the Screen Recorder notification to view the recorded video. You can also share the video.

Home screen

You can customize the Home screen to suit your needs.

From the main Home screen, you can do the following:

Option	Steps
Change the home and lock screen wallpaper	<p>Press and hold the Home screen, then select Wallpapers.</p> <p>You can also go to Settings > Wallpaper, and then tap Wallpaper & style.</p>
Add widgets	Press and hold the Home screen, then select Widgets .
Add apps	Press and hold an app on the Apps screen, then drag it to the Home screen.
Group apps into folders	<ol style="list-style-type: none"> 1. On the Home screen, press and hold an app, then drag it over to another app. A folder will be created. 2. Tap Edit name and enter a folder name. 3. Drag more apps to the folder. 4. Tap outside the folder to close it.
Enable automatic Home screen rotation	<ol style="list-style-type: none"> 1. Press and hold the Home screen, then select Home settings. 2. Turn on Allow Home screen rotation.
Add or remove a Home screen panel	<p>A new Home screen panel will be added when you drag an app or widget to the right edge of the rightmost Home screen panel.</p> <p>After you move all apps and widgets out from a Home screen panel, the empty Home screen panel will be deleted automatically.</p>

Lock screen

Here's what you can do on the Lock screen:

- Swipe up on the lock screen to unlock the screen.



Make sure to set up a screen lock to help protect your phone. See [Setting a screen lock](#) on page 73.

- Tap twice on a notification to go directly to the related app.
- Swipe left or right on the notification to dismiss it.



- Go to **Settings > Display > Lock screen** and choose what information you want to show or hide on the lock screen.

To hide lock screen notifications completely, tap **Privacy**, and then select **Don't show notifications at all**.

- To set more lock screen notification options, go to **Settings > Notifications > Notifications on lock screen**.

Using Quick Settings



In the Quick Settings panel, easily turn settings such as Wi-Fi® and Bluetooth® on or off.

1. To open the Quick Settings panel, do any of the following:

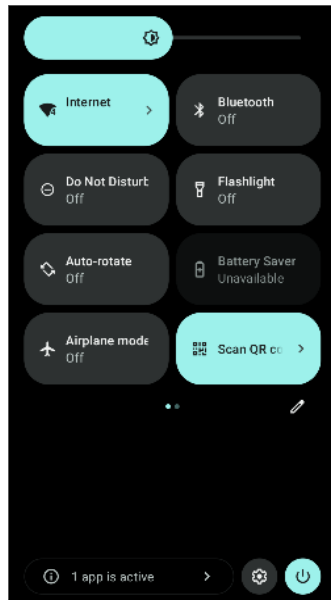
Method	Step
Method 1	From the lock screen, swipe down from the top of the screen.
Method 2	Swipe down with two fingers from the top of the screen.
Method 3	Swipe down with one finger from the top of the screen to display the first few settings. Then swipe down again to display the full Quick Settings panel.



2. Swipe left or right to see more tiles.
3. In the Quick Settings panel, you can do the following:



Option	Steps
Adjust screen brightness	Drag the brightness slider.
Turn a setting or feature on or off	Tap the tile of a setting or feature.
Customize a setting	Press and hold the tile of the setting you want to change.
Start screen recording	Tap Screen record .
Choose and arrange tiles	<ol style="list-style-type: none"> 1. Tap . 2. Do any of the following: <ul style="list-style-type: none"> ▪ Press and hold a tile, and then drag it to your desired position. ▪ Scroll down to the bottom of the Quick Settings panel. Then from the Hold and drag to add tiles section, drag a tile up to add it to the Quick Settings panel. ▪ Press and hold a tile you want to remove from the Quick Settings panel, then drag it down to the Hold and drag to add tiles section. 3. When done, press .

Adjusting the volume and sound settings

Pressing the Volume up and Volume down buttons changes the volume of whatever sound is playing right now. If no sound is playing, it adjusts the media volume. Pressing the buttons also displays the volume control.

Here's how to turn on or off different types of sound and adjust their volume:



- Tap  to switch the ringer and notifications between vibrate, silent, and normal.
- Drag the media  slider to adjust the media volume.
Drag the slider all the way down to mute the media volume.
- Tap  to adjust different types of volume.
Tap **Settings** to access Sound & vibration settings.



To make your phone vibrate when there are incoming calls, turn on **Ring vibration** in Vibration & haptics settings.

Restarting HTC U23 pro (Soft reset)

If HTC U23 pro is running slower than normal, is unresponsive, or has an app that is not running properly, try restarting and see if that helps solve the problem.

1. If the display is off, press the Power button to turn it back on.
2. Press and hold the Power button, and then tap **Restart**.

If your phone does not respond when you touch the screen or press the buttons, you can still restart it. Press and hold the Power button until your phone vibrates, and then release the button.



You may need to press and hold the Power button for 15 seconds before the phone vibrates.

Accessing your settings

There are several ways you can find and access settings on your phone.

1. Open Settings from the Home screen, Apps screen, or Notifications panel:
 - On the main Home screen, tap **Settings**.
 - From the Home screen, swipe up, and then find and tap **Settings**.
 - Swipe down with two fingers from the top of the screen, and then tap .
2. Tap the search bar to enter an option or setting you want to find.

Copying, pasting, and sharing text

Here's how to select, copy, paste, and share text:

1. Press and hold on a word.
2. Drag the start and end anchors to highlight the text you want to select.
3. After you've selected the text, do any of the following:
 - Tap **Copy**. Press and hold on the text entry field where you want to paste the text, then tap **Paste**.
 - Tap **Share**, and then select the app or sharing method you want to use.

Checking for security updates

When there's a security patch that provides security fixes or enhancements available for download, you'll receive a security update notification. You can easily install the update from the notification.

You can also manually check for security updates in Settings.

1. From the Home screen, tap **Settings** > **Security**.
2. Do the following:
 - Tap **Security update** > **Check for update**.
 - Tap **Google Play system update** > **Check for update**.



Just like security updates, Google Play™ system updates also provide important security and privacy fixes or enhancements. You may be able to get these updates faster since they are sent directly to your phone from Google Play™, just like app updates.

Checking your system software version

Before installing a system software update, you can check first what Android™ version you have on your HTC device.

1. On the Home screen, tap **Settings**.
2. Tap **About phone**.
3. Check under Android version.

Checking for system software updates

You'll receive a notification if there's a system software update available for your phone model. You can also manually check for system software updates in Settings.

1. On the Home screen, tap **Settings**.
2. Tap **System** > **Software updates**.
3. Tap **Check now**.

Displaying a call as a bubble

During a call, you can minimize the screen to a floating bubble. This makes it easier for you to multitask.

- In the ongoing call, press ● . The bubble appears on the Home screen.
- Drag the bubble to change its position. You can only move it along the left or right edges of the Home screen.
- Press the bubble to display options.

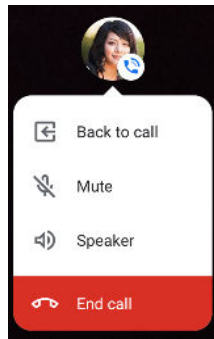

- To display the call in full screen again, do any of the following:
 - Press the bubble, and then tap **Back to call**.
 - Slide open the Notifications panel, and then tap the **Ongoing call** notification.
- To remove the bubble, drag it down to the **Hide** option at the bottom of the Home screen.

VIVERSE

Getting started with the VIVERSE mobile app

The VIVERSE platform connects individuals and communities together in the metaverse, allowing you to create your avatars, explore virtual worlds, and socialize from any device. With the VIVERSE mobile app, you can do all these right from your phone.



You can download the latest app version from Google Play Store.

If this is your first time to use the VIVERSE app, here's how to get started:

1. On your phone, open **VIVERSE**.
2. Tap **Sign in** and sign in to VIVERSE using one of the following methods:

Method	Description
WalletConnect	Sign in using a WalletConnect-compatible wallet such as VIVE Wallet. Note: If this is your first time to sign in to the VIVERSE platform using your wallet, a new HTC account will be created.
HTC Account	Sign in using your existing HTC account. Tip: If you don't have an HTC account, tap Create New Account to create one using your email address or phone number.



If you chose a standard avatar on the Welcome to VIVERSE screen and didn't sign in, you can still use the VIVERSE app as a guest user, but the selected avatar will not be saved to your HTC account.

3. Tap **Account > My Avatars** and do any of the following:
 - If you have existing avatars, select an avatar, and then tap **Set as active** to use it as your avatar in VIVERSE.
 - To create a virtual character as your avatar, tap **Create avatar**, choose a base model to start with, and follow the onscreen instructions to customize and save your avatar.



- You can also use VIVE Avatar Creator to create a more realistic avatar. For details, see [Using the VIVE Avatar Creator mobile app](#) on page 26.
- To find out about other ways of creating avatars, visit the [VIVERSE Avatar](#) website.

4. Tap the tabs at the bottom to use various VIVERSE services.

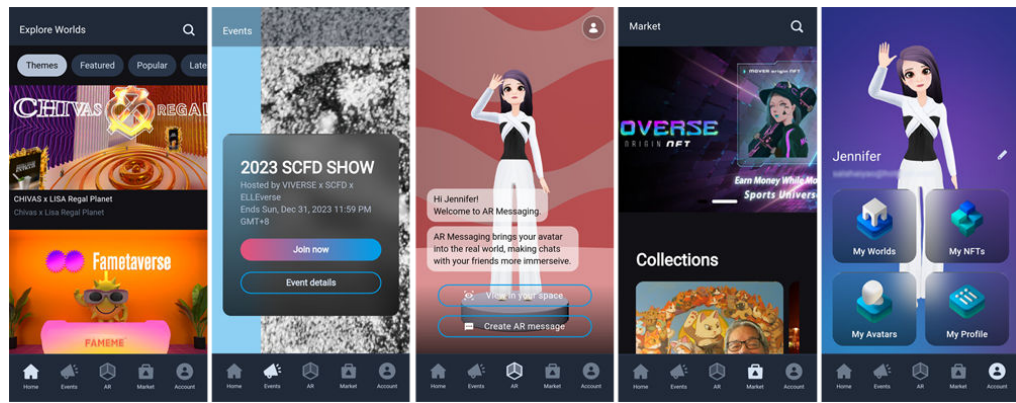

Tab	Description
Explorer	Explore the diverse worlds within VIVERSE, including exciting collaborations and exhibitions with partners.
Events	For details, see the World Help and FAQs in the VIVERSE Help Center.
AR	Say hi to your friends in a fun and unique way! Use our AR service to send customized and lively messages with your own avatar. A one-of-a-kind social experience that your friends will love. For details, see AR Messaging on page 24.
Market	Choose from our curated NFT collections created by renowned artists, brands, and creators worldwide. Buy yourself pieces of unique digital collectibles, World environments, and designer virtual clothing for your avatar. For details, see the Market Help and FAQs in the VIVERSE Help Center.
Account	View your created worlds, change your display name, create and switch between your avatars, check your purchases on Market, and more.

AR Messaging



With the VIVERSE app's AR Messaging feature, you can share your avatar as a photo, video, or AR message that appears in a real environment. Here's how:

1. On your phone, open **VIVERSE**.
2. Tap the **AR** tab.

3. To change to another avatar, tap  in the upper right and select an avatar.
4. Do any of the following:



- **Share your avatar as a photo or video:**

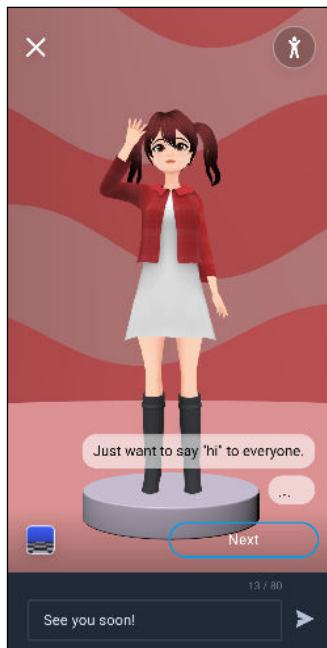

1. Tap **View in your space**. Your avatar will appear in your space.
2. To move your avatar, tap at the area where you want to place your avatar.
3. Tap  in the upper right and select an avatar gesture—such as a waving or dancing gesture.
4. Use the onscreen controls to capture a photo or video recording of your avatar in your environment.
5. Tap  and then choose how you want to share the photo or video.

- **Share the link to your AR message:**



1. Tap **Create AR message**.
2. Enter your text message.
3. Tap  in the upper right and select an avatar gesture—such as a waving or dancing gesture.
4. Tap **Next**.
5. Tap  and then choose how you want to share the link.



- After the recipient opens the link on their phone, they'll be able to see your AR message in their space when they tap **View in your space**.
- After the recipient opens the link on their computer and clicks **View in your space**, a QR code will be displayed. They'll be prompted to use their phone's camera and scan the QR code to view the AR message.

Using the VIVE Avatar Creator mobile app

You can use VIVE Avatar Creator to create realistic avatars. Create up to 15 avatars and choose one as your active avatar in VIVERSE.

Here's how to create avatars using VIVE Avatar Creator:

1. On your phone, open **VIVE Avatar**.
2. Sign in with your HTC account.
3. Follow the onscreen instructions to create and customize an avatar. You can take a selfie or use an existing one to create your avatar.

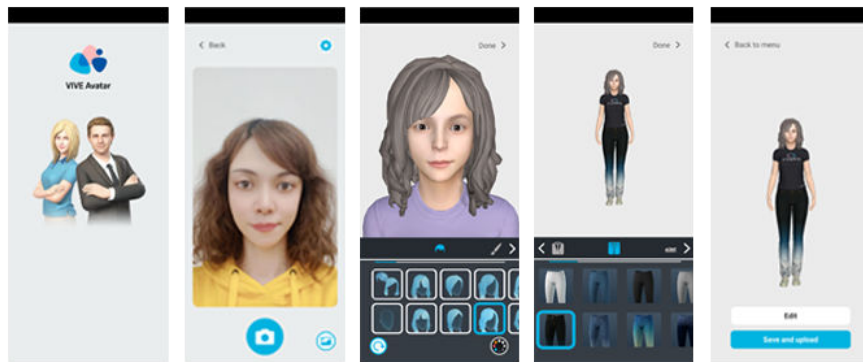

4. When you're done, tap **Save and upload**. Your avatar will be uploaded to VIVERSE.
5. When upload is complete, tap **OK**.
6. In the **Set as active** dialog box, tap **Yes** to use the avatar you've uploaded as your default avatar in VIVERSE apps and services.



After you've finished uploading a new avatar, tap **Back to menu**. You can do any of the following:

- Tap **Create avatar** to create and upload a new avatar.
- Tap **⋮** and choose whether to edit an avatar, delete it, or set it as your active avatar.
- If you have an avatar that was created using an old version of the VIVE Avatar Creator app, you may be prompted to reupload it. Tap **⋮** > **Edit** and make your changes, then tap **Save and upload**.

Managing crypto assets with VIVE Wallet

Use VIVE Wallet to manage your cryptocurrencies and collectibles right from your phone.

Here are some of the things you can do with VIVE Wallet:

- Create a new wallet or import your existing wallet.
- View, send, and receive cryptocurrency and tokens, and check your transaction history.
- Change priority settings to speed up or cancel transactions.
- View, send, and receive NFTs.

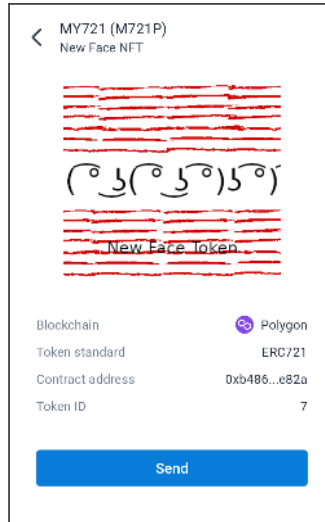

- Connect to your wallet from NFT marketplaces to purchase NFTs.
- Connect to your wallet from DApps via WalletConnect.

For more details, open VIVE Wallet on your phone, go to Settings, and then tap **Help**.

Using HTC U23 pro with VIVE headsets

You can use HTC U23 pro as a companion phone for VIVE™ standalone headsets.

The following apps on HTC U23 pro allow you to easily set up and manage headsets:

Mobile app	Compatible headsets	App features
VIVE Manager app	<ul style="list-style-type: none"> ▪ VIVE XR Elite ▪ VIVE Focus 3 	<ul style="list-style-type: none"> ▪ Quickly set up the headset. ▪ Change basic headset settings. ▪ Cast the headset to your phone (VIVE XR Elite and VIVE Focus 3). ▪ Install system updates on the headset. ▪ Set up Kiosk mode (VIVE XR Elite only). ▪ Use your phone as the controller (VIVE Flow only).

Mobile app	Compatible headsets	App features
VIVE app	VIVE Flow	▪ And more...

For details, visit the following support pages:

- [VIVE XR Elite Support](#)
- [VIVE Flow Support](#)
- [VIVE Focus 3 Support](#)

Taking photos and videos

Quad cameras

HTC U23 pro gives you imaging at its finest. With four rear-mounted cameras, take stunning shots from a variety of perspectives.

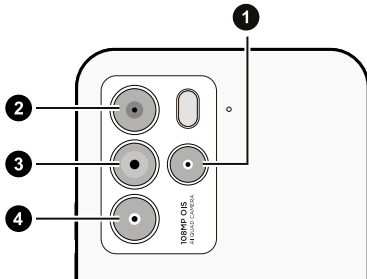

1. 5MP macro camera

Take macro shots at the closest focal distance of 4 cm (1.6 in). See [Taking a close-up photo](#) on page 39.

2. 8MP ultra-wide camera

Take ultra-wide photos with the 120-degree camera. See [Taking an ultra-wide photo](#) on page 37.

3. 108MP f/1.7 camera

Capture high-resolution photos at 108MP. See [Taking a photo](#) on page 33.

4. 2MP depth-sensing camera

Capture professional-looking portraits with blurred background. See [Bokeh effect](#) on page 34.

Getting started with the Camera app

Take great photos and videos with HTC U23 pro.

For your convenience, there's more than one way to launch the Camera app.

- On the Home screen, tap the camera icon to open the **Camera** app.
- Press the Power button twice.



Make sure **Quickly open camera** is turned on in **Settings > System > Gestures**.

By default, **Photo** mode is selected the first time you use the Camera app. The following controls are available in **Photo** mode:



Control	Description
	Switch between the front and rear cameras.
	Take a photo.
	View the last photo or video taken.
	Choose a zoom ratio. See Focusing and zooming on page 32.
	Apply facial touch-ups when taking photos.
	Turn the flash on or off.
	Set High Dynamic Range (HDR) to auto, on, or off.
	Turn scene detection on and off.
	Access Google Lens.
	Turn Top Picks mode on and off.
	Access camera settings.

Choosing a capture mode

Switch to a capture mode to use for taking photos or videos.

1. To scroll through the capture modes, swipe left or right above the shutter release button in portrait orientation—or swipe up or down in landscape orientation.

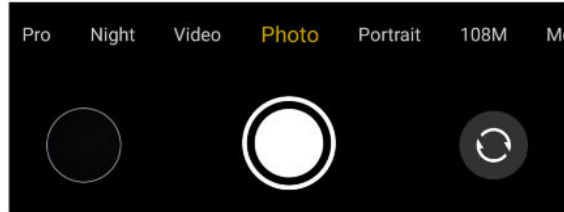

2. Tap the capture mode you want to use.



To choose from more capture modes, tap **More**.

Focusing and zooming

Before taking a photo or video, adjust the focus, exposure, and zoom ratio.



These settings may not be available in certain capture modes.

Focus and exposure

In capture modes such as **Photo** and **Video** modes, the camera automatically focuses when you point the camera at your subject.

You can also do the following:

- Auto focus on another subject. Just tap the subject.
- Auto adjust exposure. Tap a dark area to brighten it, or tap an overexposed area to darken it.
- Manually adjust exposure. Tap the screen, and then drag your finger up or down to increase or decrease exposure.



Zoom ratio

In capture modes that support zooming, do any of the following:

- On the Viewfinder screen, slide two fingers apart to zoom in or together to zoom out. You can also freely zoom in or out while recording video.
- Tap the button that shows the zoom ratio you want to use such as $1\times$ or $2\times$.
- Tap the $1\times$ or $2\times$ button until a zoom bar appears, and then drag the slider to gradually increase or decrease the zoom ratio.



This will change the $2\times$ button to the zoom ratio that you've set.



Taking a photo

Take captivating, high-quality photos with the main camera.

1. On the Home screen, tap the camera icon to open the **Camera** app.
2. Choose one of the following capture modes for taking photos:

Mode	Description
Photo	Take photos at various resolutions. To choose a resolution, tap  > Picture size .
Portrait	Take photos with blurred background. See Bokeh effect on page 34.
108M	Take photos at the highest 108MP resolution.
Night	Take photos in low-light conditions. This mode captures at a fixed 12MP resolution.

3. Tap the buttons at the top of the Viewfinder screen in portrait orientation—or on the left side of the screen in landscape orientation—to change capture settings.



Not all capture settings in **Photo** mode are available in **108M** mode.









4. Point the camera at your subject. The camera will focus automatically as you move it.
5. Adjust the focus, exposure, and zoom ratio. See [Focusing and zooming](#) on page 32.
6. When you're ready to take the photo, tap .







Scene detection

In **Photo** mode, scene detection automatically sets the scene for your subject.

1. On the Home screen, tap the camera icon to open the **Camera** app.
2. Switch to **Photo** mode, if you're not in this mode. See [Choosing a capture mode](#) on page 31 for details.
3. Tap  to turn scene detection on.
4. Point the main camera at your subject.

Depending on the type of subject you're capturing, you may see one of these icons:

Icon	Scene mode	Icon	Scene mode
	Food		Portrait
	Building		Pet
	Flower		Plant
	Beach		Snow

Icon	Scene mode	Icon	Scene mode
	Blue sky		HDR
	Sunrise / Sunset		Car
	Fruit		Autumn
	Document		

- When you're ready to take the photo, tap .

Taking burst shots

Do you want to take photos of moving subjects? Whether it's your kid's football game or a car race, you can capture the action.

- On the Home screen, tap the camera icon to open the **Camera** app.
- Switch to **Photo** mode, if you're not in this mode. See [Choosing a capture mode](#) on page 31 for details.
- Press and hold .

While shooting, you'll see the number of consecutive shots captured. Release the button to stop capturing.

Bokeh effect

In **Portrait** mode, you can take portrait shots and selfies with a soft blurred background. Bokeh light spots that appear in the background or on the subject can also be changed into different shapes such as heart, butterfly, or star shapes.



- To get a nice blurred background when taking portrait shots, keep a distance of 0.5-1.5m (2-5 ft) between your phone and your subject.
- You need to be in a well-lit environment.
- Some features such as HDR, zooming, and flash are not available in **Portrait** mode.

- On the Home screen, tap the camera icon to open the **Camera** app.
- Switch to **Portrait** mode. See [Choosing a capture mode](#) on page 31.
- Tap  to switch between the front and main cameras.

4. To change bokeh light spots into a certain shape, tap  and then select a shape you want to use. Drag the slider to adjust the blur level.

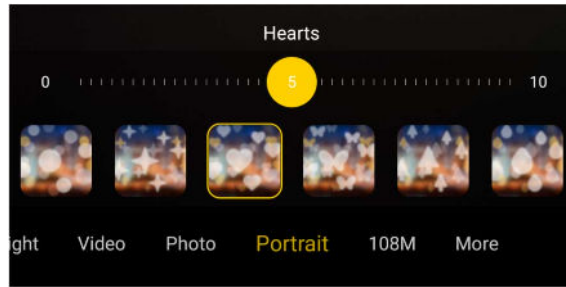



5. Point the main camera at your subject, or pose at the front camera if you're taking a selfie.
6. When you're ready to take the photo, tap .

Here are some examples of bokeh shots:



Saving selfies as mirrored images



When you view yourself on the Viewfinder screen, your selfie is actually a mirrored image. Here's what to do if your captured photo looks flipped and is not the mirrored image.

1. Switch to **Photo**, **Portrait**, or **Night** mode. To find out how, see [Choosing a capture mode](#) on page 31.
2. Tap  to switch to the front camera.
3. Tap  and make sure **Mirrored selfies** is turned on.
4. Take your selfie shots.

Your selfies will be saved as mirrored images.





Recording video

Capture videos of memorable moments.

1. On the Home screen, tap the camera icon to open the **Camera** app.
2. Switch to **Video** mode. See [Choosing a capture mode](#) on page 31 for details.
3. Tap  to switch between the front and main cameras.
4. Adjust the focus, exposure, and zoom ratio. See [Focusing and zooming](#) on page 32.
5. To start recording, tap .



While recording video, you can still change the focus, exposure, and zoom ratio. You can also turn the flash on and off while recording video with the main camera.

6. Tap  to capture a still shot while recording video.
7. Tap  to pause the recording, and then tap  to resume.
8. To stop recording, tap .

Scanning a QR code

Use the main camera to scan a QR code and extract the information stored in it.

1. On the Home screen, tap the camera icon to open the **Camera** app.
2. Switch to **Photo** mode. See [Choosing a capture mode](#) on page 31 for details.
3. Tap  and make sure **QR code recognition** is turned on.
4. Point the camera at the QR code you want to scan.

The information from the QR code will be displayed on the screen.

5. Tap the button at the bottom of the screen to access the displayed information.

For example, if the information is a URL, tap the **Go to URL** button to open the URL in your web browser.

More camera features

Taking a panoramic photo

Get a wider shot of landscapes in one sweep with **Panorama** mode.



1. On the Home screen, tap the camera icon to open the **Camera** app.
2. Switch to **Panorama** mode. See [Choosing a capture mode](#) on page 31 for details.
3. Hold your phone in portrait orientation and point the camera at the scene you want to capture.
4. When ready, tap  and then slowly move your phone in the direction indicated by the arrow on the screen.

Hold your phone as steadily as you can to avoid distortion while the camera captures frame by frame.

5. Finish panning, or tap  to stop capturing.
When done capturing, the camera stitches the frames into a single photo.
6. Tap **X** to exit **Panorama** mode.

Taking an ultra-wide photo

HTC U23 pro has a dedicated ultra-wide camera that can cover up to an angle of 120 degrees when capturing photos. Here's how to take an ultra-wide photo:

1. On the Home screen, tap the camera icon to open the **Camera** app.
2. Switch to **Photo** mode. See [Choosing a capture mode](#) on page 31 for details.
3. Tap  to use the ultra-wide angle camera.
4. Point the camera at the scene you want to capture.
5. When ready, tap .





By default, **Correct lens distortion** is enabled which removes distorted edges from ultra-wide shots. When you need to take photos with fish-eye effects, tap  and then turn off this setting.

Pro mode

Use **Pro** mode to manually adjust settings such as ISO, exposure and white balance and capture professional-quality photos.

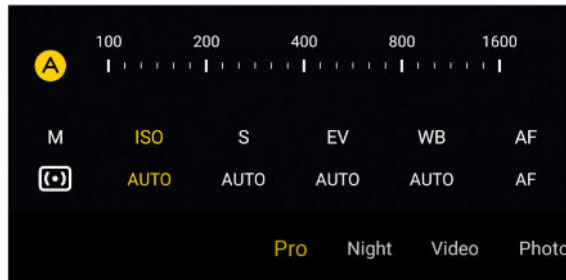

1. On the Home screen, tap the camera icon to open the **Camera** app.
2. Switch to **Pro** mode. See [Choosing a capture mode](#) on page 31 for details.
3. Tap a setting, and then adjust the slider that appears or choose from the displayed options.



4. Point the camera at your subject. The camera focuses automatically as you move your phone.
5. When you're ready to take the photo, tap .

Adding a watermark to your photo

Add the date and time, preset text, or your phone model on your captured photo.

1. On the Home screen, tap the camera icon to open the **Camera** app.
2. Tap  > **Watermark**.
3. Choose the watermarks you want to add to your photos.
4. Point the camera at your subject. The camera focuses automatically as you move your phone.
5. Adjust the focus, exposure, and zoom ratio. See [Focusing and zooming](#) on page 32.
6. When you're ready to take the photo, tap .





Recording videos in slow motion

Add a touch of suspense by recording actions in slow motion.



Audio is recorded in this mode, but will only be available when video is played back in normal speed.

1. On the Home screen, tap the camera icon to open the **Camera** app.
2. Switch to **Slow Motion** mode. See [Choosing a capture mode](#) on page 31 for details.
3. To start recording, tap .



4. Tap  to pause the recording, and then tap  to resume.
5. To stop recording, tap .
6. Tap  to exit **Slow Motion** mode.

Recording a time-lapse video

Use **Time-lapse** mode to capture slow changing scenes or actions—such as clouds moving through the sky or construction of a building—as fast moving videos.

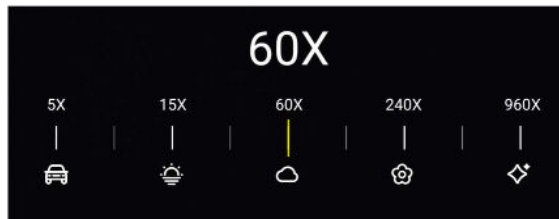
1. On the Home screen, tap the camera icon to open the **Camera** app.
2. Switch to **Time-lapse** mode. See [Choosing a capture mode](#) on page 31 for details.
3. Tap  and select a playback speed for your time-lapse recording. You can choose from speeds between **5X** and **960X**.



4. When you're ready to start recording, tap .
5. While recording, you can do the following:
 - Change focus to a different subject or area by tapping it on the Viewfinder screen.
 - Tap the flash button to turn the flash on or off.
6. To stop recording, tap .
7. Tap  to exit **Time-lapse** mode.



Taking a close-up photo

Use **Macro** mode to take photos of objects or pets at close range.

1. On the Home screen, tap the camera icon to open the **Camera** app.
2. Switch to **Macro** mode. See [Choosing a capture mode](#) on page 31 for details.
3. Point the camera at your subject.





To get a clear close-up shot, keep a distance of 4 cm (1.6 in) between your phone and your subject.

4. Keep your phone steady. When you're ready to take the photo, tap .
5. Tap  to exit **Macro** mode.

Capturing best moments with Top Picks mode

Get more than just a still photo. Capture living moments as motion photos in JPG format. Top Picks mode starts capturing a few seconds before you tap the shutter release button, and automatically picks shots with the best image quality.

Top Picks mode helps pick out your best shots—people smiling with their eyes open. It can also analyze and recommend your best jump shots.

1. On the Home screen, tap the camera icon to open the **Camera** app.
2. Switch to **Photo** mode. See [Choosing a capture mode](#) on page 31 for details.
3. Tap  to turn on Top Picks mode.
4. Point the camera at your subject. The camera focuses automatically as you move your phone.
5. Adjust the focus, exposure, and zoom ratio. See [Focusing and zooming](#) on page 32.
6. Keep your phone steady. When you're ready, tap .



Use Google Photos™ to view recommended shots and choose which ones to save.

Getting the most out of your phone

Tips for extending battery life

How long the battery can last before it needs recharging depends on how you use HTC U23 pro. Try out some of these tips to help increase battery life.

Use the power management features

- Turn **Battery Saver** on in Settings. See [Using Battery Saver mode](#) on page 71.
- Monitoring your battery usage helps identify what's using the most power so you can choose what to do about it. For details, see [Checking battery usage](#) on page 72.

Manage your connections

- Turn off wireless connections such as mobile data, Wi-Fi, or Bluetooth when not in use.
- Turn on Airplane mode when you don't need any wireless connections and you don't want to receive calls or messages.

Manage your display

Lowering the brightness, letting the display sleep when not in use, and keeping the Home screen simple helps save battery power.

- Lower the screen brightness when you don't need it. See [Screen brightness](#) on page 76.
- Set the screen timeout to a shorter time. See [Setting when to turn off the screen](#) on page 76.
- Don't use a live wallpaper for your Home screen. Animation effects are nice to show off to other people but they drain your battery.

Changing your wallpaper to a plain, black background can also help a little. The less color is displayed, the less battery is used.

Manage your apps

- Restrict battery usage of apps running in the background. See [Enabling background restriction in apps](#) on page 72.
- Install the latest software and application updates. Updates sometimes include battery performance improvements.

- Uninstall or disable apps that you never use.

Many apps run processes or sync data in the background even when you're not using them. If there are apps that you don't need anymore, uninstall them.

If an app came preloaded and can't be uninstalled, disabling the app can still prevent it from continuously running or syncing data. See [Disabling an app](#) on page 63.

- Allowing apps to always get your location will drain the battery. You can set apps to access your location only when you're using them. See [Choosing which apps have access to your location](#) on page 62.

When you're running low on battery, turn off the location setting temporarily. See [Turning the location setting on or off](#) on page 61.

Limit background data and sync

Background data and sync can use a lot of battery power if you have many apps syncing data in the background. It's recommended not to let apps sync data too often. Determine which apps can be set with longer sync times, or sync manually.

- In Settings, tap **Passwords & accounts** and check what types of data are being synced in your online accounts. When the battery is starting to run low, temporarily disable syncing some data.
- If you have many email accounts, consider prolonging the sync time of some accounts.
- When you're not traveling from one place to another, sync weather updates of only your current location, rather than in all of your named cities. Open the Weather app, and then tap  to edit and remove unneeded cities.
- Choose widgets wisely.

Some widgets constantly sync data. Consider removing the ones that are not important from your Home screen.

- In Google Play Store, tap your profile icon and select **Settings** in the menu. Then tap **Network preferences > Auto-update apps** and select **Don't auto-update apps** if you're fine with updating apps from Google Play Store manually.

Other tips

To squeeze in a little bit more battery power, try these:

- Tone down the ringtone and media volume.
- Minimize the use of vibration or sound feedback. In Settings, tap **Sound & vibration** and choose which ones you don't need and can disable.
- Check your apps' settings as you may find more options to optimize the battery.

Freeing up storage space

As you use HTC U23 pro, you'll gradually fill up the storage with content over time. Here are some tips on how to free up phone storage space.

Manage photos and videos

- After taking burst shots, keep only the best shot.
- After editing a photo or trimming a video, the original file is kept. Delete original files or move them elsewhere, such as to your computer.
- If you're only sending videos through MMS, use a lower resolution. Hi-res video takes up more space.
- Turn on **Storage manager** to help handle old photos and videos on your phone.

Back up data and files

Keep only the most recent app data or files that you often need to use. Back up your other data or files.

Remove or disable apps

Uninstall apps that you've downloaded if you no longer need them.

Preinstalled apps can be disabled when you're not using them.

Manually free up space

On the Storage screen, tap **Free up space**. The phone checks the phone storage and suggests items you can delete.

Charging your phone with a wireless charger

HTC U23 pro has wireless charging capability. You can charge your phone's battery with a wireless charger (sold separately).

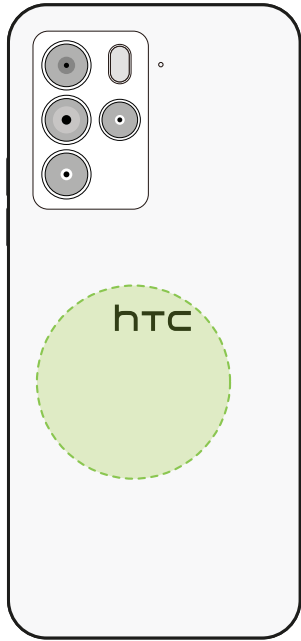

The wireless charging coil is located on the center of the back panel. Connect your wireless charger to a power source, and then place the center of your phone's back panel on top of the wireless charger.

To check whether the battery is being charged, do any of the following:

- Check whether the phone's notification LED shows solid red.
- Check for the battery charging icon in the status bar.
- Go to Settings, tap **Battery**, and check if **Charging wirelessly** is displayed.



Wireless charging may be slower than charging the phone with a USB cable. This is normal.

Wireless charging precautions

When using a wireless charger, take note of the following precautions to properly charge the battery and avoid potential issues or damage to your phone.

- Wireless charging may be unstable or may not work when your phone is not in complete contact with the charger. If you're using a protective case, it is recommended to remove the case before placing your phone on the wireless charger.
- Do not place cards with magnetic strips or radio-frequency identification (RFID) chips—such as credit cards, ATM cards, key cards, and transportation cards—on or near the wireless charger while charging. Cards may get damaged.
- Do not leave your phone and wireless charger unattended while charging.

Charging other devices with your phone

You can use HTC U23 pro as a charger for other devices that support the Qi wireless standard. To use this feature, you need to enable wireless reverse charging on your phone.

1. On the Home screen, tap **Settings**.
2. Tap **Battery**.
3. Turn on **Wireless reverse charging**.
4. Place the device you want to charge on the center of your phone, with their backs facing one another.



- Wireless reverse charging uses low power for charging. Charging speed or efficiency may vary between different devices.
- When your phone's battery level drops below 30%, it will stop charging the other device. Wireless reverse charging will also be disabled automatically.

When you've finished charging, remove the other device from your phone.

Water and dust resistant

HTC U23 pro is water and dust resistant. It has an IP67 rating as defined in the International Standard IEC 60529. With the nano SIM/microSD slot covered and closed tightly, the phone is water resistant if it is briefly submerged by accident in fresh water less than 1 meter deep and no longer than 30 minutes at room temperature.

HTC U23 pro must not be exposed to non-fresh water, high water pressure, strong or fast-moving water, or sand since these may cause overheating, electric shock, or damage to the phone. Do not attempt to charge or otherwise use the USB port when HTC U23 pro is wet. Normal wear and tear may decrease the water and dust resistance over time.

Warranty will be void if the phone is not used in accordance with the instructions and precautions addressed in this user guide, including, but not limited to, using the phone in environments or situations that exceed the limitations of the IP67 rating. For usage precautions and tips on care and maintenance, see [Care and maintenance tips](#) on page 45 and [Cleaning and drying](#) on page 47. Also make sure to read the Safety guide that comes with the phone.

Care and maintenance tips

Follow these tips and precautions to help maintain water and dust resistance for your phone.

Never attempt to insert or remove the nano SIM and microSD cards with gloves, wet hands, or when the phone is wet.



- Before inserting the tray and closing the card slot, wipe off every drop of water or dirt with a clean, dry cloth. Also make sure that no hairs, fibers, or small particles are caught between the tray and the slot opening to prevent water from entering the phone.
- Parts that maintain water resistance such as the tray—which acts as the card slot cover—may degrade over time. If these parts degrade or get damaged, the phone will no longer be water resistant. If this happens, contact your retail store or mobile operator. You may be charged for parts replacement.

Do not intentionally submerge your phone. If the phone accidentally gets immersed in water, avoid pressing the controls—such as the Power and Volume buttons—and do not operate the phone.

Do not expose the phone to fast or strong-moving water such as shower spray, running taps or faucets, waterfalls, or ocean waves.

Do not expose the phone to or let the USB port come in contact with the following:

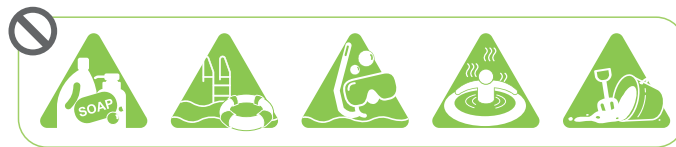

- Water containing soap, detergent, or shower gel
- Sea water, swimming pools, spas, hot water, and hot springs
- Any liquid besides tap water such as alcohol, juices, and condiments
- Sand

If the phone is exposed to fresh water, make sure to dry it thoroughly. To avoid damaging the phone, do not charge when contaminants are present or the USB port is not completely dry. In these circumstances, do not connect any external device.

Never use a hair dryer to dry wet parts of the phone.

The power adapter and accessories are not water resistant. Never use them in wet areas such as in the bathroom or kitchen since contact with water may cause malfunction, electric shock, or other hazards.

Avoid leaving the phone in humid places such as the bathroom or kitchen for too long since it is not moisture-proof.

Cleaning and drying

If HTC U23 pro has had contact with salt water, liquid chemicals, dust, or other contaminants, immediately rinse the phone. When the phone is wet, make sure to dry it thoroughly.



- To avoid damaging HTC U23 pro, do not charge the phone when contaminants are present or the USB port is not completely dry. In these circumstances, do not connect any external device.
- The sound volume of the earpiece, speakers, and microphone may be less audible if these parts are not completely dry.

Rinsing

1. Before rinsing, make sure the nano SIM/microSD slot is covered and closed tightly.
2. Rinse the phone using fresh water. Rinse by hand only. Don't use a brush or sponge.

While rinsing, do not press on the tray to avoid having gaps around the card slot which may allow water to enter the phone.

Drying

1. Gently wipe off the water from the phone with a clean, dry cloth. Don't use cotton swabs to wipe the earpiece, speakers, microphone, and connection port.
2. The display may not respond accurately to touch gestures when it's wet. For the touch screen and lenses, wipe with a soft dry cloth such as a microfiber cloth that will not scratch the surface.
3. Leave the phone at room temperature for 3 hours or so to let it dry completely. If buttons and any connection port such as the USB port are still wet, make sure to let them dry completely before you use the phone.

If condensation forms inside the display such as when there's a drastic change in temperature, place the phone at room temperature until condensation disappears.

Transfer

Ways of getting content from your previous phone

Depending on the operating system on your old phone, use one of the following methods to transfer content to HTC U23 pro:

From an Android phone

Back up your old phone to your Google Account first. When you set up HTC U23 pro for the first time, sign in to your Google Account and restore your old phone's data to HTC U23 pro.

From an iPhone

Download and install the Google Drive™ app on your iPhone, and use it to back up iPhone content to your Google Account. When you set up HTC U23 pro for the first time, sign in to your Google Account and restore your old phone's data to HTC U23 pro.

Transferring files between HTC U23 pro and your computer

You can transfer photos, videos, and other files between HTC U23 pro and your computer.



Save and close your files before copying them from your computer to HTC U23 pro, or vice versa.

1. Connect HTC U23 pro to the computer using your USB Type-C cable.
2. On HTC U23 pro, unlock the screen if it's locked.
3. Slide the Notifications panel open. Tap **Charging this device via USB** twice, and then do the following:
 - Under the **USB controlled by** section, select **This device**.
 - Under the **Use USB for** section, select **File Transfer**.
4. Open a file management app such as File Explorer on your computer, and then click **HTC U23 pro**.

Then double-click **Internal shared storage** or your storage card.

5. Copy files from your computer to HTC U23 pro, or vice versa.
6. After copying your files, disconnect HTC U23 pro from the computer.



You can also use cloud storage services to put your media in one place so you can manage them anywhere—on your computer, HTC U23 pro, and other mobile devices.

Transferring files between the internal storage and storage card

If you're using your storage card as removable storage, you can transfer files between the internal storage and your storage card. You can also transfer files to or from an external USB storage device when you have it connected to your phone.

1. From the Home screen, tap **Settings > Storage**.
2. Do one of the following:
 - To transfer files from the internal storage, select **This device** from the dropdown menu. Then tap the type of file you want to transfer.
 - To transfer files from your storage card (or external drive), select the storage card name (or **USB drive**) from the dropdown menu. Then tap **Files**.
3. When you're prompted to choose an app to use, select the **Files** app.
4. Navigate to the folder that contains the files you want to transfer.
5. To select or deselect files, do any of the following:
 - Press and hold a file to select it. To select more files, tap each file.
 - Tap a file to deselect it.
 - To select all files, tap **⋮ > Select all**.
6. Tap **⋮**, and then tap **Copy to** or **Move to**.
7. Tap **≡** to open the slideout menu, and then choose where you want to copy or move your files.
8. Tap **Copy** or **Move**.



To transfer files between your phone and a Mac computer, use a file transfer tool such as Android File Transfer. Visit android.com/filetransfer/ for more information.

Backup and reset

Backing up HTC U23 pro

Back up HTC U23 pro to your Google Account so you can restore content such as app data and settings to the same phone (after a factory reset) or another phone.

1. From the Home screen, tap **Settings > System > Backup**.
2. If you have more than one Google Account, tap **Account storage**, and then select the account you want to use.
3. Make sure **Backup by Google One** is turned on.
4. Tap **Back up now**.



Your phone will back up automatically over Wi-Fi after it's been idle and charging for two hours.

Backing up photos and videos

Use Google Photos to back up your photos and videos to your Google Account.



The help content here is based on the following app version: 6.18.x.

Turning on backup

When you turn on backup, Google Photos automatically backs up camera shots to your Google Account—whether they're stored in internal storage or your storage card.

1. Open the Google Photos app.
2. Do one of the following:
 - If this is your first time opening Google Photos, tap **Turn on Backup**, and then follow the onscreen instructions.
 - Turn on backup in Google Photos settings:
 1. Tap your profile photo on the top-right corner of the screen.
 2. Tap **Photos settings > Backup**.
 3. Turn on **Backup**.

Backing up media folders

Here's how to back up other folders such as Downloads or Screenshots and media folders you created.

1. Open the Google Photos app.
2. Tap your profile photo on the top-right corner of the screen.
3. Tap **Photos settings** > **Backup** > **Back up device folders**.
4. Choose the folders you want to back up to your Google Account.

Resetting network settings

Reset the network settings when you're having problems connecting HTC U23 pro to the Internet or Bluetooth devices.

1. From the Home screen, tap **Settings** > **System** > **Reset options**.
2. Tap **Reset Wi-Fi, mobile & Bluetooth**.
3. Tap **Reset settings**.
4. Tap **Reset settings** again.

Resetting HTC U23 pro (Hard reset)

If HTC U23 pro has a persistent problem that cannot be solved, you can perform a factory reset (also called a hard reset or master reset). A factory reset reverts HTC U23 pro back to its initial state—the state before you turned it on for the first time.



Apps you've downloaded and installed, your accounts, your files, as well as system and app data and settings will be removed. Be sure to back up any data and files you want to keep before you do a factory reset.

1. From the Home screen, tap **Settings** > **System** > **Reset options**.
2. Tap **Erase all data (factory reset)**.
3. Tap **Erase all data**.
4. Tap **Erase all data** again.



A factory reset may not permanently erase all data, including personal information.

Internet connections

Connecting to a Wi-Fi network



HTC U23 pro can connect to 2.4 GHz and 5 GHz Wi-Fi networks.

HTC U23 pro also supports the Wi-Fi 6E standard. You can connect your phone to 6 GHz wireless networks in regions where the phone is certified to use Wi-Fi 6E.



Currently, HTC U23 pro can only use Wi-Fi 6E in select regions. Because Wi-Fi 6E is still a new standard, availability and channels will be dependent on local legislation in your country.

1. From the Home screen, tap **Settings** > **Network & internet**.
2. Tap **Internet**, and then tap the **Wi-Fi On/Off** switch to turn it on.
3. Tap a Wi-Fi network you want to connect to.
4. If you selected a secured network, enter the network key or password.
5. Tap **Connect**.

The Wi-Fi network setting will be saved. The Wi-Fi icon (, , or ) will be displayed in the status bar.



- The number shown on the Wi-Fi icon indicates whether you've connected to a 2.4 GHz, 5 GHz, or 6 GHz network.
- You can save several Wi-Fi network connections. To switch to a different Wi-Fi network, tap **Saved networks** on the Wi-Fi screen and then select the network you want to connect to.
- When you don't need to use Wi-Fi, open the Quick Settings panel and turn Wi-Fi off to save battery life. See [Using Quick Settings](#) on page 18.

In what regions can Wi-Fi 6E be used?

Currently, HTC U23 pro can connect to Wi-Fi 6E networks in the following regions:

- Australia
- Belgium
- Canada
- Czech Republic
- Denmark
- France
- Germany
- Hong Kong
- Ireland
- Israel
- Japan
- Kingdom of Saudi Arabia
- Korea
- Netherlands
- New Zealand
- Poland
- Spain
- Sweden
- Switzerland
- United Arab Emirates
- United Kingdom
- United States

Turning the data connection on or off

Turning your data connection off when not in use saves battery life and money on data charges.



- You need a 5G NR/4G LTE plan to use your operator's 5G NR/4G LTE network for voice calls and data services. Check with your operator for details.
- Dual SIM supports both 5G NR and 4G LTE SIM cards. Only one card can use 5G NR at a time.

1. Open the full Quick Settings panel. See [Using Quick Settings](#) on page 18.
2. Tap the **Internet** tile to turn the data connection on and off.



If you do not see the **Internet** tile on the Quick Settings panel, swipe left to see more tiles.



If you don't have the data connection turned on and you're also not connected to a Wi-Fi network, you won't receive automatic updates to your email, social network accounts, and other synced information.

Turning data roaming on or off

Connect to your mobile operator's partner networks and access data services when you're out of your mobile operator's coverage area.



Using data services while roaming may be costly. Check with your mobile operator for data roaming rates before you use data roaming.

1. On the Home screen, tap **Settings**.
2. Tap **Network & internet** > **SIMs**.

3. If you have two SIM cards inserted, tap the SIM card you want to set.
4. Tap the **Roaming On/Off** switch to turn it on or off.

Airplane mode

When you enable Airplane (Flight) mode, all wireless radios on HTC U23 pro are turned off, including the call function, data services, Bluetooth, and Wi-Fi.

When you disable Airplane mode, the call function is turned back on and the previous state of Bluetooth and Wi-Fi is restored.



- You can manually turn Bluetooth and Wi-Fi back on after enabling Airplane mode.
- If Wi-Fi hotspot and Bluetooth tethering are turned on, enabling Airplane mode turns them off. You need to manually turn them back on after you disable Airplane mode.

Do any of the following to turn Airplane mode on or off:

- In **Settings > Network & internet**, tap the Airplane mode **On/Off** switch to turn Airplane mode on or off.
- With two fingers, swipe down from the status bar to open the Quick Settings panel. Tap the **Airplane mode** tile to turn airplane mode on or off.

When enabled, the Airplane mode icon  is displayed in the status bar.

Keeping track of your mobile data usage

If you're on a limited data allowance, it's important to keep track of the activities and apps that use mobile data.



Data usage measured by the system may be lower than your actual data usage.

1. From the Home screen, tap **Settings > Network & internet**.
2. Tap **SIMs**.
3. If you have two SIM cards inserted, choose the SIM card you use for your data connection.
4. Make sure **Mobile data** is turned on.
5. Do any of the following:
 - Tap **App data usage** to check the overall app data usage to date. Tap an app to see more details on its data usage.
 - Tap **Data warning & limit** to configure the following:

Option	Steps
Data warning	Turn on Set data warning . Then tap Data warning to set how much data is used before you get alerts.

Option	Steps
Data limit	Turn on Set data limit . Then tap Data limit to set how much data is used before your data connection automatically turns off.



When setting a data warning or data limit, tap ▼ to change the unit to megabytes (MB) or gigabytes (GB).

Data Saver

Data Saver helps you limit cellular data costs by restricting background data usage. You can also set applications to always have access to a data connection—such as your email app—to be ignored by Data Saver.

1. From the Home screen, tap **Settings** > **Network & internet**.
2. Tap **Data Saver** and then tap the **On/Off** switch to turn it on or off.
3. Tap **Unrestricted data**, and then tap the **On/Off** switch next to those apps that you want to still have access to data connection even if Data Saver is turned on.

Connecting to VPN

Add virtual private networks (VPNs) so you can connect and access resources inside a local network, such as your corporate or home network.

Before you can connect HTC U23 pro to your local network, you may be asked to:

- Install security certificates.
- Enter your login credentials.
- Download and install a required VPN app, such as for connecting to a secured enterprise network. Contact your network administrator or VPN provider for details.

Also, HTC U23 pro must first establish an Internet connection before you can start a VPN connection.

Adding a VPN connection



You must first set a lock screen PIN, password, or pattern before you can use credential storage and set up the VPN.

1. On the Home screen, tap **Settings**.
2. Tap **Network & internet** > **VPN**, and then tap **+**.
3. Enter the VPN settings and set them up according to the security details your network administrator gave you.
4. Tap **Save**.

Connecting to a VPN

1. On the Home screen, tap **Settings**.
2. Tap **Network & internet > VPN**.
3. Tap the VPN that you want to connect to.
4. Enter your log in credentials, and then tap **Connect**. When you're connected, the VPN connected icon  appears in the notification area of the status bar.

To disconnect from a VPN connection, tap the VPN connection, and then tap **Disconnect**.

You can then open the web browser to access resources such as your corporate network intranet.

Installing a digital certificate

Use client and Certificate Authority (CA) digital certificates to enable HTC U23 pro to access VPN or secured Wi-Fi networks, and also to provide authentication to online secure servers. You can get a certificate from your system administrator or download it from sites that require authentication.



- You must set a lock screen PIN or password before installing a digital certificate.
- Some apps such as your browser or email client let you install certificates directly in the app. See the app's help for details.

1. Save the certificate file in the root folder on HTC U23 pro or your storage card.
2. From the Home screen, tap **Settings > Security**.
3. Tap **More security settings > Encryption & credentials > Install a certificate**.
4. Choose the type of certificate you want to install.

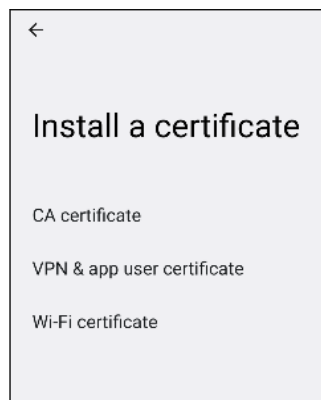

5. Tap the menu button , and then tap where you saved the certificate.
6. Tap the certificate file and enter a name.
7. Tap **OK**.

Using HTC U23 pro as a Wi-Fi hotspot

Share your data connection with other devices by turning HTC U23 pro into a Wi-Fi hotspot.



- Make sure the data connection is turned on before sharing HTC U23 pro as a Wi-Fi hotspot.
- Contact your mobile service provider if a hotspot feature needs to be added to your data plan.

1. On the Home screen, tap **Settings**.
2. Tap **Network & internet > Hotspot & tethering > Wi-Fi hotspot**.
3. Enter a Wi-Fi hotspot name or use the default name.
4. Choose the type of security and set the password for your Wi-Fi hotspot. If you selected **None** in Security, you don't need to enter a password.



The password is the key other people need to enter on their device so they can connect and use HTC U23 pro as a Wi-Fi hotspot.

5. Tap the Use Wi-Fi hotspot **On/Off** switch to turn it on.

HTC U23 pro is ready to be used as a Wi-Fi hotspot when you see  on the status bar.



After turning on Wi-Fi hotspot, tap  on the Wi-Fi Hotspot settings screen to share the password as a QR code. This allows you or people you trust to easily get the password on other devices without having to type it manually.

Sharing your Internet connection over USB

No Internet connection available for your computer? No problem. Use the data connection of HTC U23 pro to connect to the Internet.



- You may need to have USB tethering added to your data plan, and it may incur additional cost. Contact your mobile service provider for details.
- Make sure that mobile data is turned on.

1. Connect HTC U23 pro to your computer using a USB Type-C cable.
2. On the Home screen, tap **Settings**.
3. Tap **Network & internet > Hotspot & tethering**.
4. Tap the USB tethering **On/Off** switch to turn it on.

Apps and notifications

Notifications

Notification icons inform you of new messages, calendar events, alarms, and activities in progress such as files downloading.



When you see notification icons, open the Notifications panel to check out details of the notifications that you've received.

To open the Notifications panel, swipe down from the top of the screen.

You can also swipe down anywhere on the Home screen.

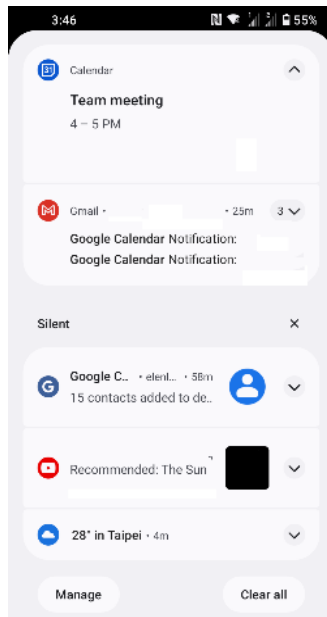

- Tap the notification to open the corresponding app.
- To expand a notification, tap ∨ .
- Some notifications allow you to take immediate action. For example, tap a missed call notification to return the call or reply with a text message.
- To dismiss one notification, drag it left or right.
- To dismiss all notifications, scroll to the bottom of the list, and then tap **Clear all**.
- To clear all silent notifications, tap **X** next to **Silent**.

- To change what app notifications you want to receive, tap **Manage**. For more details, see [Managing app notifications](#) on page 59.

Managing app notifications

You can turn notifications on or off for certain apps. Here's how:

1. From the Home screen, tap **Settings** > **Notifications**.
2. Tap **App settings**.
By default, **Most recent** apps will be listed. These are apps that recently sent you notifications.
3. Tap the dropdown menu to filter the app list. You can choose to display **All apps**.
4. Tap an app and do any of the following:
 - Tap the switch next to **All <app name> notifications** to turn all of the app's notifications on or off.
 - Choose specific types of notifications to turn on or off.

App shortcuts

If an app provides shortcuts to some of its common functions, you'll see them when you press and hold the app icon.



Not all apps support this feature.

1. Press and hold an app icon on the Apps screen or Home screen.
2. From the menu, tap the shortcut you want to use.

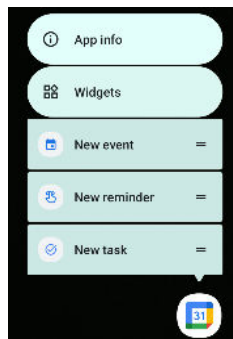

You can drag a shortcut from the menu to add it to the Home screen.

Switching between recently opened apps

It's easy to switch between apps you've opened recently.

Press  to see your recently-opened apps.

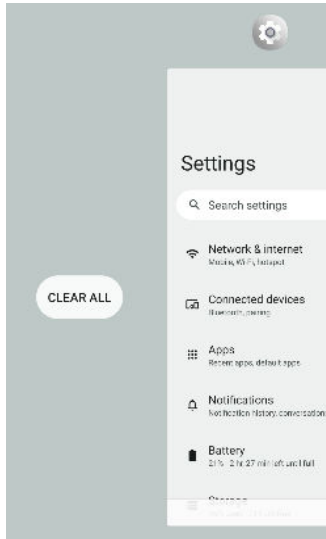

- To go back to an app, scroll through the cards to find the app and tap it.
- To remove an app, drag it up.
- To remove all the apps from this list, swipe right until you see **Clear all** and then tap it.

Working with two apps at the same time

Split-screen view allows you to use two apps at the same time.

1. Open the first app you want to use, and then press .
2. At the top border of the app, press the app icon.
3. Tap **Split top**.
4. Tap an app you want to use on the second screen from the recent apps list.

To turn off split-screen view, drag the handle of the screen divider to the top or bottom edge of the screen.

Using picture-in-picture

Keep a small window of the video you're watching or a supported app onscreen while you do other things on HTC U23 pro.



Not all apps support picture-in-picture.

1. Open a supported app, such as a video player or video call app, and start the video. Display the video in full screen.
2. Press ● .
The video continues to play in a small window at the bottom-right corner of the screen.
3. While viewing the video, you can do other things at the same time, such as use another app.
4. Drag the small window to move it to another position.
Double-tap the window to display the video in full screen again.

How do I check whether an app supports picture-in-picture?

The app info will show the picture-in-picture feature if the app supports it.

1. Press and hold the app icon, and then tap ⓘ .
2. Under **Advanced** on the App info screen, check if **Picture-in-picture** is available. This feature is enabled by default.



- To disable this feature in the app, tap **Picture-in-picture**, and then turn off **Allow picture-in-picture**.
- To check which apps support picture-in-picture, go to **Settings**, and then tap **Apps > Special app access > Picture-in-picture**.

Turning the location setting on or off

When the location setting is enabled, you'll get information such as weather forecasts, nearby restaurants, and driving route suggestions in your apps based on your current location.

1. From the Home screen, tap **Settings > Location**.
2. Turn **Use location** on or off to enable or disable the location setting.



If you disable the location setting, apps and services will not be able to get your device location, but you may still get local results and ads based on your device's IP address.

Choosing which apps have access to your location

Check which apps have access to your location. You can set whether to allow or deny location access for each app.

1. From the Home screen, tap **Settings > Location**.
2. Tap **App location permissions**.
3. Tap the app whose location permission you want to change.
4. Select one of the following options:

Option	Description
Allow all the time	Always give the app location access, even when you're not using the app. This option may not be available in some apps.
Allow only while using the app	Give location access only when you're using the app.
Ask every time	Every time you open the app, it will prompt you to grant location access.
Don't allow	Stop the app from accessing your location.

Changing an app's permissions

When you open apps for the first time, you may be prompted to grant them permission to use various features of your phone, such as device location, camera, or microphone.

- If you suspect a certain app of being malicious or requesting unnecessary permissions, you should select **Don't allow**.
- If you chose not to grant permissions in a trusted app, the app might not work or have limited functionality. If this happens, you can go to Settings and change the app's permissions.

Here's how to change an app's permissions:

1. On the Home screen or Apps screen, press and hold an app, and then select **App info**.
2. Tap **Permissions**.
Permission types that the app is allowed or not allowed to use will be displayed.
3. Tap a permission type. Then choose whether you want the app to use this permission.

Setting default apps

In Settings, you can choose default apps for web browsing, text messaging, and more.

1. On the Home screen, tap **Settings**.
2. Tap **Apps**.

3. Tap **Default apps**.
4. Choose your default launcher, web browser, text messaging apps, and more.

Disabling an app

Apps, even if not used often, may be running in the background and downloading data. If an app cannot be uninstalled, you can disable it.

1. On the Home screen, tap **Settings**.
2. Tap **Apps**.
3. At the bottom of Recently opened apps, choose to see all apps.
4. Tap the app, and then tap **Disable**.



You can also press and hold an app on the Home screen or Apps screen, tap **i**, and then tap **Disable**.

Downloading apps from the web

Download and install apps only from websites that you trust.



Installing apps from unknown sources may put your phone and personal information at risk.

1. In your mobile browser, go to the website that has the APK file of the app and download it.
2. When prompted, tap **Settings**, and then turn on **Allow from this source**.
3. After downloading the APK file, tap the file to install it.

Do not disturb mode

In times when you don't want to be interrupted by your phone, you can turn on Do not disturb mode. This mode can mute sounds, stop vibration, and block visual notifications. You can customize what you want to block and allow.

Here's how to turn Do not disturb mode on or off:

1. With two fingers, swipe down from the top of the screen to open Quick Settings.



2. Tap the **Do Not Disturb**.



If you don't see the **Do Not Disturb** tile, swipe to the next screen in the Quick Settings panel to find it.

Hiding or muting notifications

Choose whether to hide pop-up notifications or mute the notification sound.

1. From the Home screen, tap **Settings > Sound & vibration > Do Not Disturb**.
2. Tap **Display options for hidden notifications**, and then select an option:

Option	Description
No sound from notifications	Mutes the notification sound but still displays visual notifications.
No visuals or sound from notifications	Prevents visual notifications from appearing and mutes their sound.
Custom	Lets you choose what restrictions to apply when the screen is on or off.

Choosing which notifications to block or allow

Choose what types of notifications you want to block or allow in Do not disturb mode.

1. From the Home screen, tap **Settings > Sound & vibration > Do Not Disturb**.
2. Under **What can interrupt Do Not Disturb**, choose any of the following:

Type	Description
People	Block or allow calls, messages, or conversations.
Apps	Choose which apps to allow notifications to show.
Alarms & other interruptions	Block or allow interruptions that make sound such as alarms, touch sounds, or reminders.

Setting exceptions

Set exceptions that can pass through so you can still receive calls or messages from certain contacts.

1. From the Home screen, tap **Settings > Sound & vibration > Do Not Disturb**.
2. Tap **People**.
3. Choose your exceptions:

Type	Options
Messages	<p>Receive messages from Anyone, Contacts, Starred contacts, or Priority conversations.</p> <p>Tip: Tap  next to Priority conversations, select a contact name or number, and then tap Priority. The selected contact will be added under Priority conversations.</p>
Calls	<p>Receive calls from Anyone, Contacts, or Starred contacts.</p> <p>Tip: Turn on Allow repeat callers to allow calls to pass through if the same contact calls twice in 15 minutes.</p>

Setting various schedules

You can set various schedules of when to turn Do Not Disturb mode on and off and customize settings for each schedule.

1. From the Home screen, tap **Settings > Sound & vibration > Do Not Disturb**.
2. Tap **Schedules**.
3. Customize settings for the following default types of schedules:

Schedule type	Steps
Sleeping	<p>Set a Do Not Disturb mode schedule for bedtime.</p> <ol style="list-style-type: none"> 1. Select Sleeping. 2. Set the days, start time, and end time when to enable and disable Do Not Disturb mode.
Event	<p>Set a Do Not Disturb mode schedule for meetings or calendar events.</p> <ol style="list-style-type: none"> 1. Select Event. 2. Tap During events for, and then choose which calendar you want to apply the schedule to. 3. Tap Where reply is. Then choose which calendar events your schedule will apply to: events you've replied to with "Yes", "Yes or Maybe", or all events.

Schedule type	Steps
Driving	Select this option to automatically turn on Do Not Disturb when you're in a moving vehicle.

- To create more schedules, tap **Add more** and choose whether to create an **Event** or **Time** schedule. Then customize the settings for your schedule.



To set exceptions for a schedule, tap **Do Not Disturb behavior**. Select **Create custom settings for this**, and then tap .

Setting a duration for Do Not Disturb mode

If you just need Do Not Disturb mode for one-time use, you can set a duration for it instead of creating a schedule.

- From the Home screen, tap **Settings > Sound & vibration > Do Not Disturb**.
- Tap **Duration for Quick Settings**.
- Choose how long you want Do Not Disturb mode to stay on and tap **OK**.
- Open the Quick Settings panel and tap **Do not disturb** to turn it on.



The duration setting only works when using the **Do not disturb** tile in Quick Settings.

Wireless sharing

Turning Bluetooth on or off

1. From the Home screen, tap **Settings** > **Connected devices**.
2. Tap **Connection preferences** > **Bluetooth**, then tap the **On/Off** switch to turn the Bluetooth connection on and off.
3. Tap **Pair new device** to see a list of available devices.



Turn off Bluetooth when not in use to save battery power, or in places where using a wireless device is prohibited, such as on board an aircraft and in hospitals.

Connecting a Bluetooth headset

You can connect a compatible Bluetooth accessory such as a Bluetooth A2DP stereo headset to HTC U23 pro.



Before you connect your headset, make it discoverable so HTC U23 pro can find it. Refer to your headset manual for details.

1. Turn Bluetooth on and check the list of available devices.
See [Turning Bluetooth on or off](#) on page 67.
2. Tap the name of your headset in the Available devices section. HTC U23 pro pairs with the headset and the headset connection status is displayed in the Media devices section.
3. If prompted to enter a passcode, try 0000 or 1234, or consult the headset documentation to find the passcode.

Reconnecting a Bluetooth headset

Normally, you can easily reconnect your headset by switching on Bluetooth on HTC U23 pro, and then turning on the headset.

However, you might have to connect manually if your headset has been used with another Bluetooth device.

1. Turn Bluetooth on and check the list of paired devices.
See [Turning Bluetooth on or off](#) on page 67.
2. In the Saved devices section, tap **See all**, and then tap the headset's name.
3. If prompted to enter a passcode, try 0000 or 1234, or consult the headset documentation to find the passcode.

If you still cannot reconnect to the headset, follow the instructions in [Unpairing from a Bluetooth device](#) on page 68, and then follow the steps under [Connecting a Bluetooth headset](#) on page 67.

Unpairing from a Bluetooth device

1. Turn Bluetooth on and check the list of paired devices.
See [Turning Bluetooth on or off](#) on page 67.
2. In the Saved devices section, tap **See all**, and then tap  next to the device to unpair.
3. Tap **Forget**.

Receiving files using Bluetooth

HTC U23 pro lets you receive various files with Bluetooth including photos, contact info, and documents such as PDFs.



Refer to the device's documentation for instructions on sending information over Bluetooth.

1. Turn Bluetooth on.
See [Turning Bluetooth on or off](#) on page 67.
2. On the sending device, send one or more files to HTC U23 pro.
3. If asked, accept the pairing request on HTC U23 pro and on the sending device. You may also be prompted to enter the same passcode or confirm the auto-generated passcode on both devices.

You'll then get a Bluetooth authorization request.
4. Tap **Pair**.
5. When HTC U23 pro receives a file transfer request notification, slide the Notifications panel down, tap the incoming file notification, and then tap **Accept**.

6. When a file is transferred, a notification is displayed. Slide the Notifications panel down, and then tap the relevant notification.
7. Tap the received file to view it.

Using NFC

With built-in NFC (near field communication) on HTC U23 pro, you can make contactless payments through certain payment apps such as Google Pay™. You may also be able to read data from NFC cards or other devices through supported apps.



To do contactless payment or read data, you must turn NFC on. Make sure the NFC area (shaded) on the back of HTC U23 pro is close to the terminal, card, or device when you tap your phone.

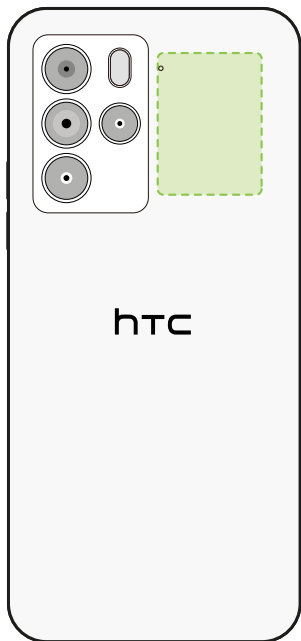

To learn more about Google Pay, visit support.google.com/pay.

Turning NFC on or off

1. On the Home screen, tap **Settings**.
2. Tap **Connected devices** > **Connection preferences** > **NFC**, and then tap the **Use NFC On/Off** switch to turn it on and off.

Battery settings

Using Battery Saver mode

Battery Saver mode helps to increase battery life. Here are some of the things this mode does to save battery:

- Turn off location services when the screen is off.
- Restrict apps from doing things in the background, if they have battery optimization enabled.
- Restrict apps from syncing data in the background.
- Turn off Hey Google voice detection when the screen is off.

You can manually turn on Battery Saver mode or set it to turn on automatically when the battery level reaches a certain percentage.

1. On the Home screen, tap **Settings**.
2. Tap **Battery > Battery Saver**.
3. Toggle **Use Battery Saver** on or off.

To set at what battery level to automatically switch this mode on, tap **Set a schedule > Based on percentage**. Adjust the slider to set the battery level.



You won't be able to turn off Dark theme if Battery Saver mode turned it on automatically. Turn off Battery Saver mode if you want to turn off Dark theme.

Displaying the battery percentage

You can check the percentage of remaining battery power right from the status bar.

1. On the Home screen, tap **Settings**.
2. Tap **Battery**.
3. Tap the Battery percentage **On/Off** switch to show the battery percentage on the status bar.

Checking battery usage

See how the system and apps are using the battery and how much power is being used.

1. On the Home screen, tap **Settings**.

2. Tap **Battery**.

You'll see how much power is left and about how long it will last.

3. Tap **Battery usage**.

Apps and their battery usage time since the last full charge will be displayed.

Another way to check the battery usage per app is to go to **Settings**, and then tap **Apps** > **See all ___ apps**. Tap the app you want to check, and then tap **App battery usage**.

Enabling background restriction in apps

In some apps, you can enable background restriction to prevent them from using the battery while running in the background.



When background restriction is enabled, the restricted apps may not work as usual and notifications may be delayed.

1. From the Home screen, tap **Settings** > **Apps**.

2. Under Recently opened apps, tap an app you want to configure.

If you don't see the desired app, tap **See all ___ apps**, then tap the app that you want.

3. On the App info screen, tap **App battery usage**.

4. Select **Restricted**.

Repeat the above steps to turn on background restriction in other apps.

Checking which apps are battery restricted

1. On the Home screen, tap **Settings**.

2. Tap **Battery** > **Adaptive Battery**.

3. Tap **Restricted apps** to see the list of battery restricted apps.



- You'll see this option only when there are apps running in the background that you've restricted from using the battery.
- On the Restricted apps screen, you can enable or disable restriction for each app.

Security settings

Setting a screen lock

Help protect your personal information and help prevent others from using HTC U23 pro without your permission.

Choose to set a screen lock pattern, numeric PIN, or other means of locking your screen. You'll be asked to unlock the screen every time HTC U23 pro is turned on or when it's idle for a preset period of time.

1. From the Home screen, tap **Settings** > **Security**.
2. Under Device security, tap **Screen lock**.
3. Select a screen lock option and set up the screen lock.
4. Next to **Screen lock**, tap  > **Lock after screen timeout**, then specify the idle time before the screen locks.



If you've set up a screen lock pattern and you don't want the pattern shown as you draw it, tap  and tap the **Make pattern visible On/Off** switch to turn it off.

Setting up Smart Lock

Smart Lock keeps your phone unlocked when it's safe with you, such as when your phone is in your pocket or you're at home. After you set up Smart Lock, you won't need to manually unlock the phone.





Available Smart Lock options vary depending on the phone model.

1. From the Home screen, tap **Settings** > **Security**.
2. Tap **More security settings** > **Smart Lock**.



You need to have a screen lock set up before you can use Smart Lock. If you haven't set up a screen lock, tap **Screen lock**. This will be your alternate screen lock method.

3. Confirm your screen lock.
4. Choose from the available options and set when you want to keep the phone unlocked. For instance, when:
 - You're carrying the phone
 - You're in a trusted location such as your home or office
 - The phone is connected to a trusted device such as your Bluetooth watch or car system

5. Follow the onscreen instructions, and then press  to return to the Security screen.
6. Under Device security, tap  next to **Screen lock**, tap **Lock after screen timeout**, and then specify the idle time before the screen is locked.

Fingerprint sensor

You can quickly wake up and unlock the HTC U23 pro using your fingerprint. You can add up to 5 fingerprints.

When setting up and using the fingerprint sensor, follow these tips:

- Make sure your finger and the fingerprint sensor are dry and clean.
- Use the entire pad of your finger, including the sides and tip.
- When recording your fingerprint, touch the sensor until your phone vibrates.
- The fingerprint sensor has 360° readability—you can touch a recorded finger at any angle to the sensor to turn on the screen or unlock the HTC U23 pro.



You may not be able to set the fingerprint sensor to unlock HTC U23 pro, if you've signed in to an Exchange ActiveSync® account that requires you to set a different screen lock option (such as password). Check with your Exchange Server administrator if your Exchange ActiveSync account supports the fingerprint sensor.

Adding a fingerprint the first time

1. From the Home screen, tap **Settings > Security**.
2. Tap **Fingerprint**.
If you haven't already set up a screen lock, you'll be asked to set one up. See [Setting a screen lock](#) on page 73.
3. If prompted, choose how you want to show notification content when your phone is locked, and then tap **Done**.
4. Tap **Next**.
5. Place your index finger from your left hand or your thumb from your right hand on the fingerprint sensor to start scanning.
6. Repeatedly touch the sensor on the Power button and lift your finger or thumb until the fingerprint has been successfully recorded.
7. After you've successfully recorded your fingerprint, tap **Done**.

You can now use your fingerprint to wake up and unlock HTC U23 pro.



You'll need to input your backup lock screen pattern, PIN, or password if the sensor doesn't identify your fingerprint after five attempts.

Adding, removing, or editing fingerprints

1. From the Home screen, tap **Settings > Security**.
2. Tap **Fingerprint**.
3. Enter your pattern, PIN, or password.
4. Do any of the following:
 - Tap **Add fingerprint** to add another fingerprint.
 - Tap a recorded fingerprint to rename it.
 - Tap  next to a recorded fingerprint to delete it.

About Face Unlock

With Face Unlock, you can set up HTC U23 pro to unlock the screen with your face when the screen is on.

For best face scanning results

Follow these tips when registering your face:

- Do the face scan indoors in a well-lit environment.
- Do not cover your face with an object such as sunglasses, mask, or hat.
- Hold your phone at face level and at a distance of 20 to 50 cm (8 to 20 in) from your face.
- Stay still and do not move your phone while the phone scans your face.



Face Unlock is less secure since your phone could be unlocked by someone or something that contains or looks like your image. If you have concerns, use other more secure authentication methods such as a screen lock pattern, PIN, or password.

Setting up Face Unlock

1. From the Home screen, tap **Settings > Security > Face Unlock**.
2. If you haven't already set up a screen lock, you'll be asked to choose and set up a backup pattern, PIN, or password for unlocking your phone. See [Setting a screen lock](#) on page 73.
3. Read the tips and reminders, then tap **Continue**.
4. Follow the onscreen instructions to scan your face.

Unlocking your phone with Face Unlock

You need to be on the lock screen to use Face Unlock for unlocking your phone.

1. If the screen is off, press the Power button to wake up the screen.
2. Hold your phone in portrait orientation at face level and look at the front camera.

Your phone will bypass the Security screen and unlock.

Display and sound settings

Setting when to turn off the screen

After a period of inactivity, the screen turns off to conserve battery power. You can set the idle time before the screen turns off.

1. From the Home screen, tap **Settings** > **Display**.
2. Tap **Screen timeout**, and then select the time before the screen turns off.



When **Screen attention** is enabled, the screen will not turn off while you're looking at it. This feature uses the front camera to determine whether you're looking at the screen.

Screen brightness

Increase screen brightness to make reading the screen easier, or decrease the brightness level to reduce eye strain.

1. From the Home screen, tap **Settings** > **Display**.
2. Tap **Brightness level**. Drag the slider to set the maximum brightness you want for your screen.



- You can also adjust brightness from the Quick Settings panel. See [Using Quick Settings](#) on page 18.
- When **Adaptive brightness** is enabled, screen brightness will automatically adjust to your lighting condition. This feature uses the ambient light sensor with on-device machine learning to determine the adjustments automatically. You can manually adjust the brightness slider to help your device learn your preferences.

Turn **Adaptive brightness** off if you don't want to use this feature.

Changing the display language

Changing the language adjusts the keyboard layout, date and time formatting, and more.

You can choose several languages and specific dialects so that apps with localized content will display correctly.

1. From the Home screen, tap **Settings** > **System** > **Languages & input**.
2. Tap **Languages**. The first language in the list is the default display language.

3. Tap **Add a language** to add another language to the list, and then select the regional variant of the language.



You can press and hold **=** next to the language you want, and drag it to the beginning of the list to set it as your display language.

4. To remove languages from the list, tap **⋮** > **Remove** and then select the languages you want to remove.

Setting app languages

You can set a different language for each app. Here's how:

1. From the Home screen, tap **Settings** > **System** > **Languages & input**.
2. Tap **App Languages**.
3. Tap an app and then select a language to use for the app.



Changing app languages is available only for apps that have multi-language support.

Changing the default font size

Changing the font size affects the font size used by the system and apps, except for the Google Chrome™ app, which has its own text size settings.

1. From the Home screen, tap **Settings** > **Display**.
2. Tap **Display size and text**.
3. Under Font size, tap **+** or **-**, or drag the slider to increase or decrease the size of fonts.



Swipe left or right under Preview to see the actual look of your selected font size.

Adjusting the display size

Resize items and fonts on the screen to make them easier to see.

1. From the Home screen, tap **Settings** > **Display**.
2. Tap **Display size and text**.
3. Under Display size, tap **+** or **-**, or drag the slider to increase or decrease the size of fonts or items on the screen.



Swipe left or right under Preview to see the actual look of your selected display size.

Dark theme

Dark theme can help reduce eye strain. It displays the system background and supported apps in black.

1. From the Home screen, tap **Settings > Display**.
2. Do one of the following:
 - Tap the Dark theme **On/Off** switch to turn it on.
 - Tap **Dark theme**, and then tap **Schedule** to set the time when to turn on the feature.



When Battery Saver mode is on, your phone also turns on Dark theme automatically. See [Using Battery Saver mode](#) on page 71 for details.

Night Light

Adjust the screen from blue to a warmer color to help reduce eye strain when viewing it at night.

1. From the Home screen, tap **Settings > Display**.
2. Tap **Night Light**, and then tap **Schedule** to set the time when to turn on the feature.
3. With Night Light turned on, drag the **Intensity** slider to adjust the color temperature. Dragging the slider to the right filters out more blue light.



You can also turn **Night Light** on and off from the Quick Settings panel. See [Using Quick Settings](#) on page 18.

Changing your ringtone

You can select a preset ringtone, use a music file, or record and use your voice as the ringtone.



Make sure the volume is on.

1. From the Home screen, tap **Settings > Sound & vibration**.
2. Tap **Phone ringtone**.
3. Do one of the following:
 - Select a preset ringtone.
 - Tap **Add ringtone**. Then find and select the music file you want to use.
You can also tap **Sound Recorder** to record your voice. After saving the file, select the voice recording.
4. When you're done selecting your ringtone, tap **OK**.

Changing your notification sound

You can select a preset sound, use a sound file, or record and use your voice as the notification sound.



Make sure the volume is on.

1. From the Home screen, tap **Settings > Sound & vibration**.
2. Tap **Default notification sound**.
3. Do one of the following:
 - Select a preset sound.
 - Tap **Add notification**. Then find and select the sound file you want to use.
You can also tap **Sound Recorder** to record your voice. After saving the file, select the voice recording.
4. When you're done selecting your notification sound, tap **OK**.

Turning touch sounds and vibration on and off

Some people like the sound or vibration feedback they get when touching the screen, and some don't. You can turn on or off various types of touch sounds and vibration on HTC U23 pro.

1. From the Home screen, tap **Settings > Sound & vibration**.
2. You can turn on or off any of the following:
 - **Dial pad tones**
 - **Screen locking sound**
 - **Charging sounds and vibration**
 - **Touch sounds**

Turning keyboard sound and vibration on or off

Here's how to turn on or off the sound and vibration feedback in Gboard:

1. From the Home screen, tap **Settings > System > Languages & input**.
2. Tap **On-screen keyboard > Gboard > Preferences**.
3. Under **Key press**, you can do any of the following:
 - Turn **Sound on keypress** on or off. If it's turned on, you can set the sound volume.
 - Turn **Haptic feedback on keypress** on or off. If it's turned on, you can set the vibration strength.

Trademarks and copyrights

©2023 HTC Corporation. All Rights Reserved.

HTC, the HTC logo, and all other HTC product and feature names are trademarks or registered trademarks in the U.S. and/or other countries of HTC Corporation and its affiliates.

Google, Android, Google Assistant, Google Drive, Google Duo, Google Pay, and Google Play are trademarks of Google Inc.

licensed by
Qualcomm

Qualcomm is a trademark of Qualcomm Incorporated, registered in the United States and other countries. The Licensed by Qualcomm logo is a trademark of Qualcomm Incorporated.

Exchange ActiveSync is a trademark or registered trademark of Microsoft Corporation in the United States and/or other countries.

The *Bluetooth*[®] word mark and logos are registered trademarks owned by Bluetooth SIG, Inc.

Wi-Fi[®] is a registered trademark of the Wireless Fidelity Alliance, Inc.

LTE is a trademark of European Telecommunications Standards Institute (ETSI).

iPhone is a trademark of Apple Inc. registered in the U.S. and other countries.

microSD is a trademark of SD-3C LLC.

All other trademarks and service marks mentioned herein, including company names, product names, service names and logos, are the property of their respective owners and their use herein does not indicate an affiliation with, association with, or endorsement of or by HTC Corporation. Not all marks listed necessarily appear in this User Guide.

Screen images contained herein are simulated. HTC shall not be liable for technical or editorial errors or omissions contained herein, nor for incidental or consequential damages resulting from furnishing this material. The information is provided “as is” without warranty of any kind and is subject to change without notice. HTC also reserves the right to revise the content of this document at any time without prior notice.

No part of this document may be reproduced or transmitted in any form or by any means, electronic or mechanical, including photocopying, recording or storing in a retrieval system, or translated into any language in any form without prior written permission from HTC.