



EN ■ Hand mixer with a rotating bowl

Translation of the original manual

READ CAREFULLY AND STORE FOR FUTURE USE.

General warnings

- This appliance may not be used by children. Keep the appliance and its power cord away from children.
- The appliance may be used by persons with reduced physical, sensory or mental capabilities or with a lack of experience and knowledge, if they are supervised or have been instructed to use the appliance in a safe manner and understand the potential dangers.
- Children must not play with the appliance.
- Cleaning and maintenance performed by the user must not be performed by unsupervised children.
- In the event that the power cord is damaged, have it repaired at a professional service centre to prevent causing a dangerous situation. It is forbidden to use the appliance if it has a damaged power cord.



Warning:

Incorrect use may lead to injuries.

- Be careful when handling and cleaning the attachments.
- The surfaces of the appliance that come into contact with food must always be cleaned according to the instructions in this user's manual.
- Always turn off the appliance and disconnect it from the power socket if you will not be using it and if you will be leaving it without supervision, before assembly, disassembly, cleaning or moving it.
- Before replacing the accessories or accessible parts that move during use, turn the appliance off and disconnect it from the power supply.

Electrical safety

- Before connecting this appliance to a power socket, make sure that the voltage stated on its rating label corresponds to the voltage in your power socket.
- Connect the appliance only to a properly grounded socket. Do not use an extension cord.
- Do not connect and disconnect the power cord to and from the power socket with wet hands.
- Ensure that the power plug contacts do not come into contact with water or moisture.
- Do not disconnect the appliance from the power socket by pulling on the power cord. This could damage the power cord or the power socket. Disconnect the cord from the power socket by gently pulling the plug of the power cord.
- Do not place heavy items on the power cord. Make sure the power cord does not hang over the edge of a table and that it is not touching a hot surface or sharp objects.
- To avoid the danger of injury by electrical shock, do not repair the appliance yourself or make any adjustments to it. Have all repairs or adjustments of the appliance performed at an authorised service centre. Tampering with the appliance during the warranty period may void the warranty.
- Do not spray the motor unit with water or any other liquid. Never wash it under running water or submerge it in water or another liquid.
- Always turn off the appliance and disconnect it from the power socket when you have finished using it.
- This appliance is not designed to be controlled using a programmed device, external timer switch or remote control.

Correct use of the appliance

- The appliance is intended and designed for processing a standard amount of food in the household.
- Do not use the appliance for a purpose other than that for which it is designed.
- This appliance is designed for use in indoor areas only. Never use it in an outdoor or industrial environment.
- This appliance must be used only in accordance with the instructions contained in this user's manual.
- Only use the appliance with the original accessories that came with it.



Attention:

Using non-original accessories may result in a dangerous situation arising.

- Do not use sprays in the vicinity of the appliance.
- Only place the appliance on an even, dry surface. Do not place the appliance on window sills or on unstable surfaces. Likewise, do not place the appliance on an electric or gas stove or in its vicinity, do not place it in the vicinity of an open fire or an appliance that is a source of heat.
- Do not use the appliance when it is not functioning correctly or after it has fallen on the floor, been submerged in water or is damaged in any other way. Hand it over to an authorised service centre for inspection or repair.
- It is forbidden to modify the surface of the appliance in any way, e.g. using self-adhesive wallpaper, foil, etc.
- Before first use, it is necessary to thoroughly wash the accessories (beater/kneading attachments and rotating bowl) using warm water and kitchen detergent, then rinse them with drinking water and wipe thoroughly until dry using a fine wiping cloth.
- Before putting the appliance into operation, check that it is correctly assembled and that the stand arm is in the horizontal position. Never combine various types of attachments.
- Do not use the appliance if you have wet hands.
- Do not cover the appliance's vents.
- Do not turn on the appliance when it is empty. Incorrect use of the appliance may negatively affect its lifetime.
- Only run the appliance after submerging the attachments in the bowl with the ingredients. To prevent food from splashing out, keep the attachments submerged in the container while the appliance is running.
- If food sticks to the attachments or the inside of the bowl, turn off the appliance and disconnect it from the power socket. Use a spatula to clean the attachments and the sides of the bowl.
- Avoid coming into contact with the rotating parts of the appliance. While using it, do not place hands, forks or any other utensils into the bowl with the ingredients, and keep hair, clothing, etc. at a sufficient distance from the rotating parts of the appliance. If a fork or another utensil falls into the container while the appliance is running, immediately it off.
- Do not tilt out the stand arm while mixing.
- Be especially careful when handling hot liquids and foodstuffs. Hot steam or splashing hot foods and liquids may cause scalding. For reasons of increased safety, it is recommended to allow hot liquids and foods to cool down before blending them. Never blend hot foods and liquids directly in a pot located on a turned on hotplate.
- If you have just processed hot foods, the removable attachments may be hot after they are used.
- Before attaching attachments to the appliance, removing or replacing them, ensure that the appliance is turned off and disconnected from the power socket.

Safety during maintenance

- Allow the appliance to always fully cool down before cleaning it.
- Regularly clean the appliance after each use according to the instructions in chapter Maintenance and cleaning. Do not perform any maintenance on the appliance apart from the maintenance procedure described in chapter Maintenance and cleaning.
- Do not wash the motor unit or stand under running water or submerge it in water or another liquid. The motor unit is not designed to be washed in a dishwasher.
- The removable attachments are intended for short term contact with food (including beverages), i.e. max. 4 hours. To prevent damaging their surface, do not leave them submerged, for example in water for extended periods of time.

A

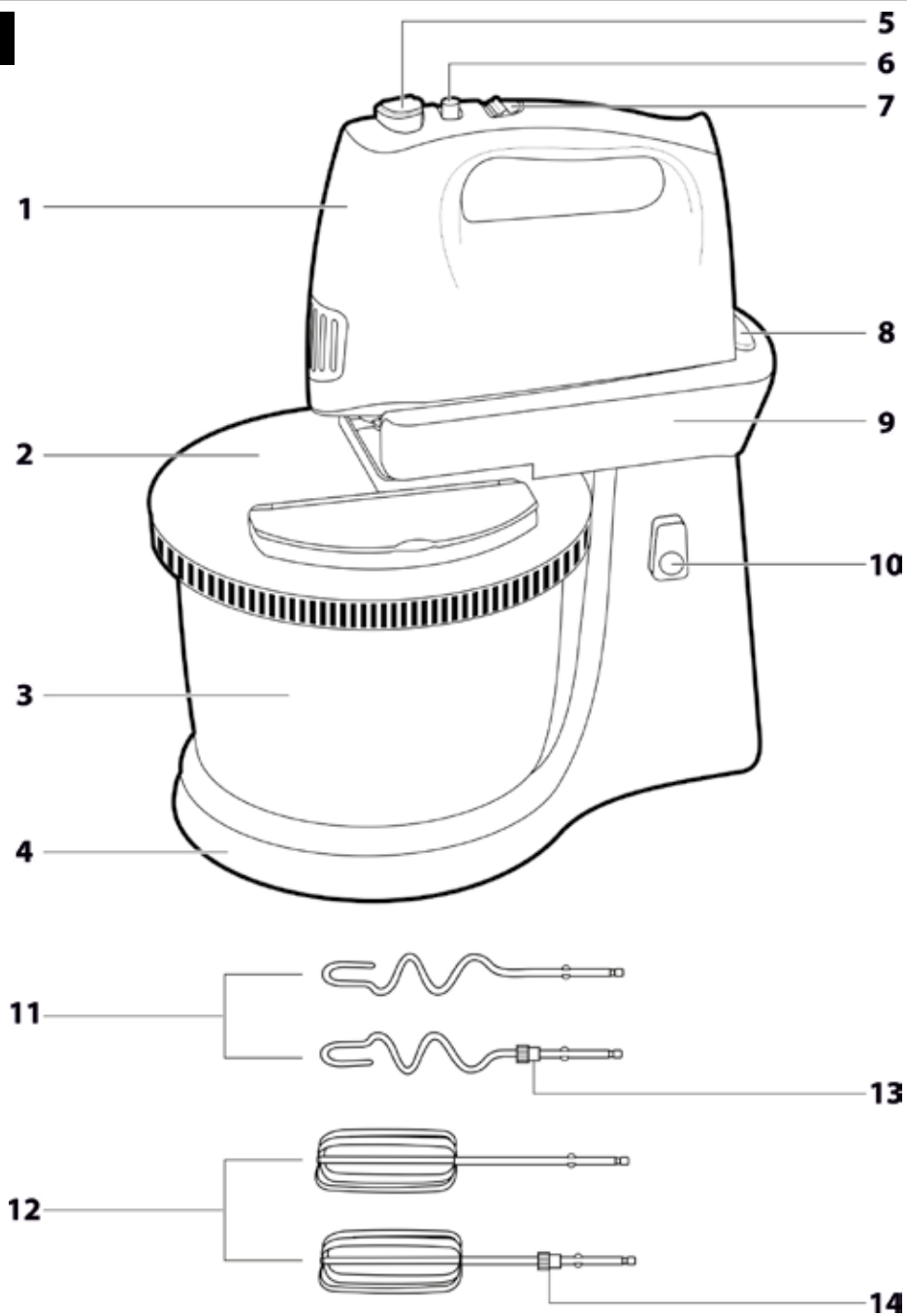

EN Hand mixer with a rotating bowl

User's manual

BEFORE FIRST USE

- Prior to using this appliance, please read the user's manual thoroughly, even in cases, when one has already familiarised themselves with previous use of similar types of appliances. Only use the appliance in the manner described in this user's manual. Keep this user's manual in a safe place where it can be easily retrieved for future use. In the event that you hand this appliance over to somebody else, make sure to also include this user's manual.
- We recommend saving the original cardboard box, packaging material, purchase receipt and responsibility statement of the vendor or warranty card for at least the duration of the legal liability for unsatisfactory performance or quality. In the event of transportation, we recommend that you pack the appliance in the original box from the manufacturer.
- Carefully unpack the appliance and take care not to throw away any part of the packaging before you find all the parts of the appliance.

DESCRIPTION OF THE APPLIANCE AND ACCESSORIES

A1 Motor unit	A10 Button for tilting the stand arm
A2 Bowl lid with filling opening	A11 Set of kneading attachments Suitable for kneading dough
A3 Stainless steel bowl	A12 Set of beater attachments Suitable for whipping whipped cream, creams, mashed potatoes, spreads, egg whites and yolks
A4 Stand with bowl base	A13 Differentiation ring of kneading attachments
A5 Attachment release button	A14 Differentiation ring of beater attachments
A6 Switch for setting speeds and turning off	
A7 TURBO pulse button for maximum speed	
A8 Motor unit release button	
A9 Tilting stand arm	

APPLICATION OF THE HAND MIXER

- The hand mixer is intended for beating and kneading a standard amount of ingredients in the household.
- Food is processed using two types of chrome-plated steel attachments that are easy to wash and exchange.

BEFORE FIRST USE

- Before first use, thoroughly wash all parts that come into contact with food (beater and kneading attachments, bowl and lid) in hot water using neutral dishwashing detergent. Then rinse everything with clean water and allow to dry naturally or dry out thoroughly using a wiping cloth. The attachments are also suitable for washing in a dishwasher.
- Wipe the outer parts of the stand **A4** and tilting arm **A9** using a lightly dampened wiping cloth.



Attention:

Do not rinse or submerge the stand **A4** or motor unit **A1** and its power cord in water. Neither the stand nor the motor unit are intended for washing in a dishwasher.

OPERATION

SELECTING ATTACHMENTS

Beater attachments

- These are used to prepare batter dough, mashed potatoes, whipped cream, whipped egg whites and creams. Do not use the beater attachments to mix yeast dough.

Kneading attachments

- These are used for kneading yeast dough and dough for noodles, for mixing minced meat, spreads and puff dough.

SELECTING A SPEED

Level 1: Suitable as the starting speed for mixing a larger amount of ingredients or dry ingredients.

Level 2: Suitable for processing liquid ingredients and for mixing salad dressings.

Level 3: Suitable for mixing ingredients when preparing cakes, biscuits and bread.

Level 4: Suitable for whipping up butter or sugar when preparing sweets, desserts, etc.

Level 5: Suitable for whipping eggs, sauces, creams, etc.

TURBO button: The TURBO pulse button is equivalent to speed level 5 and is used for a short increase to maximum speed.

ASSEMBLY



Warning:

Prior to assembling the hand mixer, the motor unit **A1** must be disconnected from the mains power socket and the switch **A6** must be set to position 0 (off). Attaching the attachments while the motor unit is connecting to mains power, may result in accidentally turning on the unit and serious subsequent injuries.

- Select the attachment types suitable for the intended task and insert them into the holes on the underside of the motor unit. **ATTENTION** – the connection parts of the attachments are not identical and can only be attached into the intended holes on the underside of the motor unit. The attachment with the differentiation ring (**A13** on the kneading attachment, **A14** on the beater attachment) can only be attached into the right hole on the underside of the motor unit (when viewed from the front), the attachment without the ring can only be inserted into the left hole.
- Push the selected attachments in until they safely click into position. Gently pull on both the attachments to check that they are correctly attached.



Attention:

Do not combine the beaters and the kneading attachments. Only use the same type of attachments at the same time.

- Press button **A10** to release the lock on arm **A9** and tilt open the arm.
- Put the bowl into the stand, filled with the ingredients that you wish to process.
- Press button **A10** and tilt down the arm into the horizontal position.
- Insert the motor unit **A1** with the attached attachments on to the tilting arm and lightly push towards the arm towards it until you hear an audible click. The motor unit is securely attached to the arm when it is not possible to lift it independently.



Note:

The Motor unit can be used independently without the stand. In such a case setup the appliance according to the instructions provided above, continue with chapter TURNING ON AND OFF. It will be necessary to hold the motor unit in your hand during operation.

TURNING ON AND USE

- Plug the power cord of the hand mixer into a power socket.
- Using switch **A6**, set the desired speed in the range of 1–5.
- We recommend to start at a lower speed and to increase it gradually. You can change the speed setting even while the hand mixer is running. We recommend that runny doughs and sauces are processed at lower speed levels; this will prevent ingredients from splashing out of the bowl.



Attention:

Items such as spoons, kitchen knives, forks, etc. must not be placed into the bowl while mixing as this could result in injury or damage to the hand mixer.

- While the appliance is running, the bowl located on the stand will turn automatically. This ensures that ingredients are evenly mixed.
- If you wish to increase the speed to maximum for a short moment, press the TURBO **A7** button. Nevertheless, do not hold down the TURBO button for longer than 30 seconds, otherwise there is a risk of the hand mixer overheating.

Releasing stuck-on ingredients

- If despite the even mixing action achieved by the rotating bowl, some ingredients (e.g. dough) stick to the edge of the bowl, then turn the hand mixer off by sliding switch **A6** to position 0 (off).
- Tilt open the arm by pressing button **A10**.
- Using an ordinary scraper, remove the stuck-on ingredient on the edge of the bowl and put it into the middle of the bowl.
- Press button **A10** and tilt the arm back down into the operating position. Continue processing.

Operating time of the hand mixer

- Use level 1 and 2 only for the initial incorporation of ingredients when making dough. Leave the mixer running no longer than 3 minutes and then switch to a higher level based on the type of filling that is being made.
- When beating, use the mixer continuously for no longer than 10 minutes.
- When kneading thick, heavy dough, do not allow the mixer to run for longer than 5 minutes.
- In the event of overloading (long running time, excessively thick dough, excessive amount of ingredients) the built-in thermal protection will shut off the mixer. If this happens, set the speed switch to zero, pull the power cord out of the power socket and allow the mixer to cool down for approximately 15 minutes.

QUICK GUIDE TO MIXING

Beater attachments

Ingredients	Amount	Processing time	Speed selection
Egg whites	max. 5 egg whites	4 minutes	level 5
Mashed potatoes	max. 750 g	4 minutes	level 4
Creams	approx. 750 ml	4 minutes	level 5
Mayonnaise	max. 3 egg yolks	3 minutes	level 5
Whipped cream	max. 500 g	5 minutes	level 5
Cake dough	approx. 750 g	4 minutes	level 3

Kneading attachments

Ingredients	Amount	Processing time	Speed selection
Yeast dough	max. 500 g of flour	5 minutes	level 3



Note:

The above processing times are only a reference. To prevent ingredients from splattering out of the bowl, select an initial speed level of 1 or 2. Then set a higher speed as required. For easier mixing of dough we recommended soft margarine or butter.

TURNING OFF AND REMOVING THE ATTACHMENTS

- After you have finished using the appliance, set switch **A6** to position 0 (off) and disconnect the power cord from the power socket.
- Press button **A10** and tilt open the arm **A9**.
- Press button **A8** to release the lock of the motor unit and take the unit off.
- To release the lid, press button **A5**. The attachments can only be released when the switch is in position 0.
- When the switch is in positions 1–5, the attachments are locked in position against removal.
- Then clean the hand mixer and all its parts according to the instructions in chapter **CLEANING AND MAINTENANCE**.

OVERHEATING PROTECTION

The hand mixer is equipped with an overheating protection fuse. When it is used for longer than 10 minutes for beating or 5 minutes for kneading or for processing very tough ingredients, and the motor unit heats up to a high temperature, the hand mixer will turn off automatically. In such a case, pull out the power plug and allow the hand mixer to cool down sufficiently. Then you can put it into operation again.

CLEANING AND MAINTENANCE



Attention:

Prior to cleaning or maintenance, always disconnect the hand mixer from the power supply and allow it to cool down completely. The motor unit and its power cord, stand, beater and kneading attachments, and the lid of the bowl are not intended for washing in a dishwasher. Only the stainless steel bowl is suitable for washing in a dishwasher.

Do not spray the stand, the motor unit or its power cord with water or any other liquid, or submerge it in water or any other liquid.

- Thoroughly wash the removed used attachments using warm water and neutral kitchen detergent. Then rinse all these parts with clean water and dry them thoroughly with a fine wiping cloth. The attachments can also be washed in a dishwasher.



Attention:

The attachments are intended for short term contact with food (including beverages), i.e. max. 4 hours. To prevent damaging their surface, do not leave them submerged, for example in water for extended periods of time.

- To clean the outer surface of the motor unit and the stand, use a cloth lightly dipped in a weak detergent solution. After applying the detergent solution, wipe the surface with a cloth lightly dampened in clean water and then wipe dry.



Attention:

Never use chemicals, dishwashing wool, steel wool or cleaning agents with an abrasive component since these may seriously damage the surface of the motor unit or the stand.

STORAGE

- Before storing it, the hand mixer must be completely cool, turned off and disconnected from the power supply, clean and dry.
- Attach the motor unit on to the stand arm and tilt it down into the horizontal position. Store the hand mixer and the attachments in a clean, dry place out of reach of children.



Attention:

Keep the stored hand mixer away from extreme temperatures, direct sunlight and excessive humidity and do not store it in an overly dusty environment. Do not place anything on to the hand mixer.

TECHNICAL SPECIFICATIONS

Rated voltage range	220–240 V AC
Rated frequency.....	50 / 60 Hz
Rated power input	500 W
Length of the power cord.....	1.2 m
Blending bowl capacity	2.5 l
Electrical shock protection class.....	II
Noise level	85 dB(A)

The declared noise emission level of the appliance is 85 dB(A), which represents a level A of acoustic power with respect to a reference acoustic power of 1 pW.

Explanation of technical terminology

Safety class for electrical shock protection:

Class II – Electrical shock protection is provided by double or heavy-duty insulation.

Changes to text and technical parameters are reserved.

INSTRUCTIONS AND INFORMATION REGARDING THE DISPOSAL OF USED PACKAGING MATERIALS

Dispose of used packaging material at a site designated for waste in your municipality.

DISPOSAL OF USED ELECTRICAL AND ELECTRONIC EQUIPMENT



This symbol on products or original documents means that used electric or electronic products must not be added to ordinary municipal waste. For proper disposal, renewal and recycling, hand these products over to determined collection points. Alternatively, in some European Union states or other European countries you may return your appliances to the local retailer when buying an equivalent new appliance.

Correct disposal of this product helps save valuable natural resources and prevents potential negative effects on the environment and human health, which could result from improper waste disposal. Ask your local authorities or collection facility for more details.

In accordance with national regulations penalties may be imposed for the incorrect disposal of this type of waste.

For business entities in European Union states

If you want to dispose of electric or electronic devices, ask your retailer or supplier for the necessary information.

Disposal in other countries outside the European Union.

This symbol is valid in the European Union. If you wish to dispose of this product, request the necessary information about the correct disposal method from the local council or from your retailer.



This product meets all the basic requirements of EU directives related to it.