



Safety Instructions

Read this manual carefully before use, and retain it for future reference.

Usage Restrictions

- This product is for floor cleaning in a home environment only. Do not use it outdoors, on non-floor surfaces, or in a commercial or industrial setting.
- This appliance can be used by children aged from 8 years and above and persons with reduced physical, sensory or mental capabilities or lack of experience and knowledge if they have been given supervision or instruction concerning use of the appliance in a safe way and understand the hazards involved. Children shall not play with the appliance. Cleaning and user maintenance shall not be made by children without supervision.
- This appliance is not intended for use by persons (including children) with reduced physical, sensory or mental capabilities, or lack of experience and knowledge, unless they have been given supervision or instruction concerning use of the appliance by a person responsible for their safety.
- Children should be supervised to ensure that they do not play with the appliance.
- Do not place children, pets, or any item on top of the robot vacuum while it is stationary or moving.
- To avoid potential danger, keep yourself, your pets, and people away from the robot vacuum when it is running.
- This appliance contains batteries that are only replaceable by skilled persons.
- The appliance is only to be used with the power supply unit provided with the appliance.
- If the charger or battery becomes damaged, it must be replaced with a genuine component purchased from the manufacturer or after-sales service department.
- If the pins of the plug parts are damaged, the plug-in power supply shall be scrapped.
- Do not use the robot vacuum in an area suspended above ground level, such as a loft, open balcony, or on top of furniture, unless a protective barrier is present.
- Do not install, charge, or use the robot vacuum outdoors, in a bathroom, or around a pool.
- Do not use the robot vacuum at an ambient temperature above 40°C or below 0°C.
- Do not place the robot vacuum upside down for a long period of time.
- Do not use the protective cover of the laser sensor or the top cover or bumper of the robot vacuum as a handle to move the robot vacuum.
- Pick up any cables from the floor before using the robot vacuum to prevent it from dragging them while cleaning.
- Pick up any fragile or loose items from the floor, such as vases or plastic bags, to prevent the robot vacuum from being obstructed or bumping into them and causing damage.
- Do not use the robot vacuum to clean any burning substances.
- Do not allow the robot vacuum to pick up hard or sharp objects.
- Make sure the robot vacuum is turned off and the power supply is unplugged before cleaning or performing maintenance.
- Do not wipe the robot vacuum or the charging dock with a wet cloth or rinse them with any liquid. After cleaning washable parts, dry them thoroughly before installing them for use.
- The vacuum cleaner should be powered off and kept in its original packaging during transport.
- Only use this product as directed in the user manual. Users are responsible for any loss or damage arising from improper use of this product.

Batteries and Charging

- **WARNING:** Do not use any third-party battery, charging dock.
- Use only with BLJ24WJ200100P-V supply unit.
- Do not attempt to disassemble, repair, or modify the battery or charging dock on your own.
- Do not place the charging dock near a heat source.
- Do not use a wet cloth or wet hands to wipe or clean the dock's charging contacts.
- Take the removed batteries to the professional recycling facility to properly dispose of them.
- If the robot vacuum will not be used for an extended period, fully charge it, then turn it off and store in a cool, dry place. Recharge the robot vacuum at least once every 3 months to avoid over-discharging the battery.
- No action needed from users to shift the charging dock between 50 Hz and 60 Hz, and the product can adapt itself for both 50 Hz and 60 Hz.
- Do not charge non-rechargeable batteries.

Laser Safety Information

- The laser sensor in this product meets the IEC 60825-1:2014 and EN 60825-1:2014/A11:2021 Standard for Class 1 laser products. Please avoid direct eye contact with it during use.
- CLASS 1 LASER PRODUCT
- CONSUMER LASER PRODUCT
- EN 50689:2021



For indoor use only



Before use, read the instructions

Environmental Notice

The lithium-ion battery pack contains substances that are hazardous to the environment. Before disposing of the vacuum, please first remove the battery pack, then discard, or recycle it in accordance with local laws and regulations of the country or region it is used in.

- The battery must be removed from the appliance before it is scrapped.
- The appliance must be disconnected from the supply mains when removing the battery.
- The battery is to be disposed of safely.

Cautions:

- When removing the batteries from the product, it is better to use up the batteries and make sure your product is disconnected from power.
- Remove the entire battery pack at a time.
- Do not damage the battery case to prevent short circuits or leakages of hazardous substances.
- Take the removed batteries to the professional recycling facility to properly dispose of them.
- Do not leave the batteries in a high-temperature environment; otherwise, they may explode.
- In the event of a battery leak, avoid contact with the liquid. If the liquid enters the eyes, rinse with plenty of water and seek medical attention immediately.

Steps to Remove the Battery:

The following instructions are for robot vacuum disposal only and not for regular operation.

1. Keep the robot vacuum away from the charging dock and run it until its battery is depleted.
2. Turn off the robot vacuum, use a tool to remove the screws on the battery pack's cover at the bottom, and then take off the cover.
3. Press down on the clips and pull out the battery pack's connector to take out the battery pack.

Regulatory Compliance Information



EU Declaration of Conformity

Hereby, Xiaomi Communications Co., Ltd. declares that the radio equipment type OV81 is in compliance with Directive 2014/53/EU. The full text of the EU declaration of conformity is available at the following internet address: <https://www.mi.com/global/service/support/declaration.html>
For detailed e-manual, please go to www.mi.com/global/support/user-guide

The product does not have a standby mode or other equivalent state in terms of energy efficiency requirements or power management function, the power consumption of the product is likely to be higher than other products meeting these functional requirements.



WEEE Disposal and Recycling Information

All products bearing this symbol are waste electrical and electronic equipment (WEEE as in directive 2012/19/EU) which should not be mixed with unsorted household waste. Instead, you should protect human health and the environment by handing over your waste equipment to a designated collection point for the recycling of waste electrical and electronic equipment, appointed by the government or local authorities. Correct disposal and recycling will help prevent potential negative consequences to the environment and human health. Please contact the installer or local authorities for more information about the location as well as terms and conditions of such collection points.

Product Overview

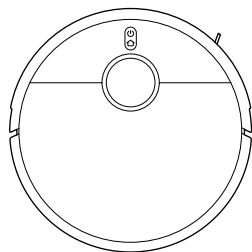

Robot Vacuum

Robot Vacuum

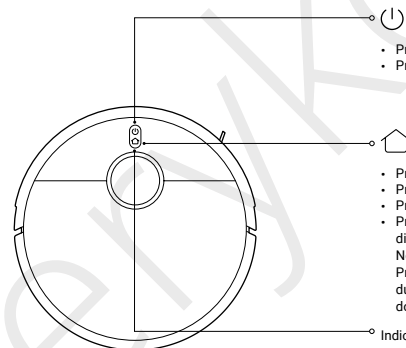

- Press and hold for 3 seconds to turn on or off
- Press to clean/pause while turned on

- Press to pause while running
- Press to start docking when it is paused
- Press to stop docking when it returns to dock
- Press and hold for 3 seconds to enable or disable the child lock

Note:

Press any button on the robot vacuum to pause during operation or returning to the charging dock.

Indicator

- White: Working normally
- Breathing white: In charging (medium/high battery level)
- Blinking white: Positioning/Returning to the charging dock
- Yellow: Wi-Fi disconnected
- Blinking yellow: Running (low battery)/Awaiting connection/Robot vacuum error
- Breathing yellow: In charging (low battery level)
- Blinking blue: Connecting to Wi-Fi/Updating
- Blue: Wi-Fi connected
- Off: Shutdown/In sleep

Pre-installed Accessories



Brush

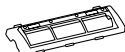

Brush Cover



Dust Compartment

Other Accessories

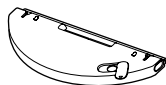

Mop Pad and Water Tank Assembly (with mounted mop pad)



Side Brush



Power Supply



Charging Dock

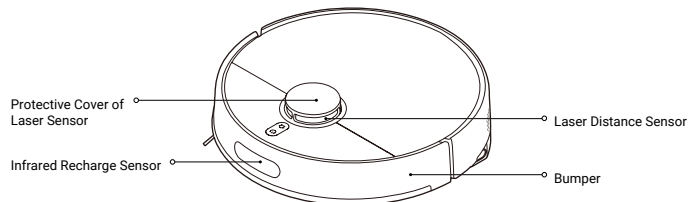

Protective Cover of Laser Sensor

Laser Distance Sensor

Infrared Recharge Sensor

Bumper

Note: Illustrations of product, accessories, and user interface in the user manual are for reference purposes only. Actual product and functions may vary due to product enhancements.

Product Overview

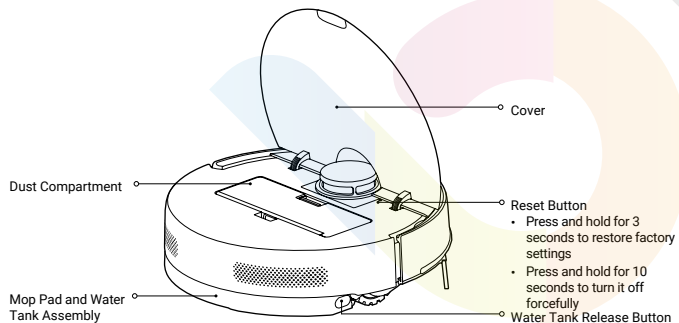
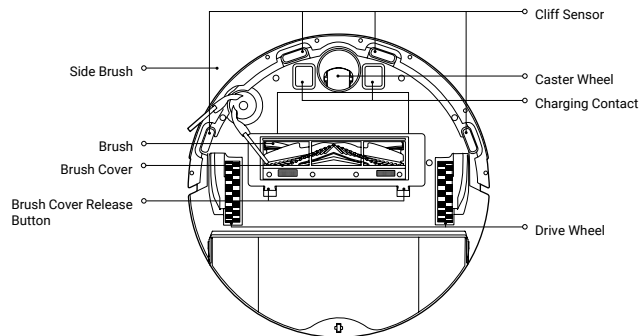

Charging Dock

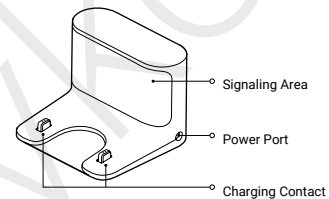

Dust Compartment

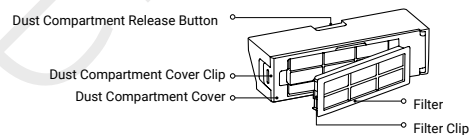

Mop Pad and Water Tank Assembly

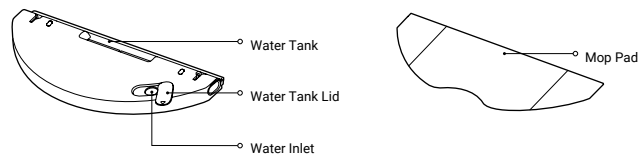

Before Use

Removing Protective Coverings

Remove the protective strips 1 and 2 and protective films 3 and 4 before use.

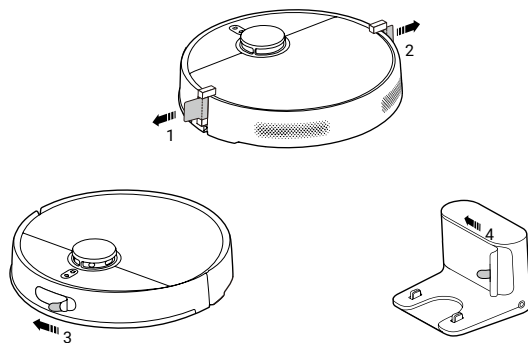

Installing the Side Brush

Install the side brush onto the clip on the bottom of the robot vacuum.

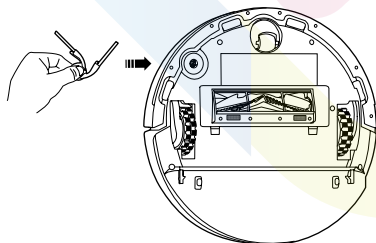

Charging the Robot Vacuum

- Place the charging dock near an electrical outlet in an area with good signal coverage. Then connect the charging dock to power.
- Place the robot vacuum on the charging dock and make sure their charging contacts are aligned. The robot vacuum will automatically turn on and charge. It cannot be turned off while charging.

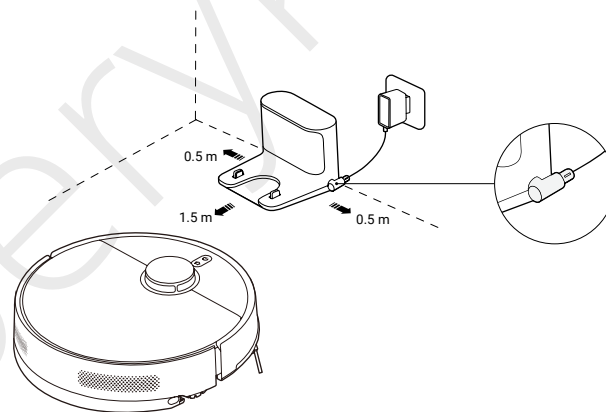

Cautions:

- Do not expose the charging dock to direct sunlight.
- Do not place any objects within 0.5 meters on either side of the charging dock and 1.5 meters in front of it.
- To ensure the battery's optimal performance, fully charge the battery for the first time before use.

How to Use

Connecting with the Xiaomi Home App

This product works with the Xiaomi Home app. Control your device with Xiaomi Home app.

Scan the QR code to download and install the app. You will be directed to the connection setup page if the app is installed already. Or search for "Xiaomi Home" in the app store to download and install it.

Open the Xiaomi Home app, tap "+" on the upper right, and then follow the instructions to add your device.



Notes:

- Only 2.4 GHz Wi-Fi networks are supported.
- The version of the app might have been updated, please follow the instructions based on the current app version.
- When the robot vacuum connects with the Xiaomi Home app successfully, it connects with the network successfully. You can have a reset of Wi-Fi to disconnect it from the network.



1CB9CF8B

Resetting the Wi-Fi

Make sure the robot vacuum is turned on, and simultaneously press and hold the buttons  and  for 7 seconds. When you hear a voice message, the robot vacuum is waiting for the network connection and the Wi-Fi is reset successfully.

Restoring Factory Settings

Press and hold the reset button for 3 seconds. Then, the robot vacuum restarts, and the factory settings are restored successfully.

Quick Mapping

- After the robot vacuum connects to the network for the first time, follow the instructions in the app to quickly create a map. The robot vacuum will start mapping without cleaning.
- Once it has returned to the charging dock, the mapping process is completed and the map is saved automatically.



Preparation before mapping

- Ensure the robot vacuum has been fully charged and starts from the charging dock.
- Open the doors to your rooms, organize the scattered items on the floor, and clear any objects that may affect the operation of the robot vacuum to ensure accurate mapping.
- It is recommended to block areas unsuitable for the robot vacuum, such as places where it may get stuck or be scraped.

Settings after mapping

- It is recommended to set up virtual walls or restricted areas in places with long-hair or fringe carpets, or other places where the robot vacuum may get stuck or be scraped.
- Set up virtual walls or restricted areas to exclude carpeted areas before mopping to prevent the carpet from getting wet.

Starting Vacuuming

Press the button  on the robot vacuum or tap  in the app to start cleaning. The robot vacuum will automatically return to the charging dock to charge once the cleaning is completed.

Method 1: Press the button  on the robot vacuum.

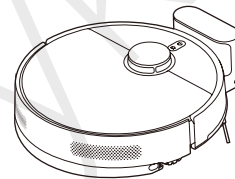

Method 2: Tap  in the app.

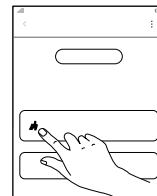

Notes:

- Make sure the robot vacuum starts cleaning from the charging dock. Do not move the charging dock or the robot vacuum during cleaning.
- When using the robot vacuum for the first time, it is recommended to follow the robot vacuum throughout the whole process to remove the items that may affect its work.
- If the robot vacuum may get stuck or scratch the surface of furniture in some areas, you can set restricted areas in the app to prevent the robot vacuum from entering these areas.

How to Use

Starting Vacuuming & Mopping (Installing the mop pad and water tank assembly is required)

1. Before mopping the floor, wet the mop pad and install it properly as illustrated with the velcro straps attached.

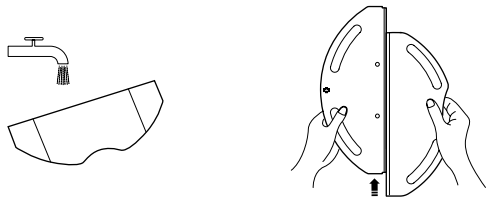

2. Open the water tank lid, add tap water, and cover the water tank lid. Install the mop pad and water tank assembly onto the robot vacuum until you hear a clicking sound. Make sure the assembly is installed in place.

Cautions:

- Do not add liquids such as hot water, detergent, or disinfectant into the water tank to prevent damaging the robot vacuum.
- The functions of the robot vacuum are tested before leaving the factory, so there may be some water residues in it. This is normal.

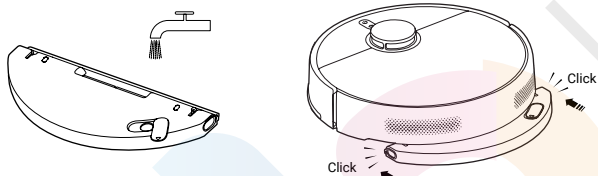

3. Press the button  on the robot vacuum or tap  in the app to start vacuuming and mopping.

Caution: Before mopping, set up virtual walls or restricted areas via the app for the carpeted areas.



4. When the robot vacuum finishes a task and returns to the charging dock, press the water tank release buttons to remove the mop pad and water tank assembly, and then clean the mop pad promptly.

Note: If the robot vacuum will not be used for an extended period, remove the mop pad and water tank assembly and empty it to prevent odor and mildew.

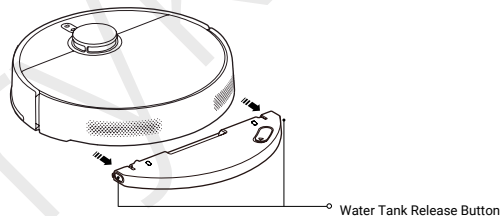

Pausing

When the robot vacuum is running, press any button to pause. Press the button  to resume cleaning.

Note: The robot vacuum will enter sleep mode after being paused or on standby for 10 minutes.

Press any button to wake it up.

Adding Water or Cleaning the Mop Pad

When the robot vacuum is working, you can pause it to refill water or clean the mop pad if needed. Then, reinstall the mop pad and water tank assembly, and press the button  to resume the task.

Docking

During its working, press the button  to pause the robot vacuum, and press the button again to start docking.

When the robot vacuum is in standby mode and not connected to the charging dock, press the button  to start docking.

When a task is completed or its battery is low, the robot vacuum automatically returns to the dock to charge.

Note: Please refer to the app for more functions. Details of each function are subject to the app.

Care & Maintenance

Parts	Cleaning Frequency	Replacement Frequency
Side Brush	Every 2 weeks	3–6 months
Brush	Weekly	6–12 months
Filter	Weekly	3–6 months
Brush Cover	/	3–6 months (or upon wear)
Mop Pad	After each use	3–6 months (or upon wear)

Notes:

- Replacement frequency is for reference only. If a part is damaged, it should be replaced promptly to ensure efficient cleaning.
- Clean and maintain the relevant parts only when the robot vacuum is turned off.

Emptying the Dust Compartment

1. Open the cover of the robot vacuum, and press the dust compartment release button to remove the dust compartment upward from the robot vacuum.
2. Open the dust compartment cover and empty the debris.

Note: Regularly clean the filter to prevent it from becoming clogged.

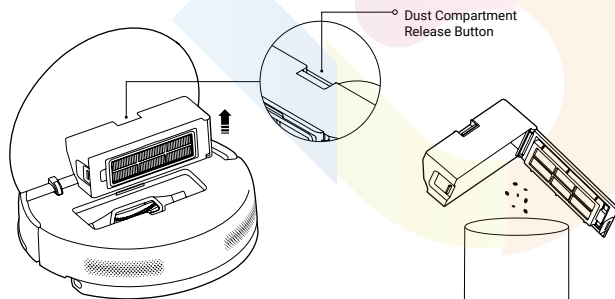

Cleaning the Dust Compartment and Filter

1. Release the filter clip to open the filter and remove it.
2. Rinse the filter and gently tap its edge repeatedly to remove any dirt until it is clean.
3. Open the dust compartment cover, fill the dust compartment with clean water, and clean the dust compartment.
4. Dry the dust compartment and the filter thoroughly before reinstalling them for use.

Notes:

- Do not attempt to clean the filter with a hard object, such as a brush or your fingers.
- Only use clean water to clean the dust compartment and the filter. Do not use detergent.
- Dry the dust compartment and the filter thoroughly before use.

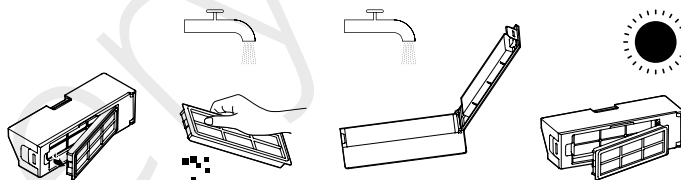

Cleaning the Mop Pad

Remove the mop pad by peeling off the velcro straps, then clean it and dry it thoroughly.

Notes:

- Make sure the mop pad is clean before use, as the mopping performance may be affected if the mop pad becomes too dirty.
- For the best cleaning results, it is recommended to replace the mop pad every 3–6 months.

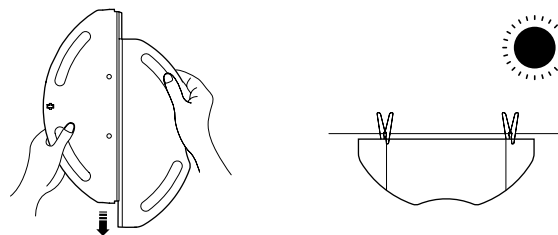

Care & Maintenance

Cleaning the Side Brush and Brush

1. Pull out the side brush upwards.
2. Press the brush cover release buttons to remove the brush cover and take out the brush.
3. Clean the side brush, brush, and comb teeth in the slot.
4. After cleaning, reinstall the brush, brush cover, and side brush in order.

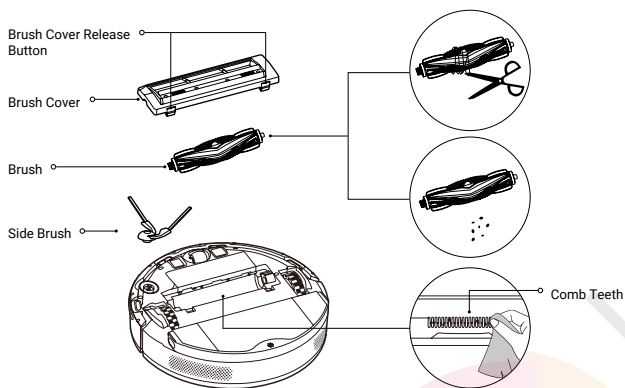

Cleaning Sensors and Charging Contacts

Clean all sensors and charging contacts with a soft cloth every 3 months.

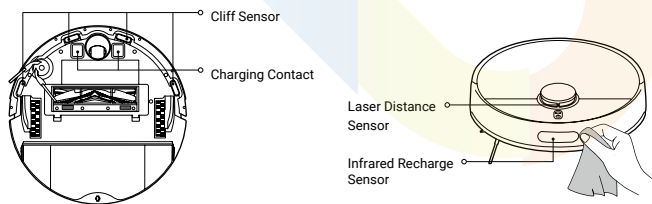

Common Issues

Issue	Possible Cause and Solution
	Check whether the Wi-Fi password is correct.
The robot vacuum cannot connect to Wi-Fi.	The robot vacuum does not support the 5 GHz network frequency band, please connect it to a 2.4 GHz network. The Wi-Fi signal is weak. Make sure the robot vacuum is in an area with good Wi-Fi coverage.
	There is something wrong with the Wi-Fi connection. Reset the Wi-Fi and download the latest version of the Xiaomi Home app, then try reconnecting.
The robot vacuum cannot be turned on.	The battery level is depleted. Please fully charge the robot vacuum before use.
	The ambient temperature is too low or too high. Please use the robot vacuum at an ambient temperature between 0°C and 40°C.
The robot vacuum does not start cleaning.	The battery level is low. Fully charge the robot vacuum and try again.
	The robot vacuum is in DND mode. Make sure it is not in DND mode which will prevent the robot vacuum from resuming cleanup.
The robot vacuum does not resume cleanup.	The robot vacuum is manually returned to the charging dock. Moving it to the charging dock manually, pressing the button on the robot vacuum, or tapping in the app will prevent the robot vacuum from resuming cleanup.
	There are too many obstructions around the charging dock. Place the charging dock in a more open area.
The robot vacuum does not return to the charging dock.	The robot vacuum is too far away from the charging dock. Move it closer to the charging dock and try again.
	Make sure there is enough space around the charging dock; otherwise, the robot vacuum cannot dock onto it for charging.
The robot vacuum does not charge.	Make sure there is no dust or any other obstructions on the surface of the charging contacts.
	Turn off the robot vacuum and then restart it.
The robot vacuum behaves abnormally.	Turn off the robot vacuum and then restart it.
	The robot vacuum cannot perform a scheduled cleanup if it is disconnected from the network. Please make sure the robot vacuum is connected to the network.
The robot vacuum does not perform scheduled cleanups.	Make sure the robot vacuum is not set to DND mode. The DND mode will prevent the robot vacuum from performing scheduled cleanups.
	Make sure the robot vacuum is connected to the network and stays within Wi-Fi coverage at all times.
The robot vacuum keeps going offline.	Make sure the robot vacuum is connected to the network and stays within Wi-Fi coverage at all times.
	Turn off the robot vacuum and check whether the brush, side brush, or drive wheel is entangled with foreign objects. If so, remove foreign objects.
The robot vacuum makes strange noises while cleaning.	Turn off the robot vacuum and check whether the brush, side brush, or drive wheel is entangled with foreign objects. If so, remove foreign objects.
	The dust compartment is full. Clean it and try again.
The robot vacuum no longer cleans efficiently or leaves dust behind.	The filter is blocked. Clean it and try again.
	A foreign object has been caught in the brush. Clean it and try again.

Troubleshooting

When the robot vacuum malfunctions, it may issue voice prompts. Please refer to the information below for timely resolution.

Voice Prompt	Solution
Water tank removed, please reinstall it and try again.	Check and install in place.
Please install the dust compartment	Check and install in place.
The robot vacuum is tilted, please move it to a new location to start.	Reposition the robot vacuum on a level surface and restart it.
Please move the robot vacuum to the charging dock.	Please return the robot vacuum to the charging dock.
The cleaning path is blocked, please clear the surrounding obstacles.	Remove any obstacles around the robot vacuum and restart.
Laser sensor error, please check and clean.	Remove any obstacles or foreign objects and restart. Reposition the robot vacuum and restart.
The robot vacuum is suspended, please move it to a new location to start.	Wipe the cliff sensors clean.
Bumper error, please check if the bumper can rebound properly.	Please remove any foreign objects. If no foreign objects are found, reposition it and restart.

Specifications

Xiaomi Robot Vacuum S40			
Name	Robotic Vacuum Cleaner	Model	OV81
Rated Voltage	14.4 V \approx	Rated Power	70 W
Charging Voltage	20 V \approx	Item Dimensions	Φ 340 × 98 mm
Li-ion Battery	5200 mAh (nominal capacity) 4800 mAh (rated capacity)	Net Weight	4.12 kg
Operation Frequency	2400–2483.5 MHz	Maximum Output Power	< 20 dBm
Wireless Connectivity	Wi-Fi IEEE 802.11 b/g/n 2.4 GHz, Bluetooth 4.2		
Power Consumption	Networked standby mode: \leq 2.0 W	Time to Enter the Condition	Networked standby mode: \leq 20 min

Charging Dock

Model	OV81-CDZ	Rated Input	20 V \approx 1.0 A
Rated Output	20 V \approx 1.0 A	Item Dimensions	130 × 121 × 95 mm
Power Consumption	Standby mode: \leq 0.5 W	Time to Enter the Condition	Standby mode: \leq 20 min

Power Supply

Manufacturer	Zhongshan Baolijin Electronic Co., Ltd.		
Model	BLJ24WJ200100P-V	Average Active Efficiency	\geq 85.47%
Rated Input	100–240 V ~ 50/60 Hz 0.8 A	Efficiency at Low Load (10%)	79.28%
Rated Output	20 V \approx 1.0 A 20.0 W	No-load Power Consumption	\leq 0.10 W

Note: Under normal use of condition, this equipment should be kept a separation distance of at least 20 cm between the antenna and the body of the user.

Manufacturer: Xiaomi Communications Co., Ltd.
Address: #019, 9th Floor, Building 6, 33 Xi'erqi Middle Road,
Haidian District, Beijing, 100085, China
For further information, please go to www.mi.com
User Manual Version: V1.0

EU REP.
Xiaomi Technology Netherlands B.V.
Prinses Beatrixlaan 582, 2595BM, The Hague, The Netherlands
contact@support.mi.com

Importer:
Beryko s.r.o.
Pod Vinicemi 931/2, 301 00 Plzeň
www.beryko.cz



beryko



E-manual QR Code



BHR084AEU-IB