

SENCOR®

SBG 7030BK



SMART CONTACT GRILL

Translation of the original manual



SENCOR®

SBG 7030BK



A

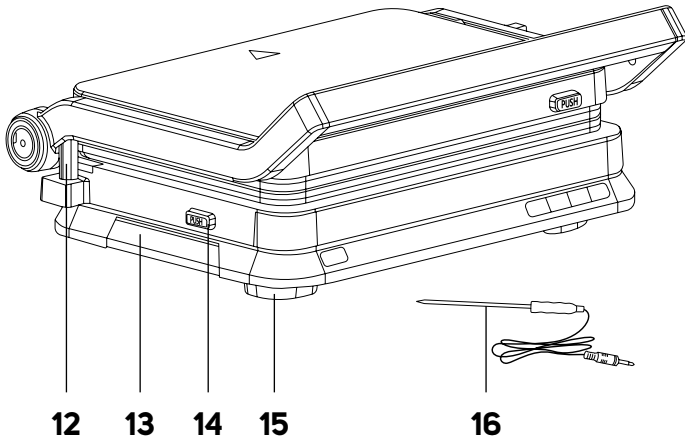
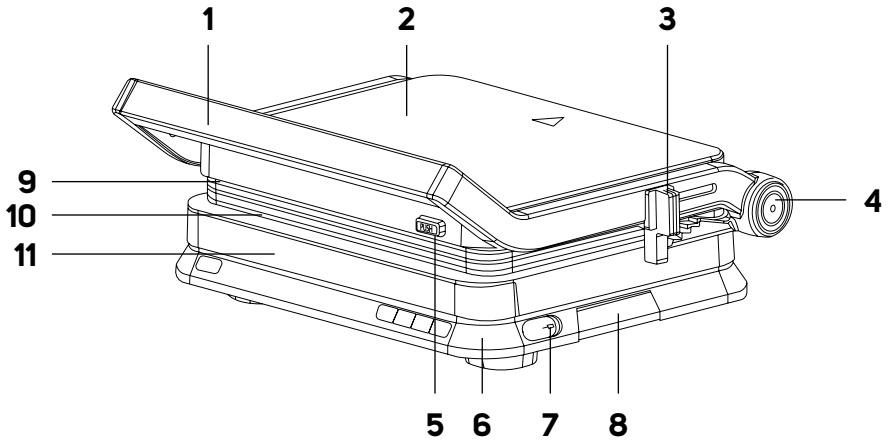

B

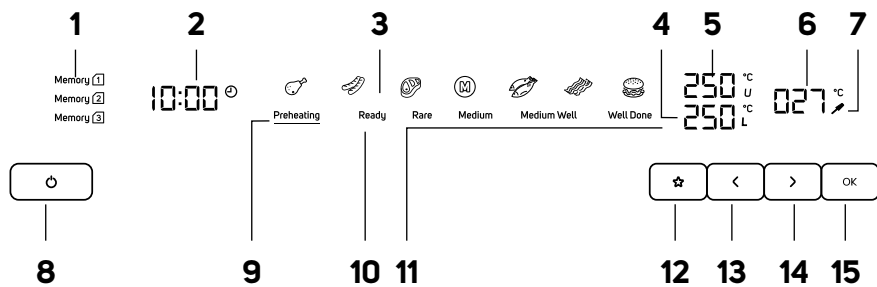

C

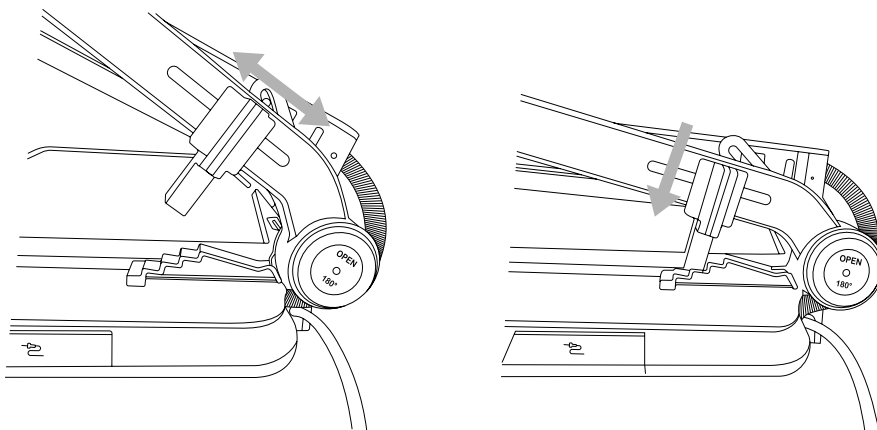

D

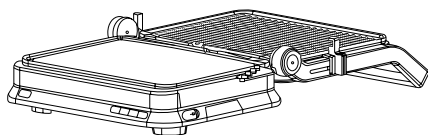
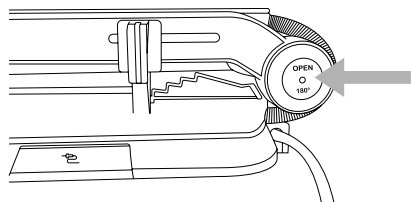

E1

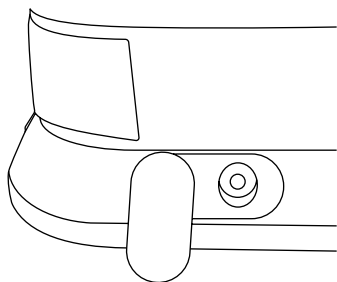

E2

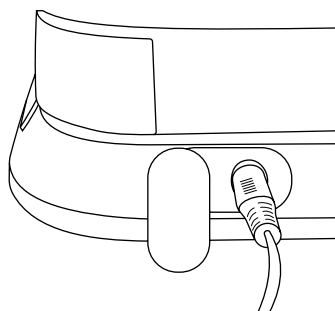

Important Safety Instructions

READ CAREFULLY AND STORE FOR FUTURE USE.

- This appliance may be only used by children aged 8 years and older and by persons with physical, sensory or mental impairments or lack of experience and knowledge, if they are supervised or have been instructed on the safe use of the appliance and understand the potential hazards.
- Children must not play with the appliance.
- Cleaning and user maintenance shall not be done by children unless they are older than 8 years and supervised.
- Children under 8 years of age must be kept away from the appliance and its power cord.
- If the power cord is damaged, have it replaced in a professional service centre in order to prevent a dangerous situation. Never use the appliance if the power cord is damaged.
- Wipe the grill plates with a soft sponge slightly moistened in warm water. Follow the instructions in the “Cleaning and Maintenance” section.
- This appliance is not intended for operation through an external timer switch or a remote control.



Caution: Hot surface

The temperature of accessible surfaces may be higher if the appliance is in operation. Such surfaces can become hot during use. Do not touch hot surface. This could cause skin burns.

Additional important safety instructions for use of the appliance

- Before connecting the appliance to the mains socket, make sure that the nominal voltage indicated on the appliance nameplate matches the voltage of the socket to which you want to connect the appliance.
 - Connect the appliance only to a properly earthed socket. We recommend connecting the appliance to an independent electrical circuit. Do not use extension cords.
 - Do not connect the appliance to a mains socket unless it is properly assembled.
 - Do not touch the power cord or plug with wet hands.
 - This product is designed for household use only. The appliance is also designed for personal use in areas such as:
 - staff kitchenettes in stores, offices and other workplaces;
 - hotel or motel rooms and other living areas;
 - agricultural farms;
 - bed and breakfast establishments.
 - Do not use the appliance in an industrial environment or outdoors.
 - The appliance is designed for food preparation. Do not use it for any other purposes than those intended.
 - Do not place the appliance on windowsills, sink drain trays or unstable surfaces. Always place the appliance on a stable, flat and dry surface.
 - Do not place the appliance on or near an electric or gas stove, do not place it in the vicinity of naked fire or appliances that are sources of heat.
 - Do not use the appliance near a bathtub, sink, swimming pool or other water source.
 - To prevent a risk of electric shock, do not submerge any part of the appliance in water or any other liquid.
 - Before using this appliance, check that the drip tray is located in its place.
 - During operation, sufficient space for air circulation above and on all sides of the appliance should be provided. Do not use the appliance near flammable materials such as curtains, kitchen towels, etc.
 - The temperature of accessible surfaces may be higher if the appliance is in operation. Take care not to touch the hot grill plate or the upper cover. The appliance may remain hot even after being switched off. Before cleaning, maintenance or other manipulation, make sure that the appliance is completely cooled down.
 - Be especially careful when grilling fatty food to avoid being burnt by spluttering fat.
 - Do not touch the grill plate's anti-stick coating with sharp or metallic objects. This may lead to damage.
 - Always switch the appliance off and unplug it from the mains socket when left unattended, after use and before removing the grill plates, cleaning or moving.
 - Allow the appliance to cool before moving, removing grill plates, cleaning or storing. Use the thermally insulated handle for carrying the appliance.
 - Do not use the appliance to support various items.
 - When disconnecting the power cord from the socket, always pull the plug, not the cord. Otherwise, damage to the power cord or the socket could occur.
 - Make sure the power cord does not hang over the edge of a table and that it is not touching a hot surface.
 - Do not use the appliance if it is not working correctly, if it was dropped on the floor, if it is damaged or has been submerged in water.
 - To avoid the danger of injury by electrical shock, do not repair the appliance yourself or make any adjustments to it. All repairs should be carried out by an authorised service centre. Tampering with the appliance may result in the loss of your legal rights regarding faulty performance or warranty for quality.
-

EXPLANATION OF SYMBOLS PLACED ON THE PRODUCT OR IN THE ACCOMPANYING DOCUMENTATION



The product meets all the basic requirements of the applicable EU directives.



This symbol on products or original documents means that used electric or electronic products must not be added to ordinary municipal waste.

- Thank you for purchasing our SENCOR product; we hope it will serve to your satisfaction.
 - Prior to using this appliance, please read the user manual thoroughly, even in cases when you are already familiar with the use of similar types of appliances. Use the appliance only as described in this user manual. Keep the manual for future reference. If you pass the appliance on to another person, ensure that this user manual is included.
 - Carefully unpack the appliance and make sure not to discard any part of the packaging material until you have found all its components. It is recommended to keep the original packaging, packing material, receipt and confirmation of the extent of the seller's liability or warranty certificate at least for the duration of the legal right of defective performance or quality guarantee. When transporting the appliance, we recommend packaging it again in the original box provided by the manufacturer.
1. the upper plate is closed and its height above the lower plate can be adjusted;
 2. the upper plate is tilted to a vertical position; or
 3. the upper plate is fully opened to the same plane as the lower grilling plate (so-called open grill).

Adjusting the Upper Plate Height (Fig. C)

- Lift the upper plate using the handle and move the slider on the right side backwards or forwards to set the desired position of the sliding control. Then carefully fold the upper plate over. It will automatically stop at the desired height.

Lifted Upper Plate

- When using the grill with the plate set in vertical position, it must be lifted all the way up to the stop.

DESCRIPTION OF THE APPLIANCE

A1 Handle	A9 Removable upper ribbed grilling plate
A2 Upper cover	A10 Removable lower flat grilling plate
A3 Sliding control for adjusting the height of the upper plate and grill opening	A11 Control panel
A4 Button to open the grill	A12 Meat thickness sensor (adjusts cooking time accordingly)
A5 Button to release the upper plate	A13 Removable drip tray for juice and fat
A6 Grill base	A14 Button to release the bottom plate
A7 Silicone cover for the grilling probe socket	A15 Grill legs
A8 Storage compartment for the grilling probe	A16 Grilling probe

DESCRIPTION OF THE CONTROL PANEL

B1 Icons of stored favourite programmes (Memory 1–3)	on/off	B9 Preheating icon
B2 Preparation time display	B10 Ready icon	B11 Cooking progress icons (Rare , Medium , Medium Well and Well Done)
B3 Preset programmes icons	B12 ★ button (stored favourite cooking programmes)	B13 < button
B4 Numerical display of the bottom plate	B14 > button	B15 OK button
B5 Numerical display of the upper plate		
B6 Numerical display of the grilling probe		
B7 Connected grilling probe icon		
B8 ⏸ button to switch the grill		

USE

- The Sencor SGR 7030BK contact grill is designed for grilling, gratinating and thermal food preparation. The grill can be opened to allow grilling on both grilling plates.
- It is equipped with a grilling probe that shows the meat temperature, thus facilitating the preparation of your favourite steak.

OPERATING POSITIONS OF THE UPPER GRILLING PLATE

This contact grill can be used with the upper grilling plate in three different operating positions:

Opening the Grill (Fig. D)

Make sure the grill is switched off, cooled and unplugged before opening the grill.

To lift the upper plate into alignment with the lower plate, proceed as follows:

1. When the upper plate is closed or slightly raised above the lower plate, press the OPEN button with one hand and lift the upper plate using the handle with the other hand.
2. Open the upper plate so that the handle rests against the worktop or kitchen counter until the grill opens fully. This creates a double grilling surface.

REMOVAL AND ATTACHMENT OF GRILL PLATES

- Before removing or attaching the grill plates, the grill must be switched off, disconnected from the mains socket and cooled down.
- Each plate has its own release button.
- To release the upper plate, we recommend opening the grill completely so that the upper and lower plates are in the same plane.
- To release the upper plate, press the button on the upper cover on the left side (**A5**). The plate will be released from the lock and then carefully remove it from the upper cover structure.
- To release the lower plate, press the button on the lower cover on the left side (**A14**). Release the plate from the lock and then carefully remove it from the base structure.
- To attach, insert the upper grilling plate into the upper cover so that the tabs at the rear of the cover fit into the rear edge of the plate. Then press the plate against the cover until you hear a click. Attach the lower grilling plate to the base structure in the same manner.



Warning:

Before attaching the grilling plates to the grill, ensure they are clean and completely dry.



Note:

The grilling plates are interchangeable.

BEFORE FIRST USE

- Remove the contact grill from its packaging material and remove any promotional materials, including labels that may be placed on the grill plates.

- Wipe the grill plates with a clean, slightly damp cloth and then wipe dry.
- Remove the drip tray from the base. Wash it in warm water with a little kitchen detergent, rinse and wipe dry. Put it back in place.
- Wipe the outer surface of the grill with a slightly damp, soft cloth and then wipe dry.



Warning:

Never rinse the grill and/or power cord under running water or submerge in water or another liquid.



Note:

It is recommended to turn the grill on to the highest temperature before first use and leave it running for about 5 minutes to burn the grill and grill plates and remove any unpleasant odour during the first use. During this time, you may also notice slight smoke. This is normal.

GRILL PLACEMENT

- Place the grill on a flat, firm and stable surface well away from the mains socket.
- Make sure there is clear space around the grill for hot air extraction and handling.
- Ensure that there are no heat-sensitive objects in the vicinity.
- Place the grill well away from combustible materials such as curtains, dish towels, etc.
- Do not place the grill on fabric-covered surfaces.

COMMISSIONING

- Fully unwind the power cord.
- Plug the power cord plug into a power outlet and a beep sounds.

USING YOUR CONTACT GRILL

Preset Preparation Programmes

1. Ensure that both grilling plates are properly fitted and the drip tray is properly inserted.
2. Press the \odot button and the control panel will illuminate.
3. Use the \langle / \rangle buttons to select one of the preset preparation programmes.
4. Press the **OK** button to start preheating. The display will flash **"Preheating"** and the backlight will turn pink. Let the grill preheat.
5. Once the grill is preheated, three beeps will sound and the backlight will turn green. **"Ready"** will flash on the display.
6. Open the grill and place the food you wish to cook on the bottom grilling plate, then close the top plate.
7. Press the **OK** button. The countdown of the preset preparation time starts. As the food cooks, the doneness level will flash and subsequently illuminate: **Rare, Medium, Medium Well** and **Well Done**. The backlight colour will also change as the doneness level changes.
8. Remove the food when your desired degree of doneness appears on the display. Open the grill and remove the food.
9. Once the set cooking time has elapsed, six beeps will sound, the grill will stop heating and switch to standby mode.
10. Open the grill and remove the food from the grilling plate using wooden or heat-resistant plastic kitchen utensils.



Warning:

To open the grill, always use the thermally insulated handle.

11. After finishing use, press the \odot button. Unplug the power cord from the power socket.

12. Prior to cleaning, maintenance or other handling, let the grill cool down.

If you select steak preparation, each achieved degree of doneness is accompanied by a beep. For other cooking programmes, the beeping is disabled.



Warning:

During use, the grill plates and outer surface of the grill become hot and may reach high temperatures. The grill remains hot even after use. Mishandling may lead to serious burns. Take extra care when handling the grill. We recommend using kitchen mitts. Always use the available thermally insulated handle.



Note:

Never use metal utensils or knives as they may scratch grill plate's anti-stick coating.

Manual Preparation

1. Ensure that both grilling plates are properly fitted and the drip tray is properly inserted.
2. Press the \odot button and the control panel will illuminate.
3. Use the \langle / \rangle buttons to select manual preparation. "M" will flash on the display.
4. Press the **OK** button and the temperature will flash on the display.
5. Use the \langle / \rangle buttons to set the desired temperature. You can adjust the temperature both during preheating and during cooking.
6. Press the **OK** button to start preheating. The display will flash **"Preheating"** and the backlight will turn pink. Let the grill preheat.
7. Once the grill is preheated, three beeps will sound and the backlight will turn green. **"Ready"** and the preparation time will flash on the display.
8. Use the \langle / \rangle buttons to set the preparation time. You can adjust the cooking time both during preheating and during cooking.



Note:

The grill can also be used without a cooking time set. When the grill is started, a 2-hour timer will start.

9. Open the grill and place the food you wish to cook on the bottom grilling plate, then close the top plate.
10. Press the **OK** button and the countdown of the set cooking time will begin. As the food cooks, the doneness level will flash and subsequently illuminate: **Rare, Medium, Medium Well** and **Well Done**. The backlight colour will also change as the doneness level changes.
11. Remove the food when your desired degree of doneness appears on the display. Open the grill and remove the food.
12. Once the set cooking time has elapsed, six beeps will sound, the grill will stop heating and switch to standby mode.
13. Open the grill and remove the food from the grilling plate using wooden or heat-resistant plastic kitchen utensils.



Warning:

To open the grill, always use the thermally insulated handle.

14. After finishing use, press the \odot button. Unplug the power cord from the power socket.
15. Prior to cleaning, maintenance or other handling, let the grill cool down.

Preset Programmes Preparation Table

Mode	Default Temperature
Chicken strips	230 °C
Sausages, hotdogs	220 °C
Steak	230 °C
Fish	230 °C
Bacon	210 °C
Hamburger	190 °C
Manual Preparation	250 °C

- The preparation time for individual programmes is influenced by, among other things, the thickness of the meat or food to be roasted.
- For the Steak programme, the total preparation time is not displayed, but rather the preparation time for the given degree of doneness. When the desired degree of doneness is reached, a beep sounds and the digital display starts a new preparation time for the next degree of doneness.

Temperature Setting

The grill is closed

- When the grill is closed (the upper plate is lowered onto the lower plate), you set the same temperature for both plates. The temperature setting procedure is the same as described in point 5 of the manual preparation above.

The grill is open

- When the upper plate is lifted or the grill is open, you will be able to set the temperature for each grilling plate separately. Follow these steps:
 1. After selecting manual preparation, the numerical temperature display of the upper plate will start flashing.
 2. Use the </> buttons to adjust the temperature of the top plate.
 3. Press the **OK** button and the numerical temperature display of the bottom plate will start flashing.
 4. Use the </> buttons to adjust the temperature of the bottom plate.
 5. Press the **OK** button to start preheating.
- If you close the grill whilst setting the temperature, the temperature will revert to default and you will need to set the temperatures again.
- After starting the preheating, you can close the grill (lower the upper plate) to accelerate the preheating process without changing the temperature settings.

Using the Grilling Probe

1. Release and lift up the silicone cover of the socket on the side of the grill – see figure **E1**.
2. Connect the grilling probe connector to the socket – see figure **E2**.
3. Insert the grilling probe into the piece of meat you are going to grill.
4. Turn on the grill, select a preset cooking programme or manual cooking. The grilling probe icon will illuminate on the display.
5. The numerical display will show the temperature inside the meat. This allows you to easily determine how well the meat is cooked.
6. After completing the preparation, remove the probe from the meat and wipe it with a slightly dampened cloth.
7. If you are not using the probe, disconnect it from the grill.

Favourites Option

- The Favourites option allows you to save settings (programme, temperature and cooking time) to the grill's internal memory. You can save up to 3 settings.

Storage:

1. Upon completion of preparation, press the Favourites button and "Memory 1" will illuminate.
2. Press the **OK** button and the settings will be saved to memory position 1.
3. Repeat the same procedure to save settings to "Memory 2" and "Memory 3".

If you have already saved three settings and want to save another setting, the setting stored in memory position 1 will be overwritten.

Favourites Preparation

1. Turn on the grill, repeatedly press the Favourites button and select the saved setting.
2. Press the **OK** button to start preparation according to the saved setting.

Pausing the Cooking Process

- If you press the **OK** button during the preheating or grilling process, the preparation process will be interrupted. Press the **OK** button again to resume the preparation.

Canceling the Preparation

- If you press and hold the **OK** button for 2 seconds during the preheating or grilling process, the preparation process will be cancelled and the grill will switch to programme selection mode.

Automatic Shut-off

- If you select a preparation programme (or set manual preparation) but do not press the **OK** button to turn on the grill, after 15 minutes of inactivity, three beeps will sound and the grill will automatically switch off.

TIPS FOR GRILLING MEAT AND SAUSAGES

- For optimum results, cut the meat into evenly thick slices.
- In order to prevent the meat from being tough and dry, we recommend to avoid salting before grilling. We recommend seasoning the meat with salts or spices only after thermal processing.
- Before grilling marinated meat, use paper towels to dry excess marinade. Some marinades may contain large amounts of sugar, which may then burn.
- During grilling, do not prick the meat to avoid juice flowing out and meat being stiff and dry.
- Do not dry out the meat by grilling it for too long.
- Always make sure that chicken meat is thoroughly cooked.
- You need not prick pre-cooked sausages before grilling.
- Using the contact grill for grilling meat with heavy bones, such as T-bone steaks, is not recommended.
- The food must be completely thawed before frying.

CLEANING AND MAINTENANCE

- Clean the grill after each use. Before cleaning, the grill must be switched off, unplugged and completely cooled.



Warning:

To prevent the risk of electric shock, do not immerse the appliance, power cable, or plug into water or any other liquid.

Grill plates

- To clean the grill plates, use a paper kitchen towel or a dampened soft cloth.
- In case of heavier soiling, clean the grill plates with a slightly dampened cloth with a small amount of neutral kitchen detergent. After applying the detergent, thoroughly wipe the plates with a clean, slightly dampened cloth and dry them completely.



Note:

The grill plates are easier to clean when they are still lukewarm. For easier handling, you may remove the plates from the grill body before cleaning. However, always ensure that they have completely cooled down.

Drip Tray

- Make sure the contents of the drip tray have cooled down and then carefully remove it from the base.
- Empty its contents and wash it in warm water with the addition of neutral kitchen detergent. Then rinse it with clean water, dry it and put it back in place.

Grilling Probe

- After removing from the meat, wipe the probe with a slightly damp cloth. Wipe it with a dry cloth. Allow the probe to cool before storing.
- Store the cooled and clean grilling probe in the compartment on the side of the grill.

External Surface

- To clean the exterior surface, use dry or slightly dampened cloth. Then wipe everything dry.
- Never use wire cloths, abrasive cleaners, petrol, etc. for cleaning.

Storage

- If the appliance will not be used for an extended period, unplug it from the power socket, let it cool down, and clean it following the instructions provided above.
- Before storing, ensure that the appliance and all accessories are thoroughly clean and dry.
- Store the appliance in a dry, clean, and well-ventilated place away from extreme temperatures and out of the reach of children or pets.

.....

TECHNICAL SPECIFICATIONS

Rated voltage range	220–240 V~
Rated frequency.....	50-60 Hz
Rated power input.....	1800–2100 W
Power consumption in off mode	0.42 W
Time needed for the equipment to reach the applicable off mode ...	0 second

.....

INSTRUCTIONS AND INFORMATION ON DISPOSAL OF USED PACKAGING MATERIAL

Dispose of used packaging material at the designated municipal waste disposal site.

DISPOSAL OF USED ELECTRICAL AND ELECTRONIC EQUIPMENT

Used electrical and electronic products must not be disposed of in ordinary municipal waste. To enable the proper disposal and recycling of these products, deliver them to the designated collection points. Alternatively, in some European Union states or other European countries the products can be returned to the local retailer when buying an equivalent new product. By properly disposing of this product, you help preserve valuable natural resources and help to prevent potential damage to the environment and human health resulting from improper waste disposal. For more details, contact your local authority or nearest collection point. Fines may be imposed for improper disposal of this type of waste as per national regulations.

For business entities in European Union States

To dispose of electric or electronic equipment, request the necessary information from your retailer or supplier.

Disposal in other countries outside the European Union

To dispose of this product elsewhere, request the necessary information on the correct disposal method from local authorities or your retailer.

.....

Changes to text and technical parameters are reserved.