



# CREATOR™



EXPERT

10269



Booklet available in English on  
Heft in deutscher Sprache erhältlich auf  
Livret disponible en français sur  
Libretto disponibile in italiano su  
Folheto disponível en español en  
Folheto disponível em português em

A füzet magyarul ezen a honlapon olvasható:  
Buklets latviešu valodā pieejams vietnē  
如需中文版手册, 请访问

[LEGO.com/creatorexpert](http://LEGO.com/creatorexpert)



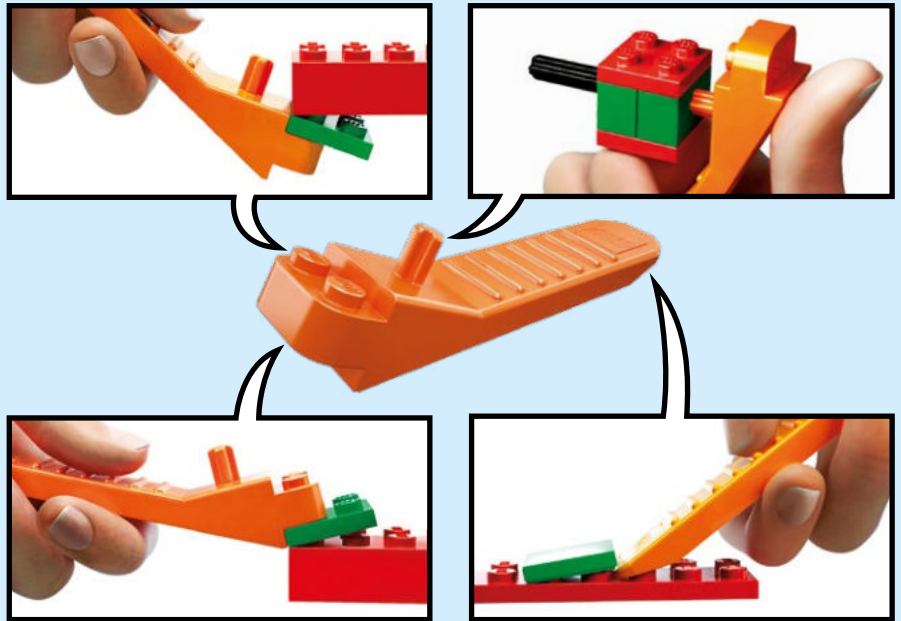

[LEGO.com/brickseparator](https://LEGO.com/brickseparator)



**1** Download the LEGO® Life App  
 Lade dir die LEGO® Life App herunter  
 Télécharge l'application LEGO® Life  
 Télécharger l'application LEGO® Life  
 Scarica l'app LEGO® Life  
 Descarga la app LEGO® Life  
 Descarrega a App LEGO® Life  
 Töltsd le a LEGO® Life Appot!  
 Lejupielādē lietotni LEGO® Life  
 下载 LEGO® Life 应用程序



**2** Scan the code on the front cover  
 Scanne den Code auf der Titelseite  
 Scanne le code sur la page de couverture  
 Scanner le code sur la page couverture  
 Scansiona il codice sulla copertina  
 Escanea el código de la portada  
 Faz scan do código na frente da capa  
 Olvasd be a borítón látható kódot!  
 Noskenē kodu uz priekšējā vāka  
 扫描封面上的二维码



**3** Get the Building Instructions  
 Hol dir die Bauanleitung  
 Obtens les instructions de montage  
 Obtenir les instructions de montage  
 Scarica le istruzioni per la costruzione  
 Consulta las instrucciones de construcción  
 Obtém as Instruções de Construção  
 Szerezd be az építési útmutatókat!  
 Saņem būvēšanas instrukcijas  
 获取拼搭说明

**LEGO.com/apps**

Check for compatibility  
 Kompatibilität prüfen  
 Vérifier la compatibilité  
 Controlla la compatibilità  
 Comprueba tu compatibilidad

Verificar a compatibilidade  
 Ellenőrizd a kompatibilitást  
 Pārbaudīt saderību  
 检查兼容性



# THE HARLEY-DAVIDSON STORY





Founded in 1903, Harley-Davidson is one of the world's largest manufacturers of motorcycles, as well as a globally recognized lifestyle brand with a loyal following. Started in a shed in Milwaukee by William S. Harley and brothers Arthur and Walter Davidson, Harley-Davidson is also the oldest continuously running motorcycle manufacturer in the world. As a brand, it is as durable as the motorcycles it creates, adapting to many challenges along the way to be a world leader in motorcycling and a symbol of the American dream.

The history of the company is intertwined with the history of the USA, which is why Harley-Davidson is referred to as the "American motorcycle." By 1920, Harley-Davidson was already being sold in 67 different countries, via 2,000 dealers worldwide. During the First and Second World Wars, the company also played a crucial role in supplying vehicles to the American

military which resulted in the business expanding after the war. In the years after, product development expanded into both lightweight and smaller twin-cylinder models. The introduction of the *Sportster*® motorcycle in 1957, along with other models, gave the brand a name in nimble and powerful machines for racing, road trips and much more.

Over time, the company has become well-known for its cruisers, including the iconic *Harley-Davidson*® *Fat Boy*®, a beautifully designed V-twin engine motorcycle with a *Softail*® frame and solid-cast disc wheels. Stylish, comfortable and reliable, the *Fat Boy*® motorcycle is one that you could ride almost anywhere. Harley-Davidson continues to be true to its past, as it embraces the future.

We're pleased to present our LEGO® tribute to this American icon.

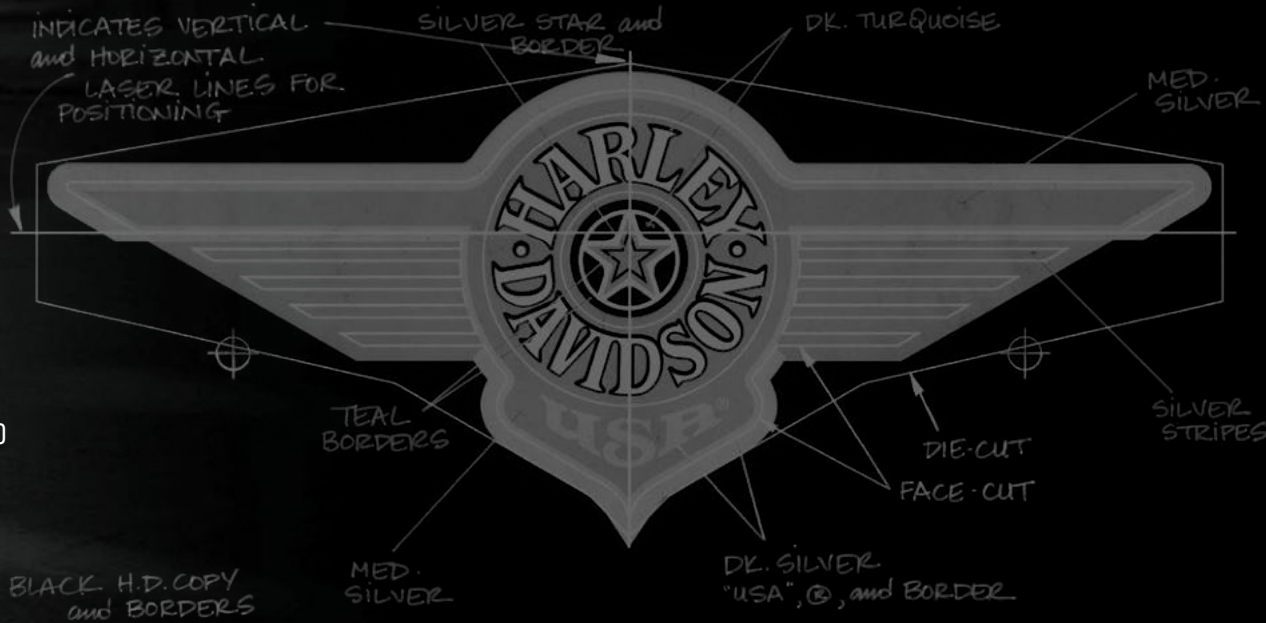

The Harley-Davidson logo designed for the original 1990 *Fat Boy*®

# RIDING THROUGH TIME...



Milwaukee, Wisconsin - William Harley and brothers Walter and Arthur Davidson sell their first single-cylinder motorcycle.



The founders create the first factory-sponsored motorcycle racing team, that became known as the "Wrecking Crew"™ race team.



At the end of the First World War, more than 20,000 Harley-Davidson® military motorcycles were used for the military.



The model EL or "61," otherwise known as the Knucklehead is released; it would inspire several elements of the Fat Boy® motorcycle. H-D is one of only two American motorcycle makers to survive the Great Depression.



The XL Sportster® model is introduced.

1903

1909

1914

1916

1918

1936

1941

1945

1957



Harley-Davidson introduces its first V-twin engine.

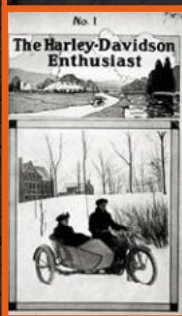

The magazine "The Harley-Davidson Enthusiast" was launched and went on to be the longest-published motorcycle magazine in history.



Harley-Davidson manufactures more than 80,000 motorcycles for use by the U.S. Military and its allies during WWII.



# ...HARLEY-DAVIDSON ACROSS THE YEARS



Thirteen members of Harley-Davidson's senior management team purchase the company from AMF in a leveraged buyout, known as the 'Buyback'.

1971



The all new model FX *Super Glide*® motorcycle is unveiled. Remembered as the first factory-custom motorcycle, the *Super Glide*® motorcycle combined the engine and chassis of a big twin with a light, nimble front fork.

1981



Introduction of the *Evolution*® V-twin engine and the debut of the first *Softail*® model.

1984

Harley-Davidson returns to public ownership, with stock trading at \$11 per share at its IPO.

1986



The *Fat Boy*® motorcycle is introduced

1990

The *V-Rod*® model, equipped with Harley-Davidson's first-ever liquid-cooled engine for street use, is released.



2003

The project *LiveWire*™ model becomes the first electric motorcycle prototype to be unveiled by a major manufacturer.



The 115th anniversary and total redesign of the *Softail*® family. The new *Softail*® model fuses the classic *Harley-Davidson*® "hard-tail" look with all-new chassis, *Milwaukee-Eight*® engine and monoshock rear suspension.

2008

The 105th anniversary and the opening of the new *Harley-Davidson Museum*® site. Instead of the traditional ribbon-cutting, the museum is unveiled with a 'chain-cutting', a large collection of motorcycle chains sliced using a blowtorch.

2001



The H-D Motor Company celebrates its 100th anniversary with a year-long, worldwide birthday celebration. More than 250,000 people venture to Milwaukee for the final stop of the Open Road Tour...the party!

2014 2017-18



The first Harley-Davidson production of the electric motorcycle, *LiveWire*™, will launch in 2019. It will be the first in a broad portfolio of electric two-wheelers.

2019



# THE *FAT BOY*® MOTORCYCLE - 25 YEARS OF AN AMERICAN ICON



Designed by Willie G. Davidson and Louie Netz in 1990, the *Harley-Davidson*® *Fat Boy*® motorcycle is one of the company's most iconic and popular models. It is nicknamed 'The Legend', due to it being a timeless, dependable and powerful motorcycle.

The name *Fat Boy*® motorcycle gave a nod to the motorcycle's predecessor, the *Fat Bob*® motorcycle and its large personality. With a V-twin *Softail*® cruiser, what characterizes the *Fat Boy*® motorcycle is its solid-cast front and rear disc wheels, shotgun exhausts and gently flared fenders. The original model from 1990 sported monochrome silver paint and a silver frame with yellow detailing, which together with the lacing on the seat and fuel tank gave the motorcycle a handcrafted look. The *Fat Boy*'s logo was also an iconic design, evoking good-willed patriotism and nostalgia, and can still be found on *Fat Boy*® model designs today.

But it wasn't just a one and done design. The *Fat Boy*® motorcycle underwent rigorous testing and customer feedback for two years before it was deemed ready to ride. In fact, Willie G. rode a prototype of the

*Fat Boy*® motorcycle to Daytona in 1988 and 1989, both trips helping him to improve the bike's design.

In 2010, the *Fat Boy*® Lo motorcycle was introduced, featuring the lowest seat height on any *Harley-Davidson*® motorcycle, and advertised as a "darker, lower, meaner" version of the original.

Since its release, the *Fat Boy*® motorcycle has experienced some changes, particularly in the *Softail*® model redesign in 2017. However, even with these changes, Harley-Davidson has retained iconic design elements from the original 1990 *Fat Boy*® motorcycle.

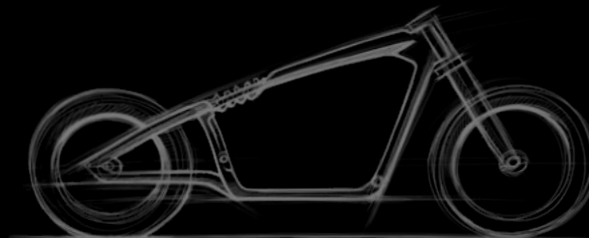



# DESIGNING THE LEGO® HARLEY-DAVIDSON® FAT BOY® MOTORCYCLE



A WORD FROM

**MIKE PSIAKI**

LEGO® SENIOR DESIGNER



## THE CHALLENGE OF MAKING IT IN BRICKS

"LEGO® bricks are great for building square houses and rectangular structures that are not meant to move. Motorcycles are not square, and they're supposed to move, so from the start everything was a challenge! The frame was probably the biggest challenge because it is made mostly out of triangles and is very thin. It was difficult to make something that matched the real *Fat Boy*® motorcycle's *Softail*® frame, but also had the strength needed to support the model in play. For the final design, we used a hybrid combination of LEGO Technic™ and System Elements to create a model that is both rugged and beautiful, while delivering a one-of-a-kind building experience; a true feat of LEGO engineering."

## OUR APPROACH

"We wanted to build a working engine from LEGO system elements for this motorcycle and create the frame and motor so that both would be strong and reliable. Overall, we made several different major loops on the model to make sure everything was working from a functional perspective, a stability perspective and an aesthetic perspective. Most importantly, we wanted to deliver all that in an incredible building experience, the core of what makes a LEGO model cool."

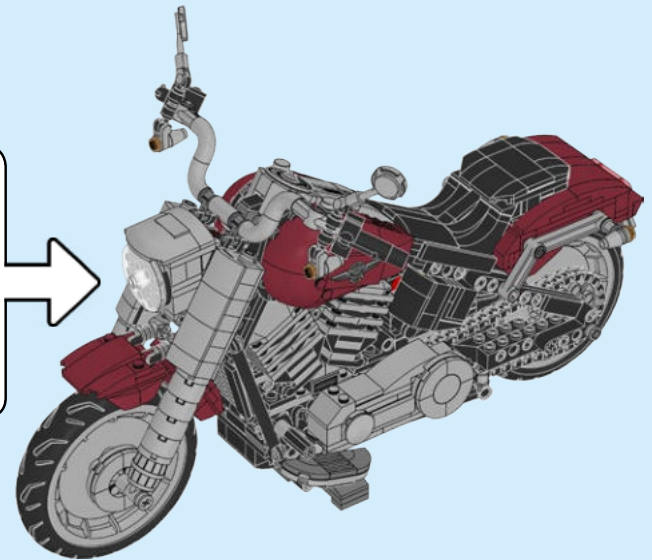
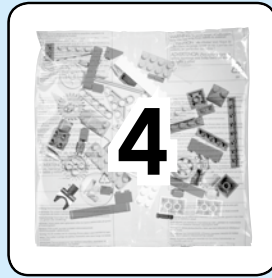
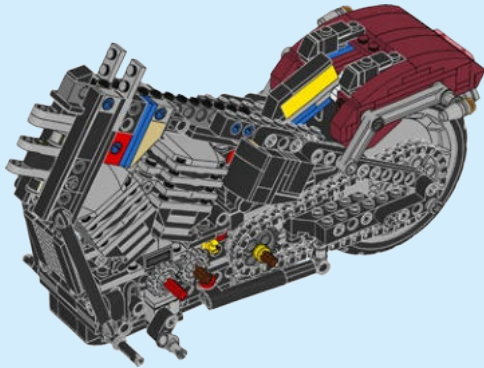
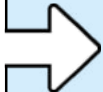
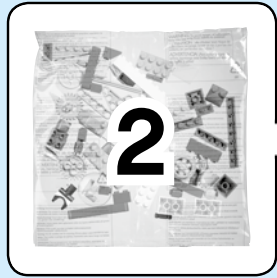
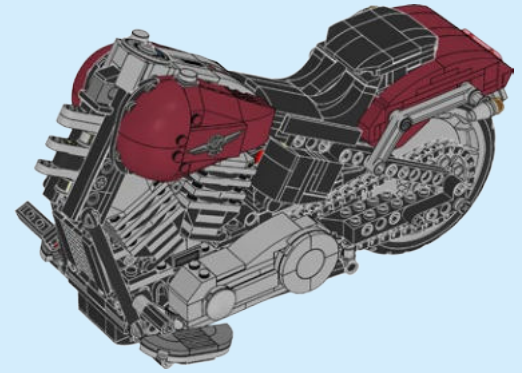
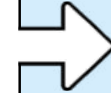
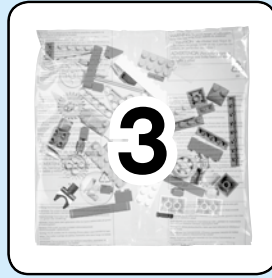
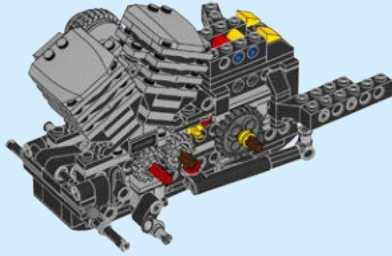
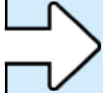
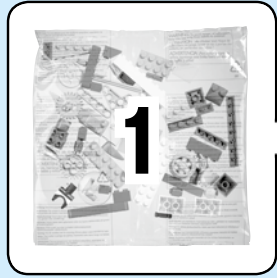



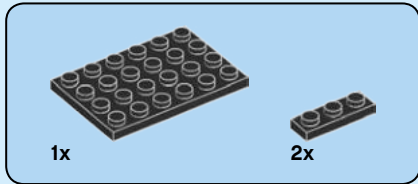
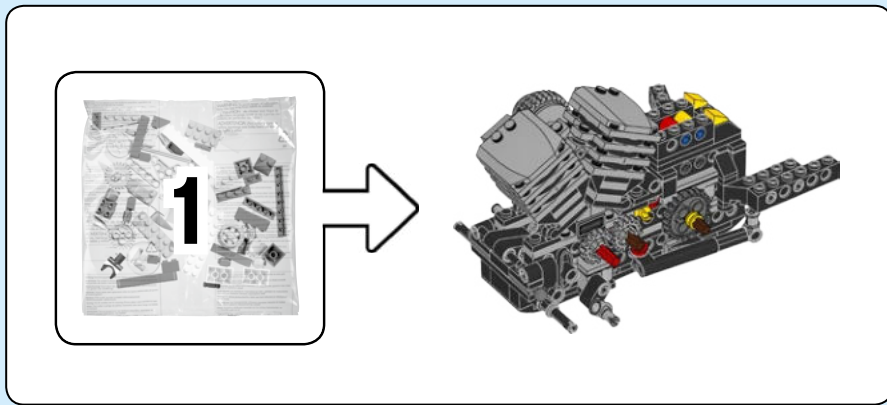

1

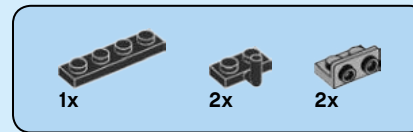
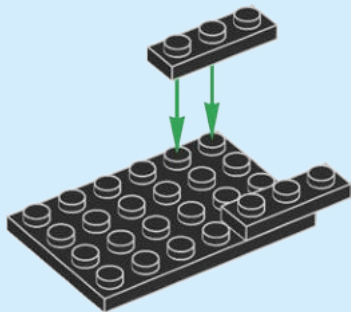

2

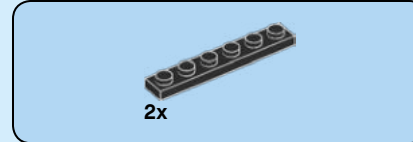
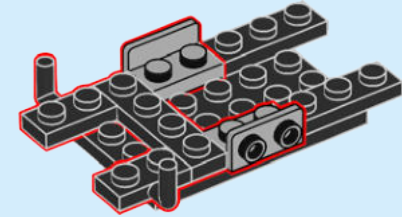

3

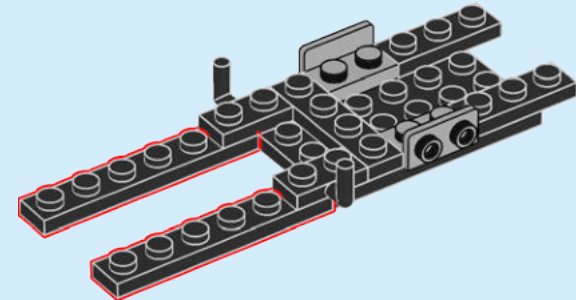

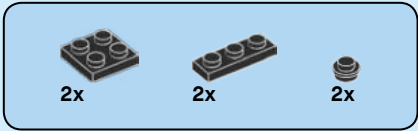

4

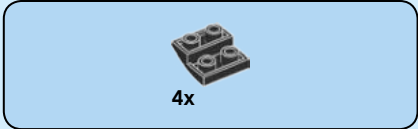
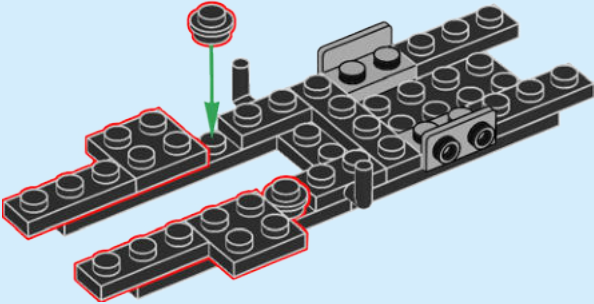

5

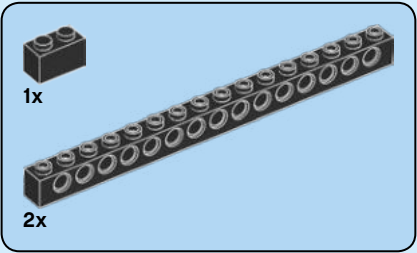
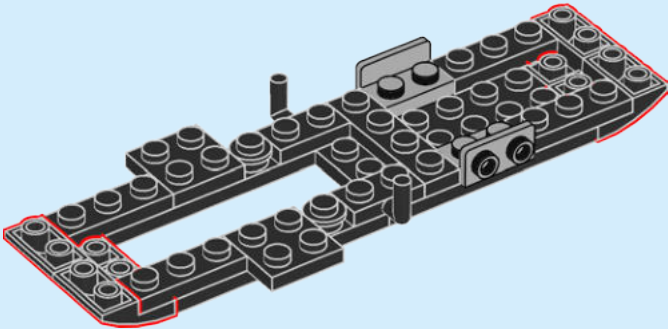

6

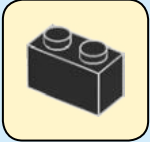
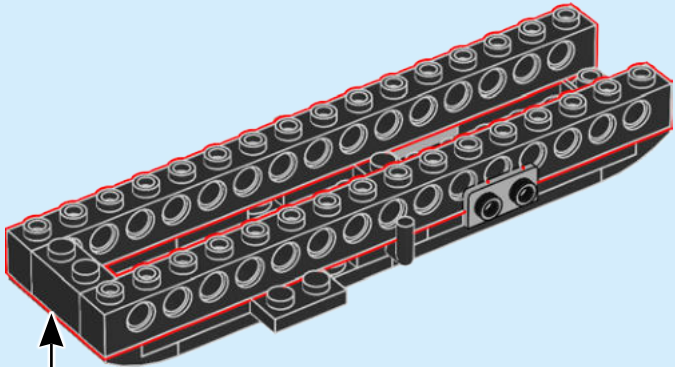



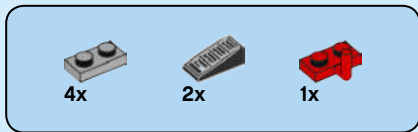

7

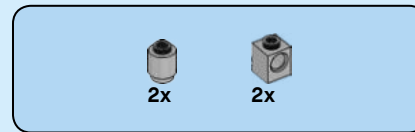
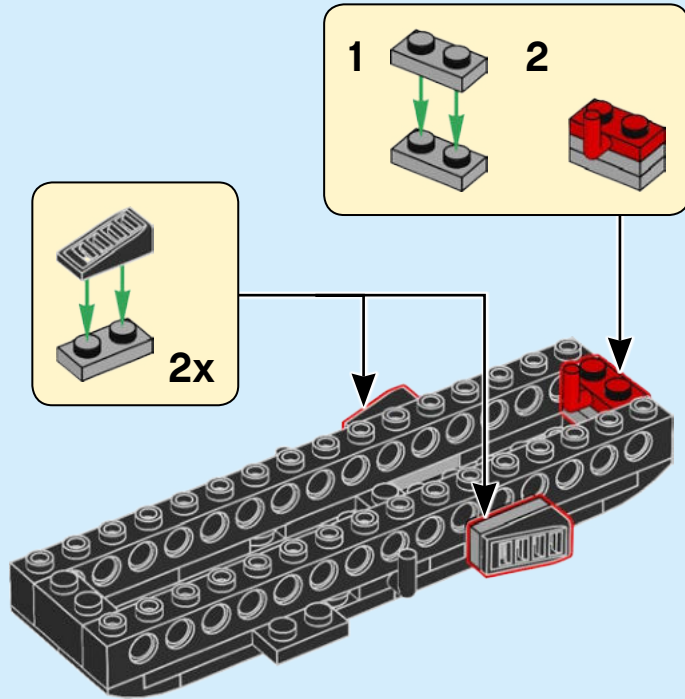

8

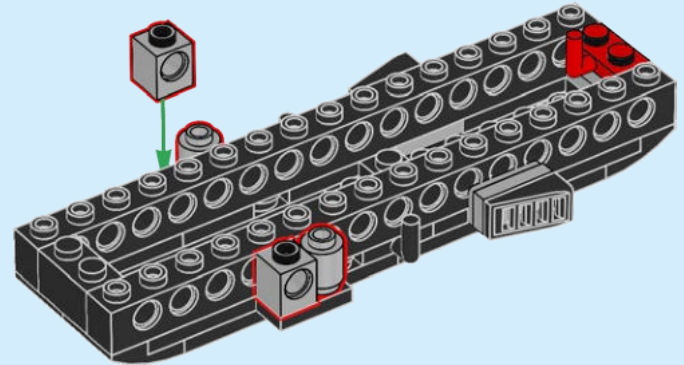

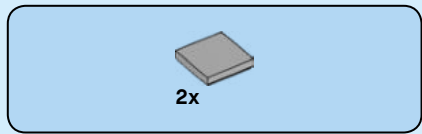

9

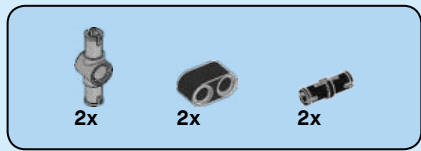
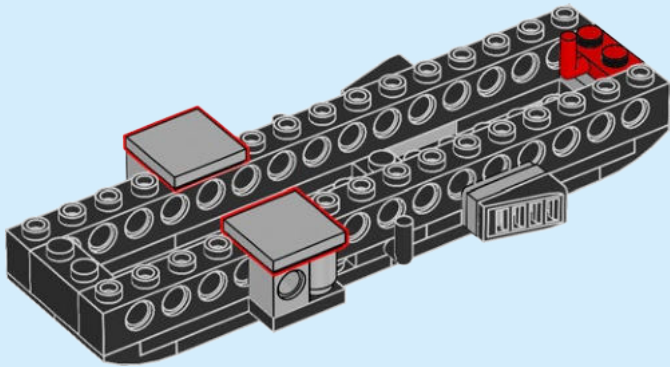

10

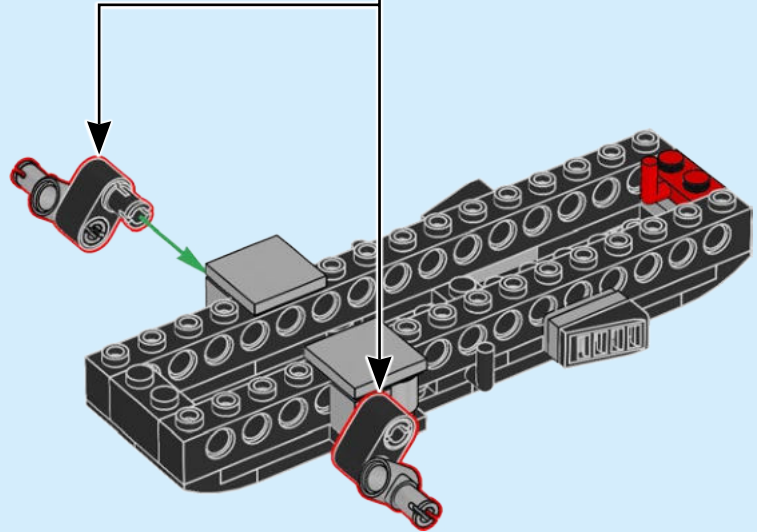
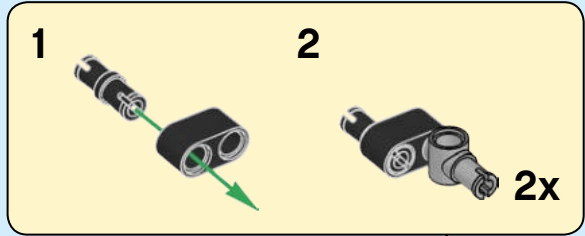



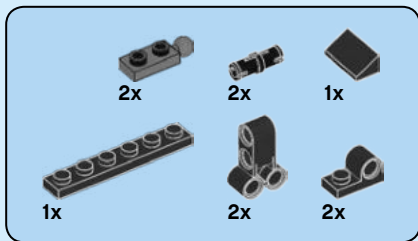

11

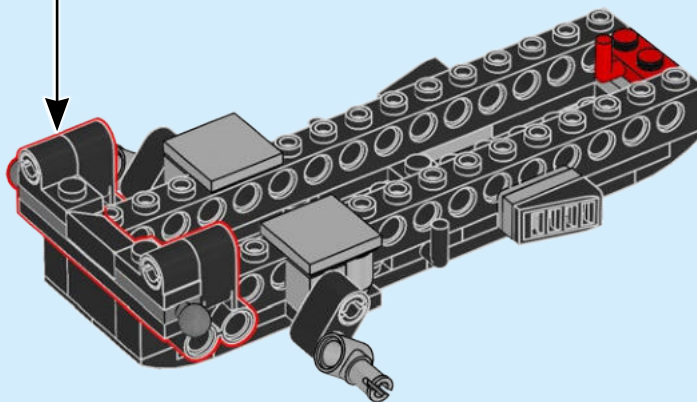
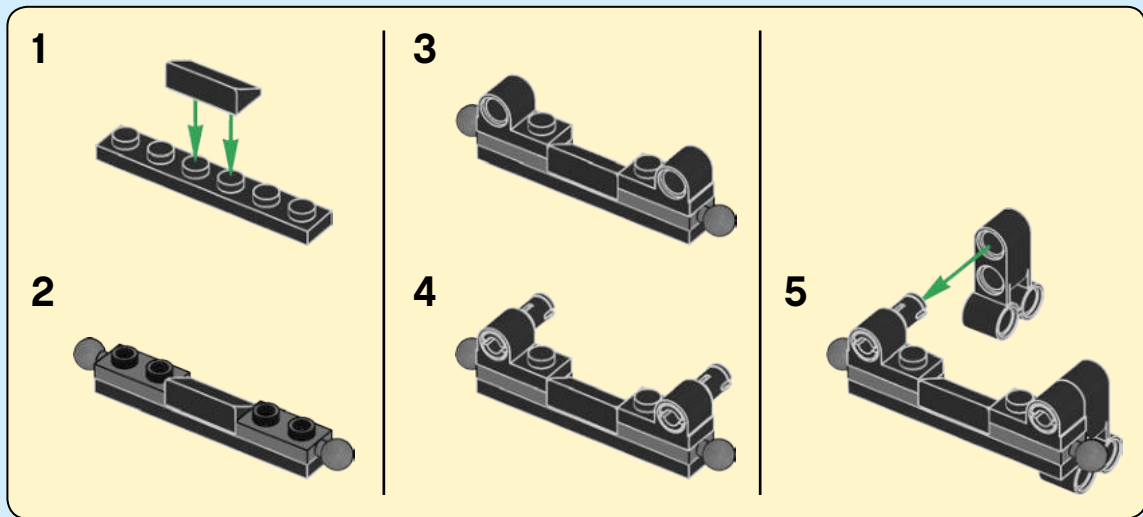

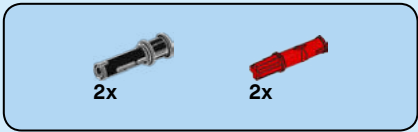

12

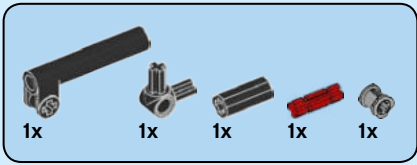
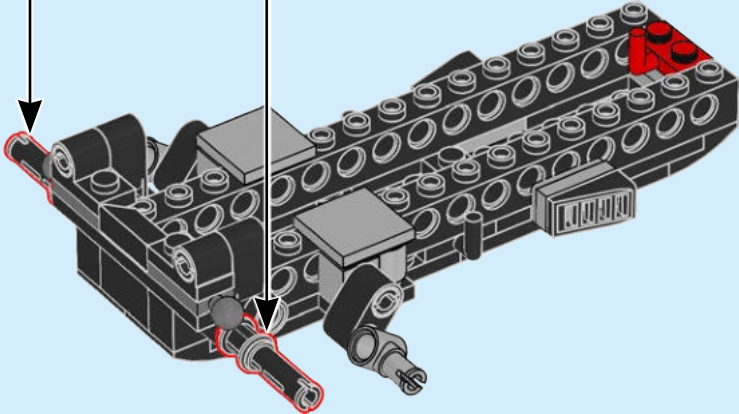
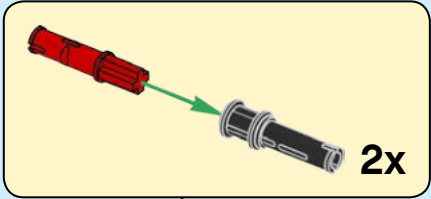

13

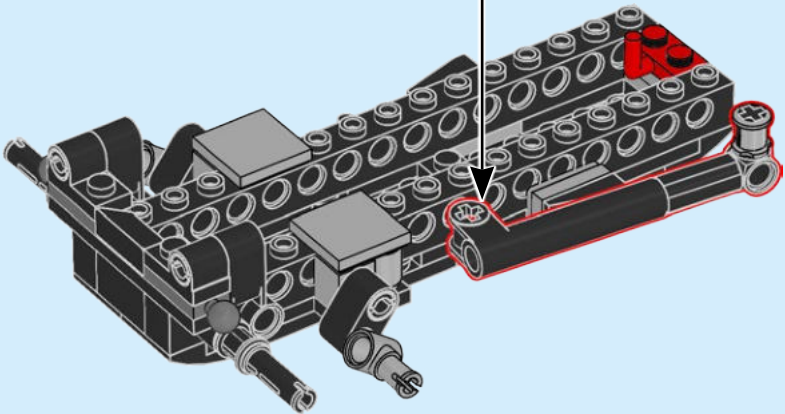
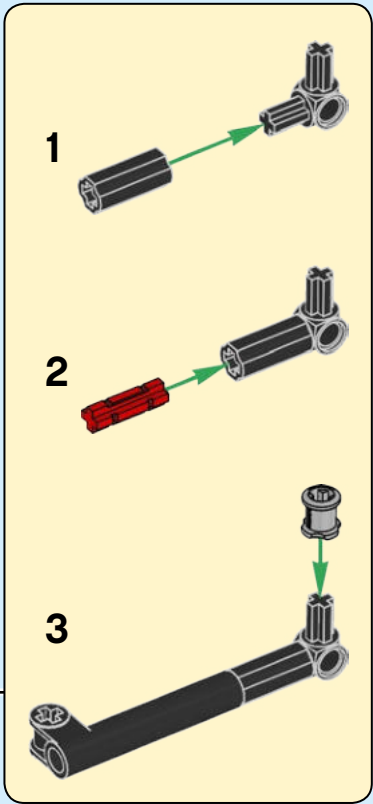





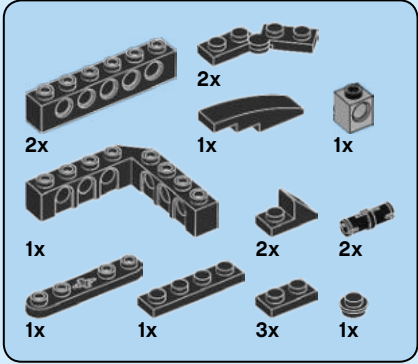
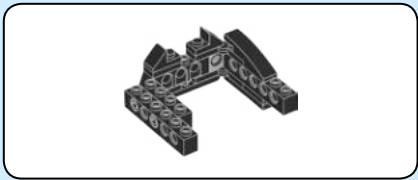

# 16

1

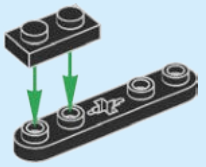

2

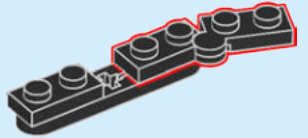

3

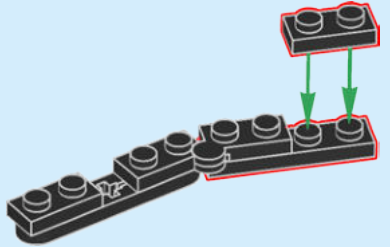

4

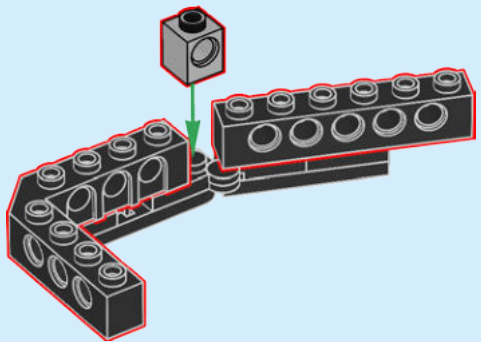

5

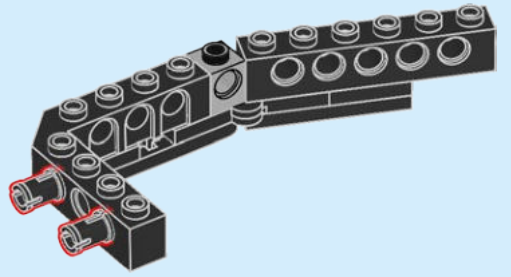

6

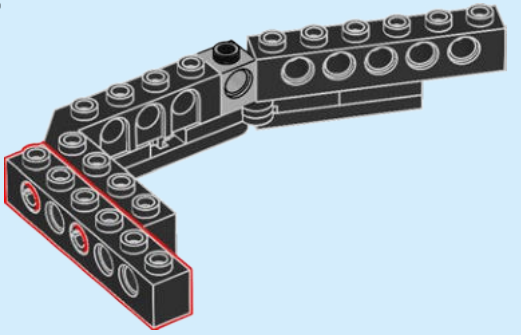

7

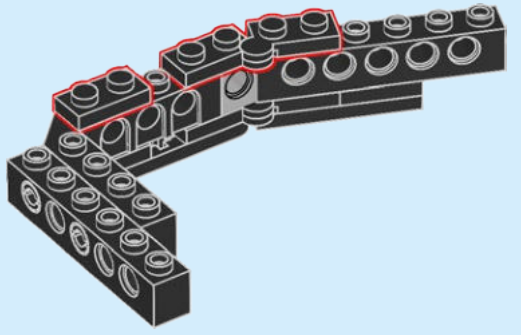



8

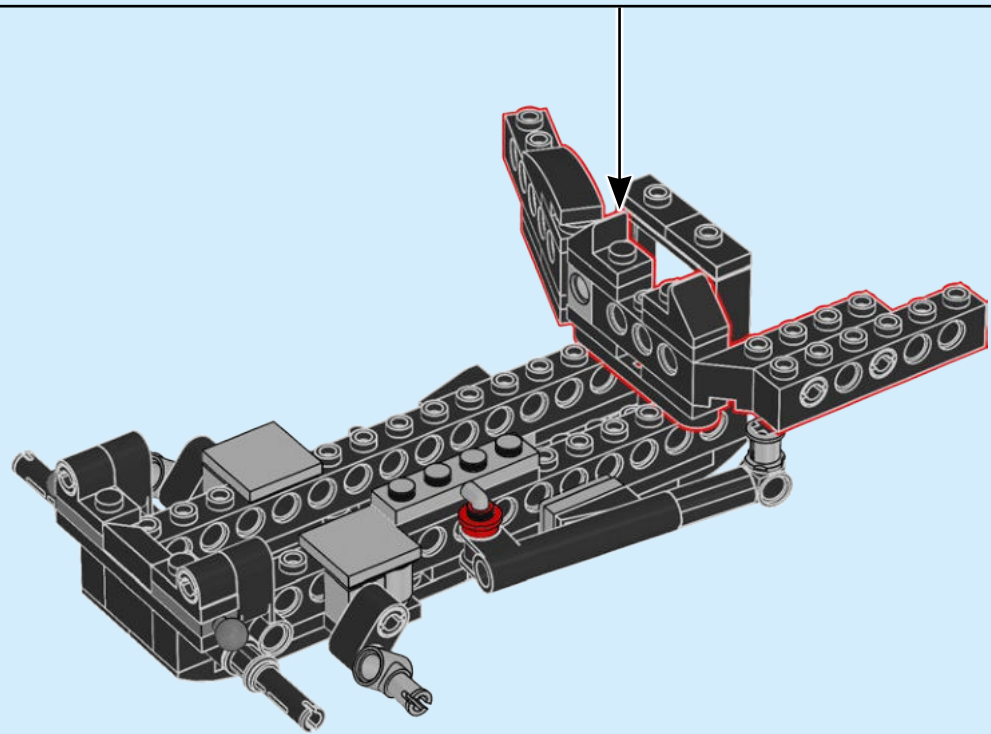
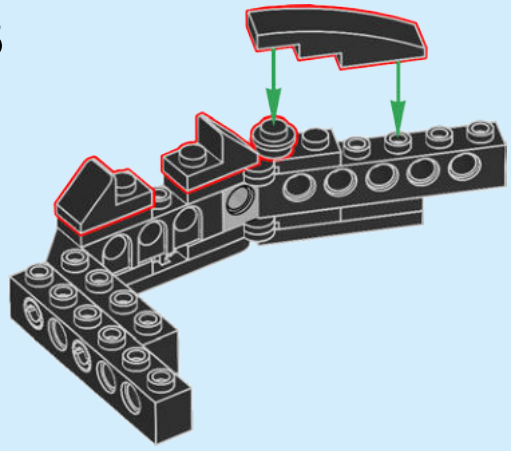

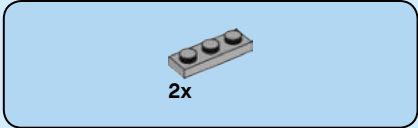
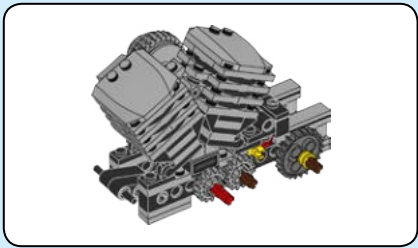

17

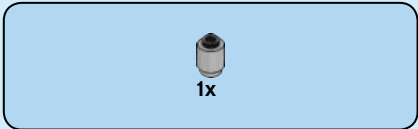
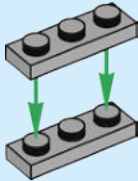

18

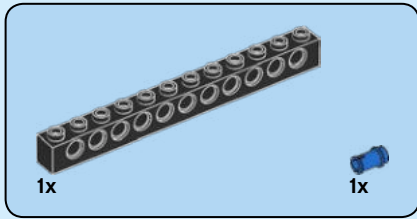
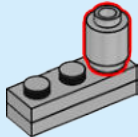

19

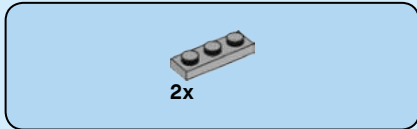
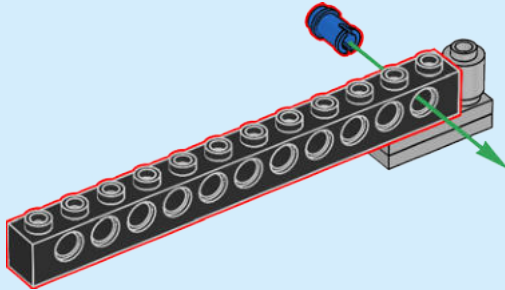

20

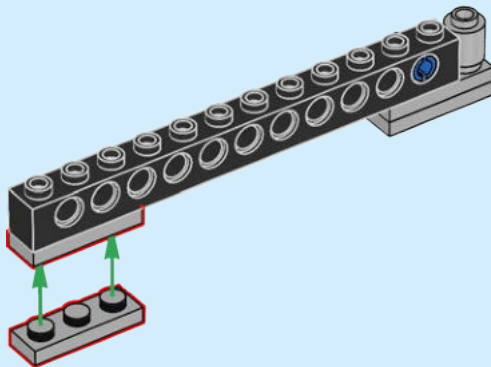

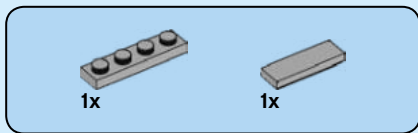

21

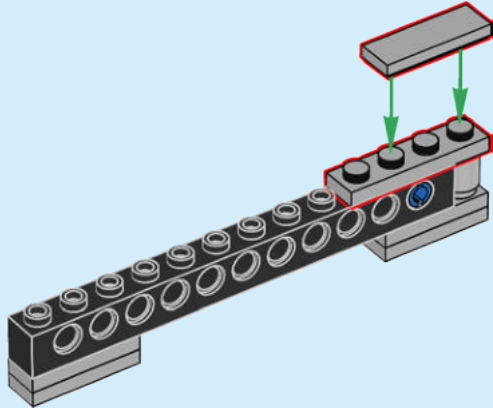

22

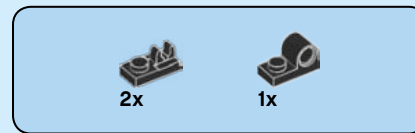
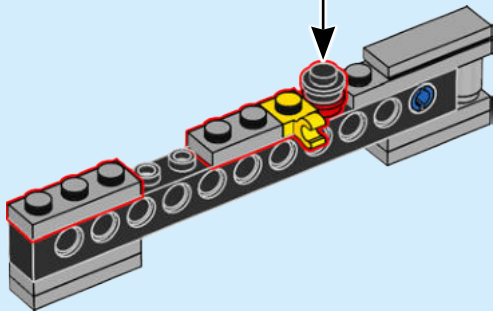
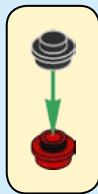

23

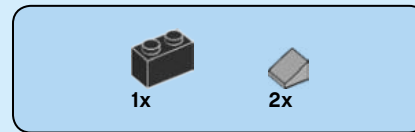
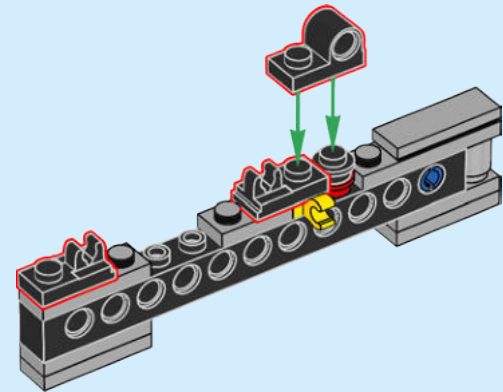

24

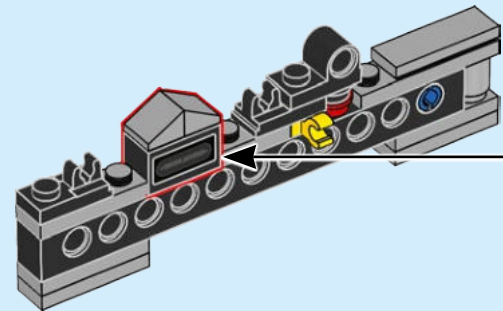
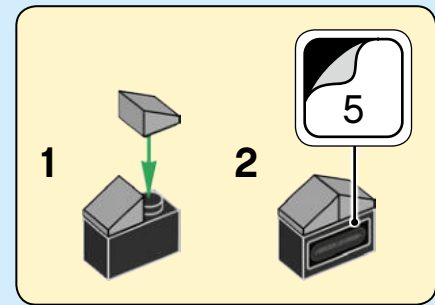



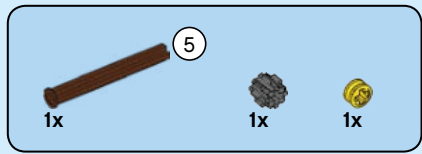

25

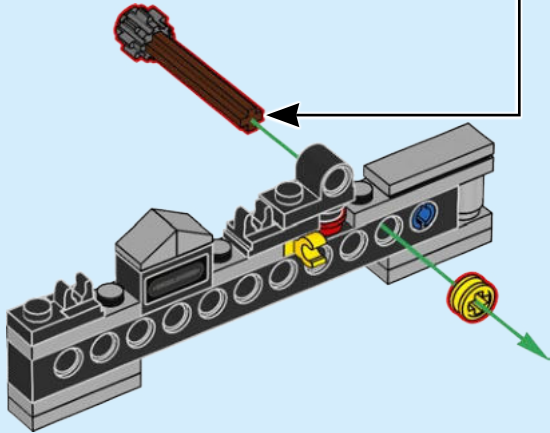
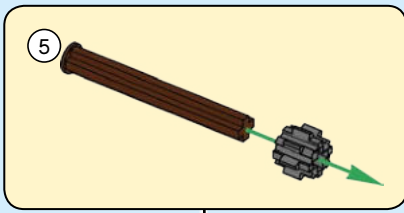

26

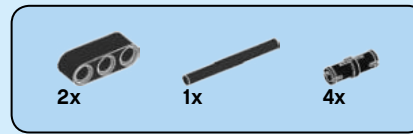
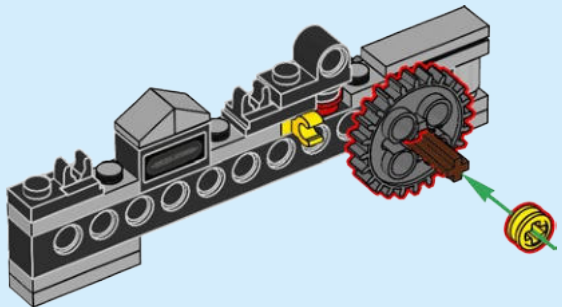

27

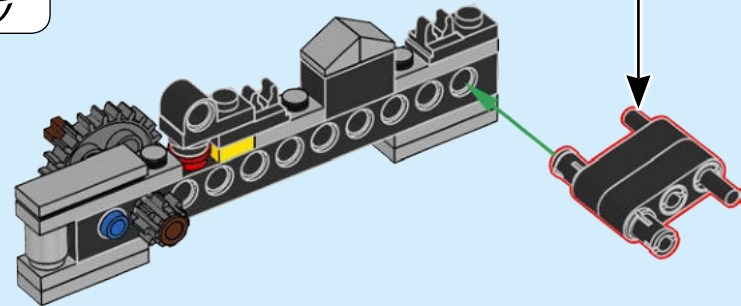
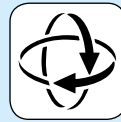
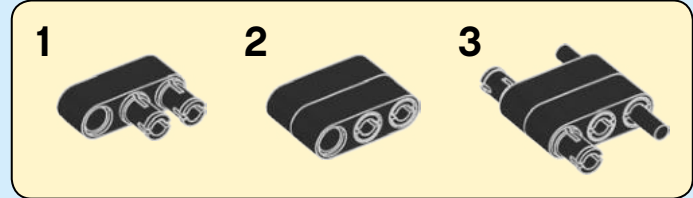

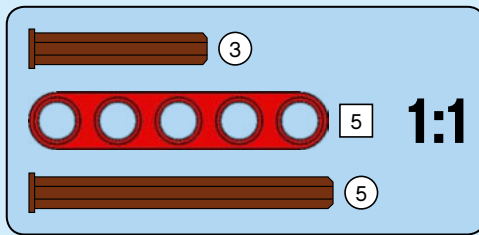
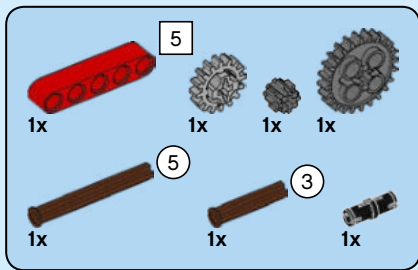

28

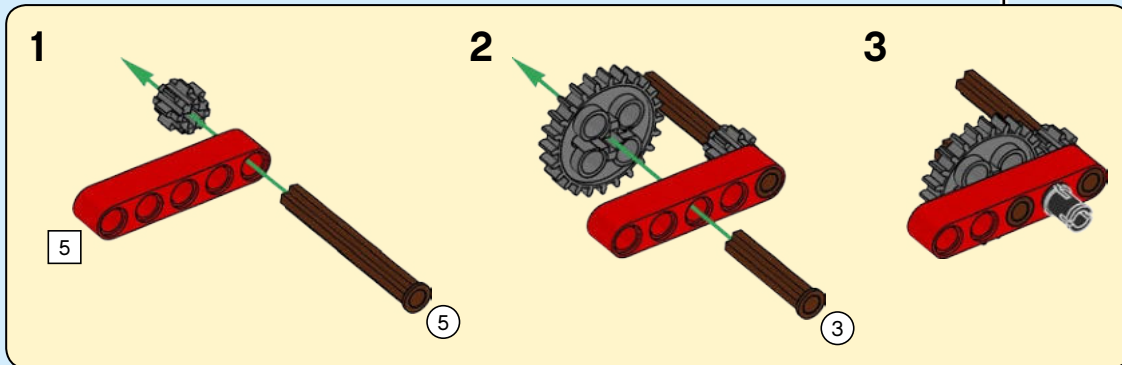
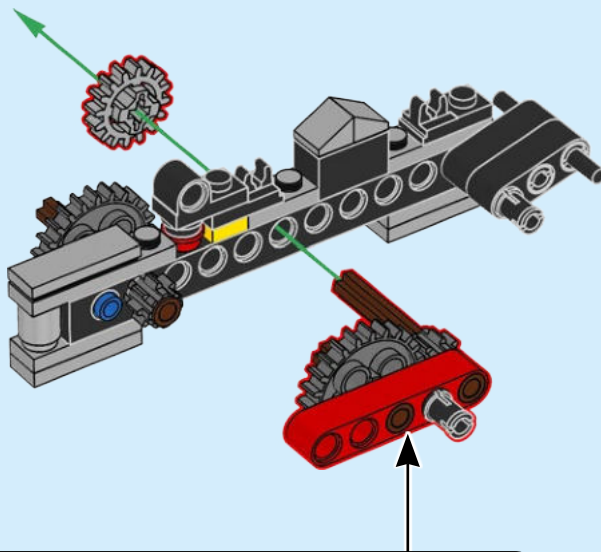

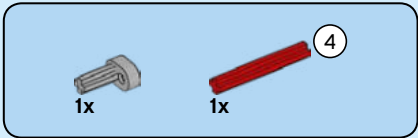
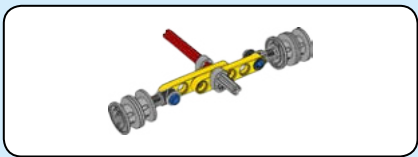

29

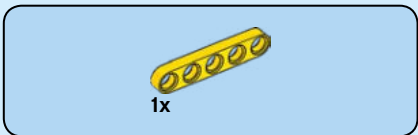
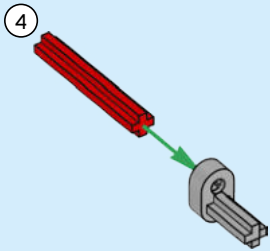

30

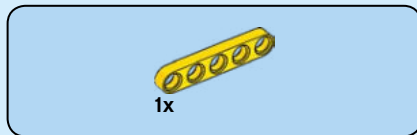
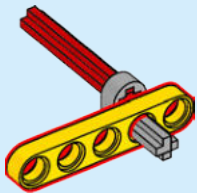

31

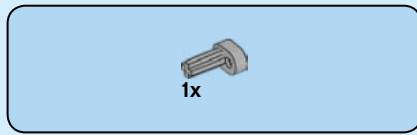
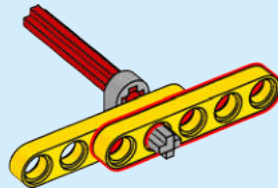

32

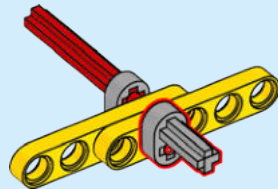



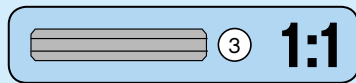

33

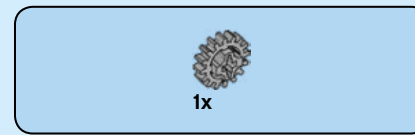
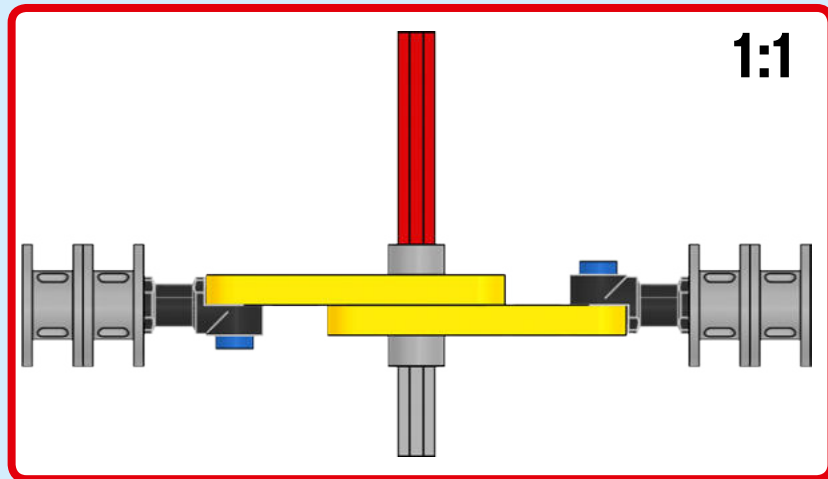
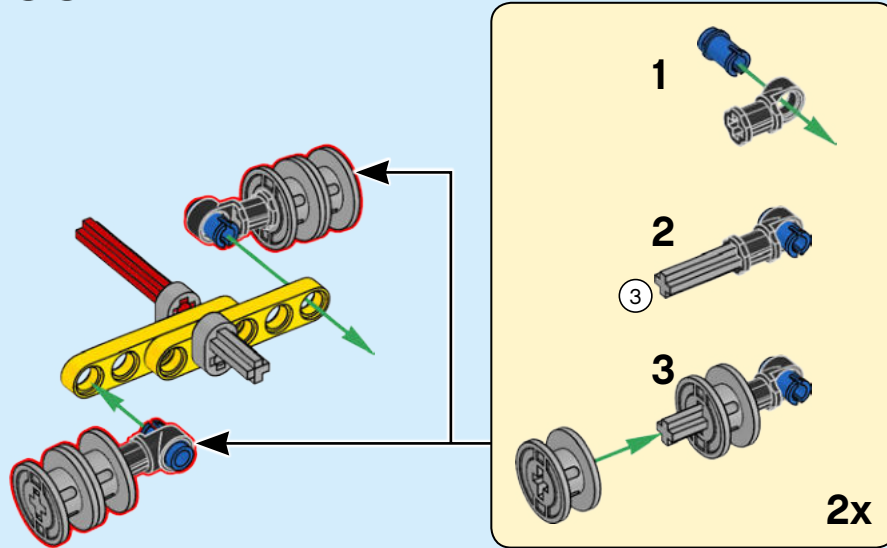

34

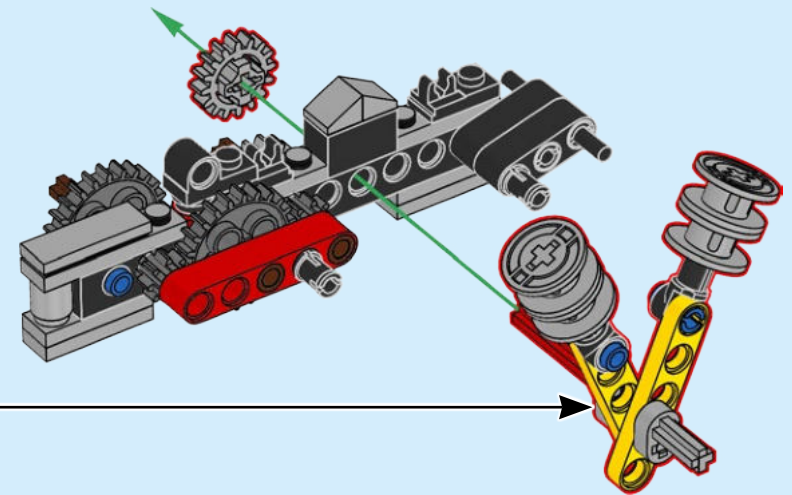

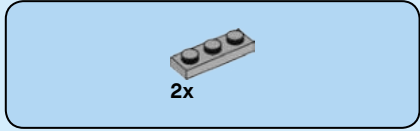
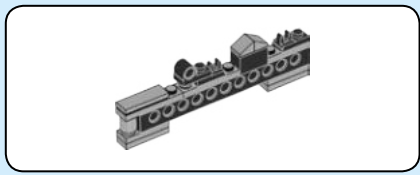

35

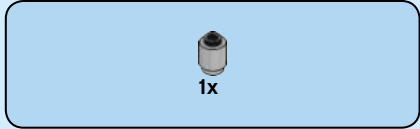
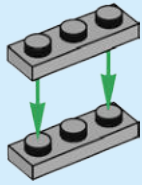

36

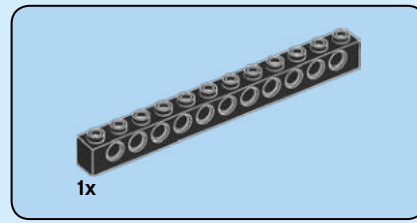
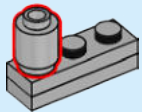

37

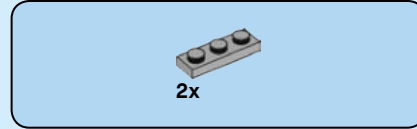
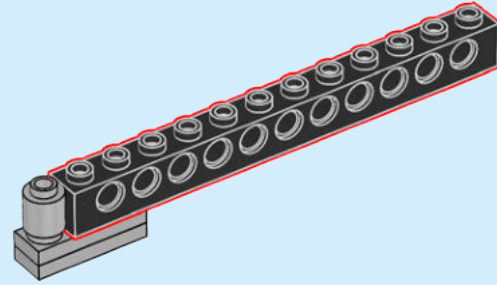

38

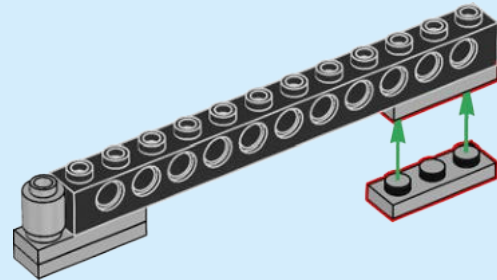

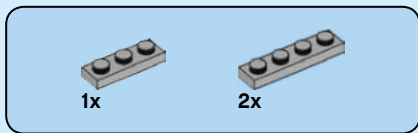

39

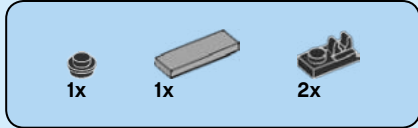
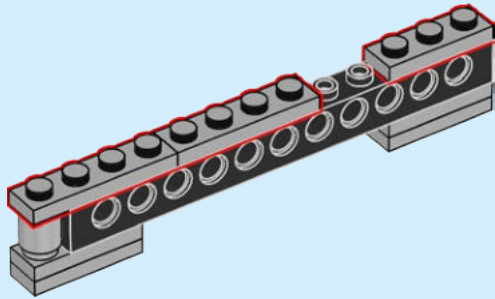

40

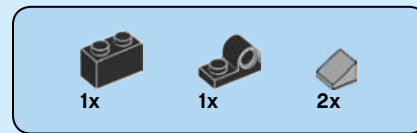
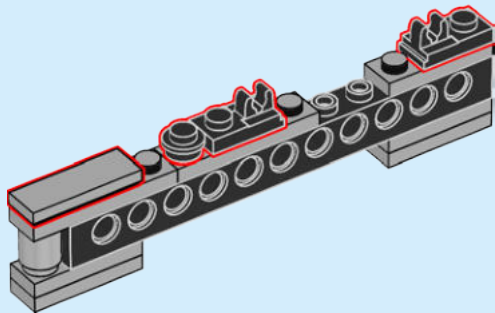

41

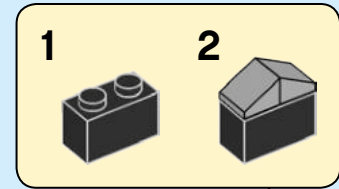
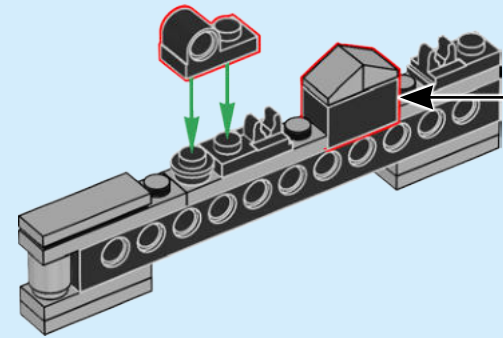

42

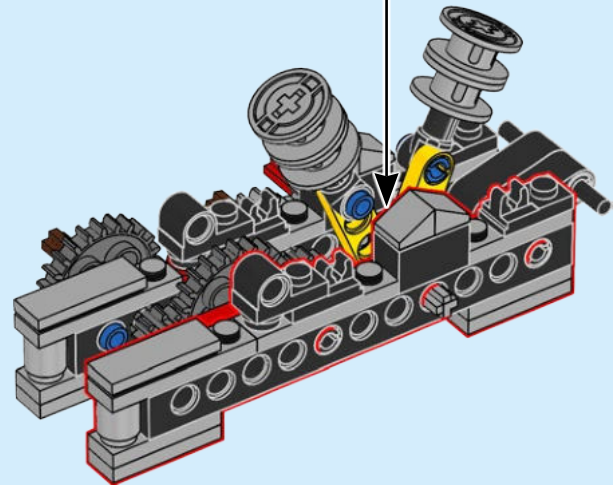



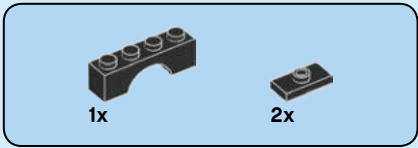

# 43

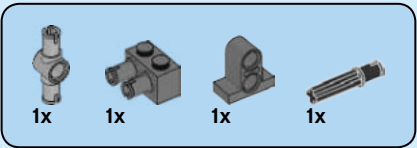
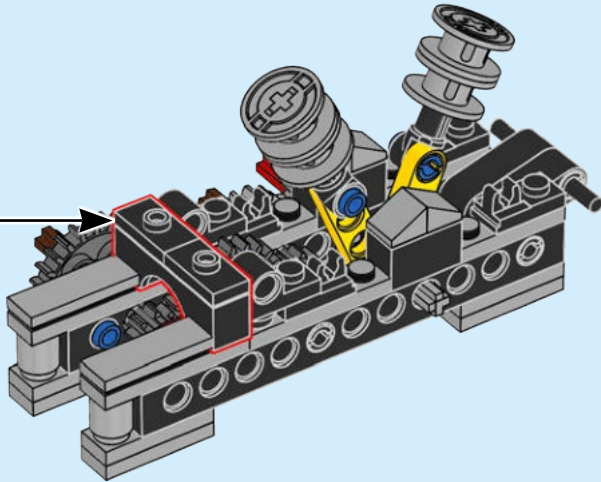
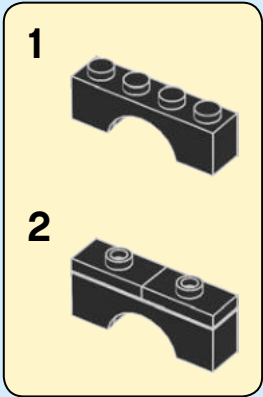

# 44

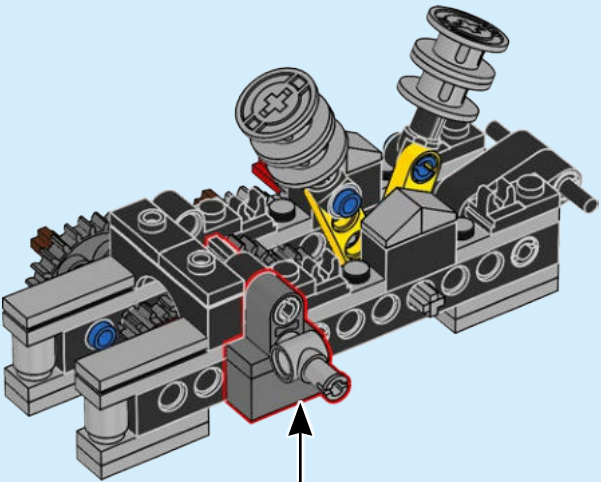
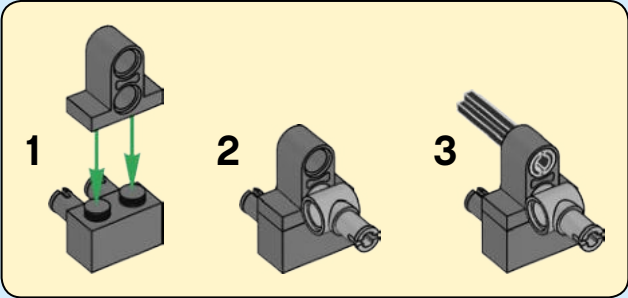

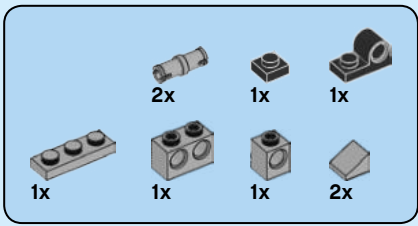

45

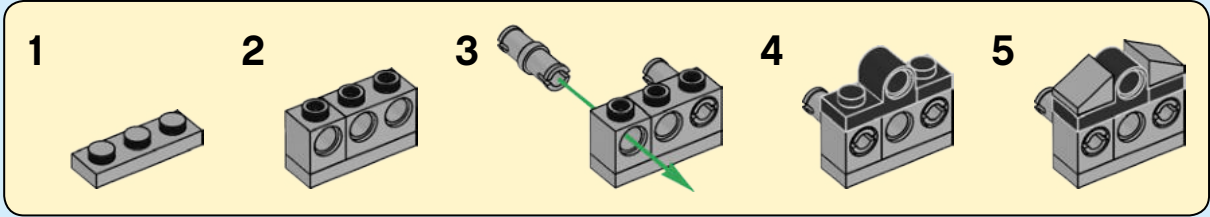
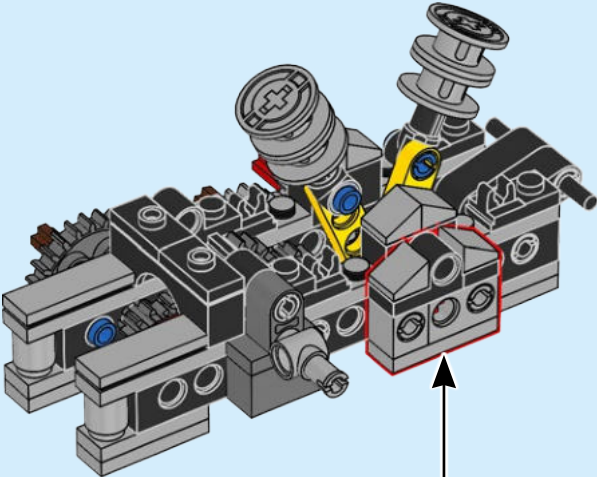

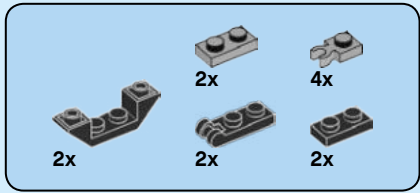

46

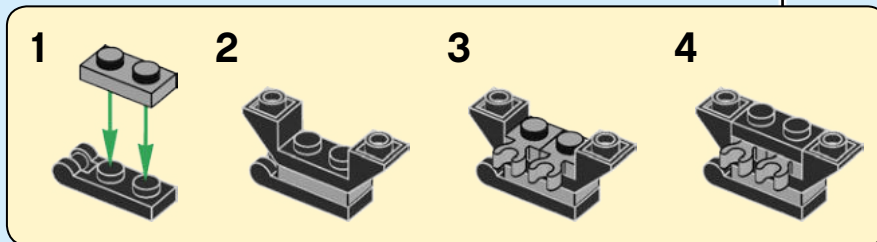
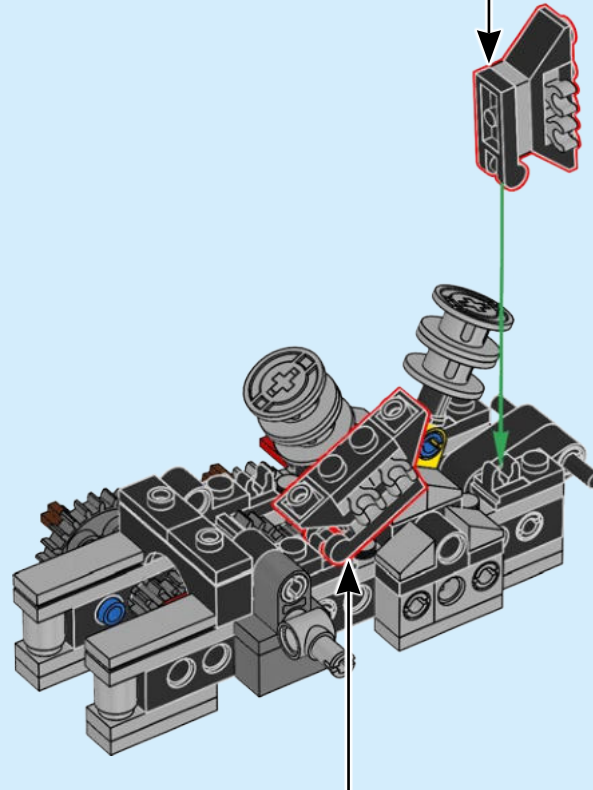
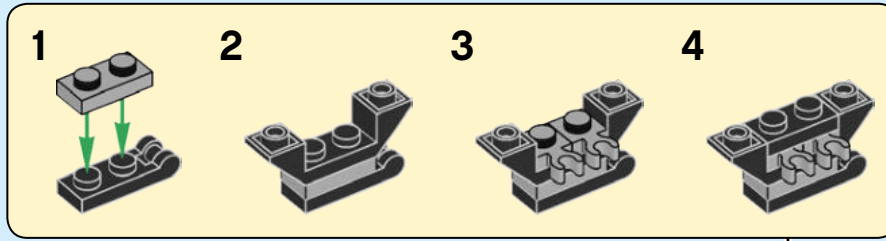



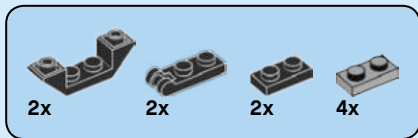

47

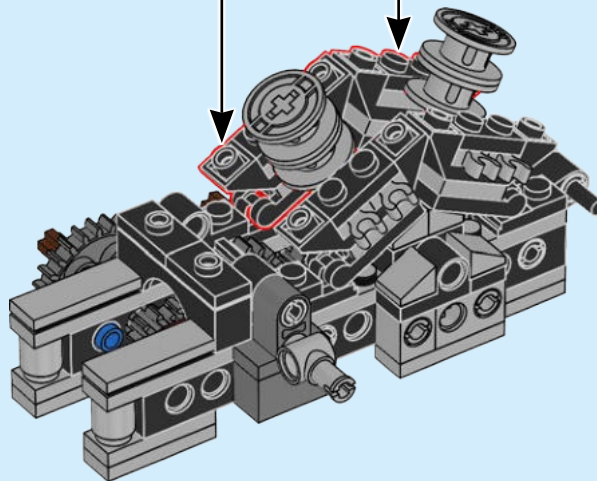
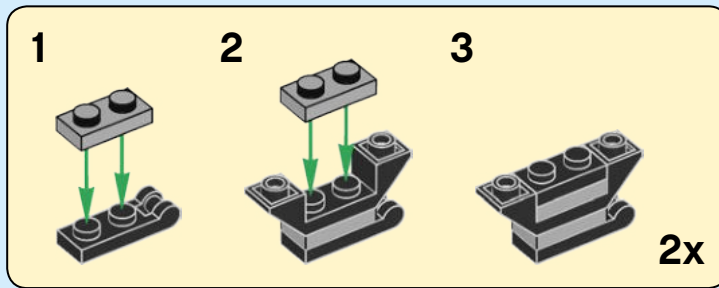

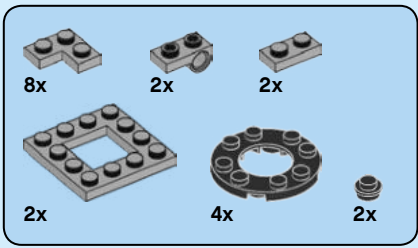

48

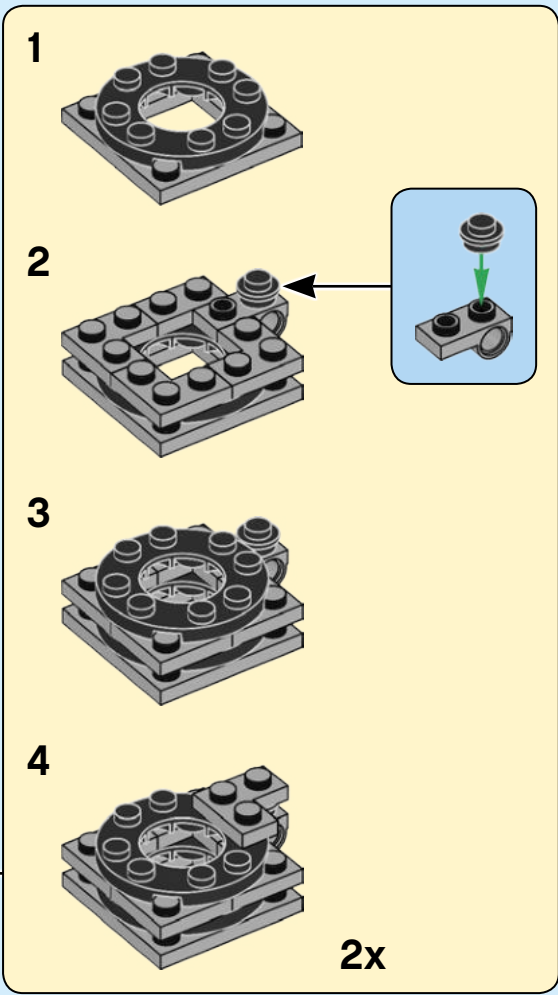
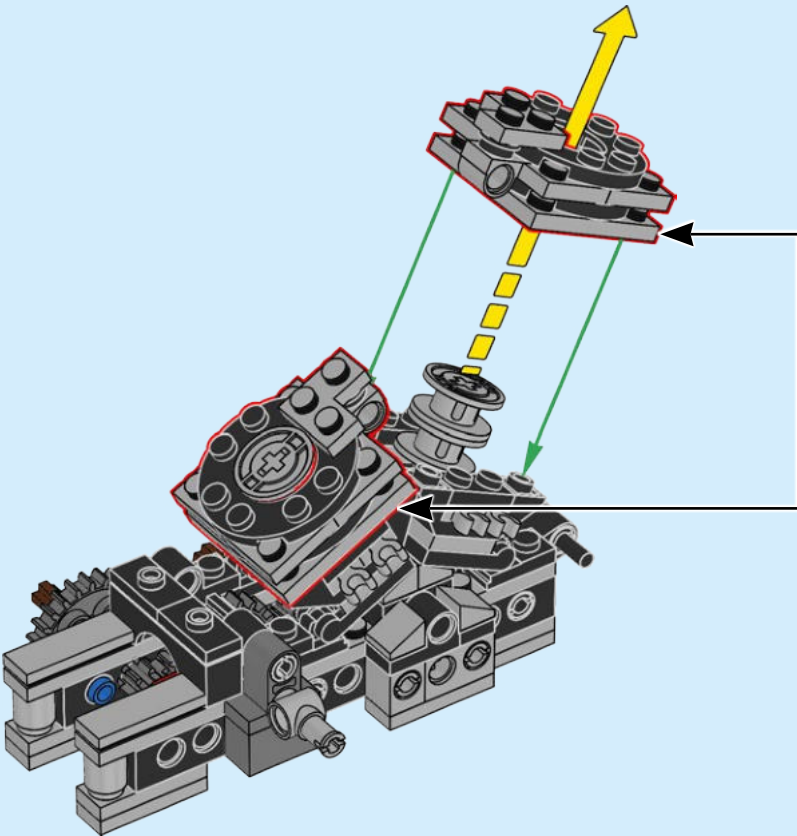



49

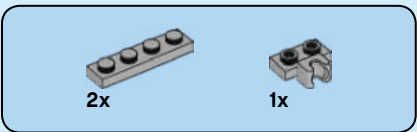
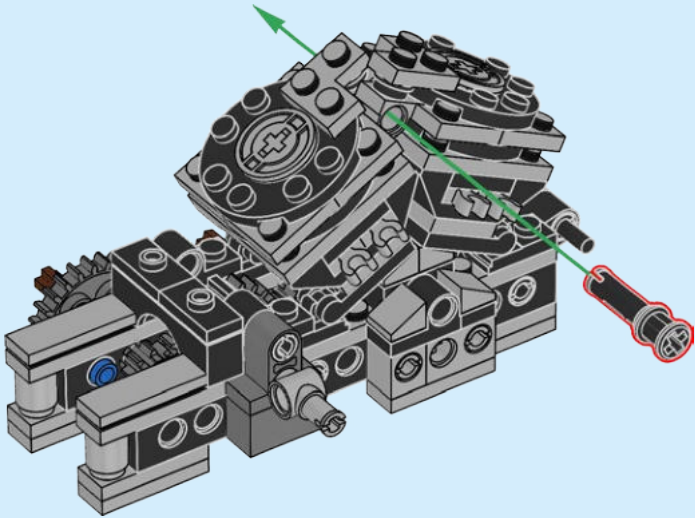

50

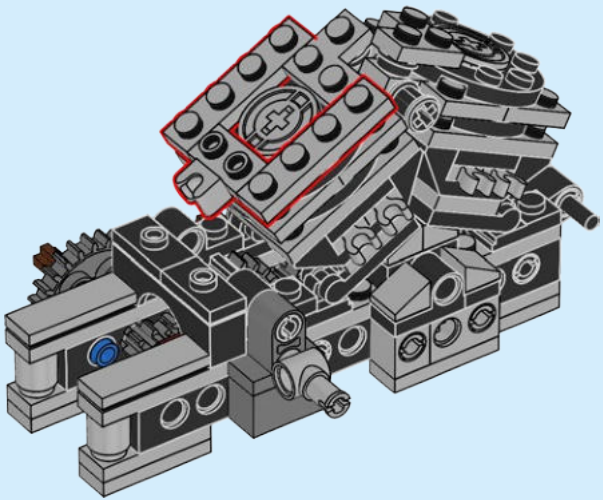

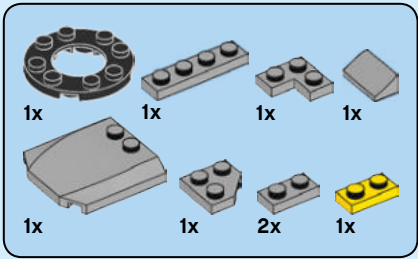

51

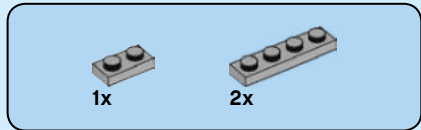
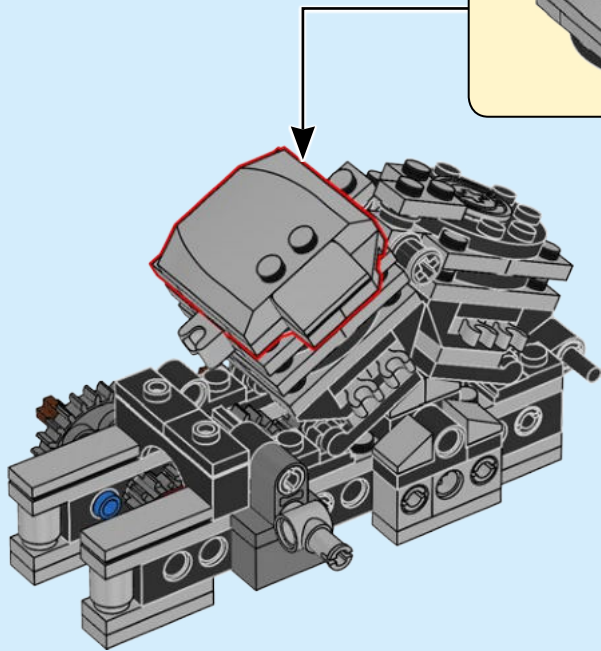
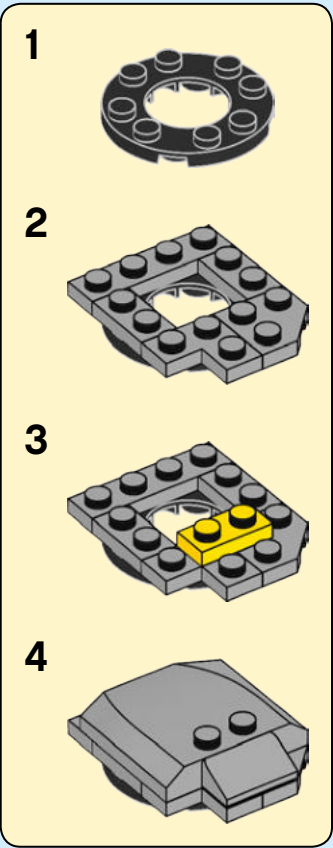

52

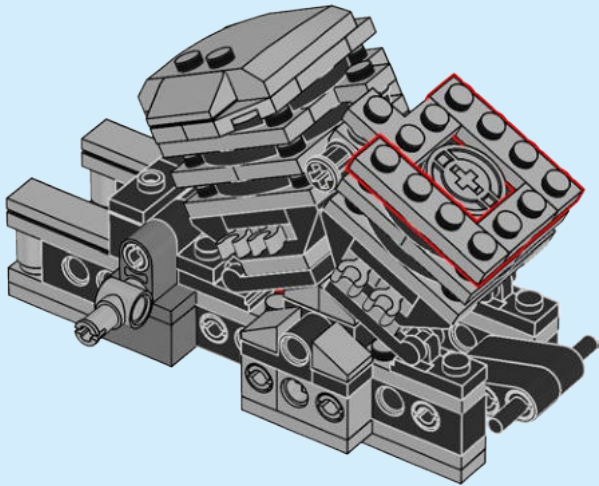



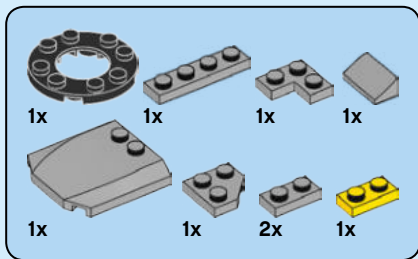

53

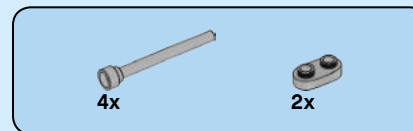
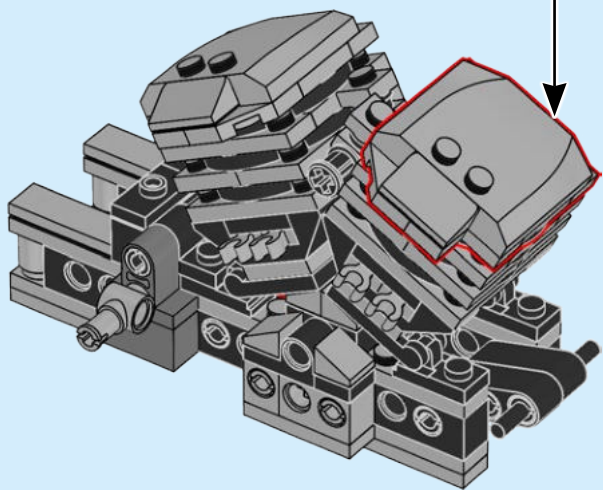
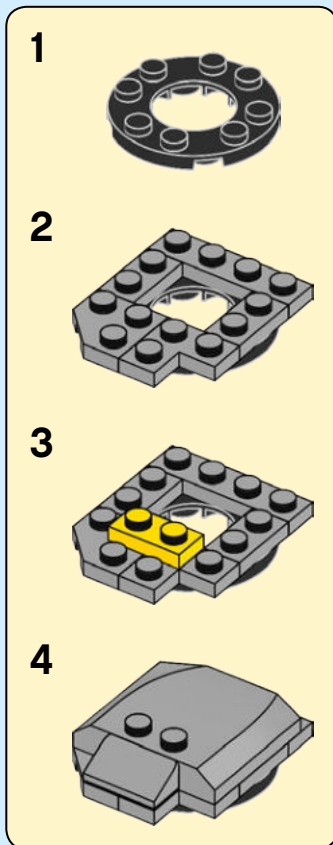

54

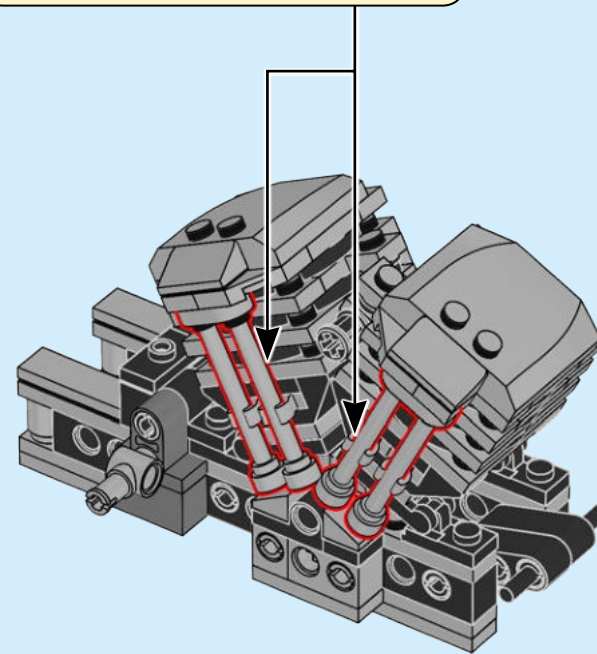
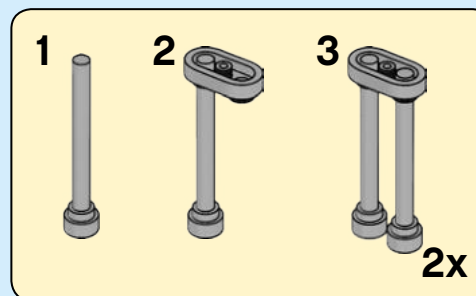

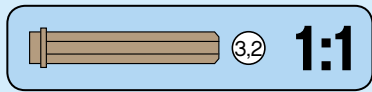
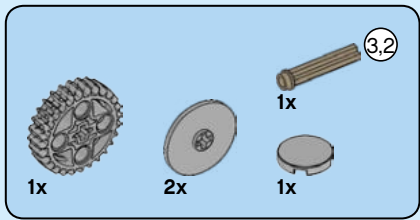

55

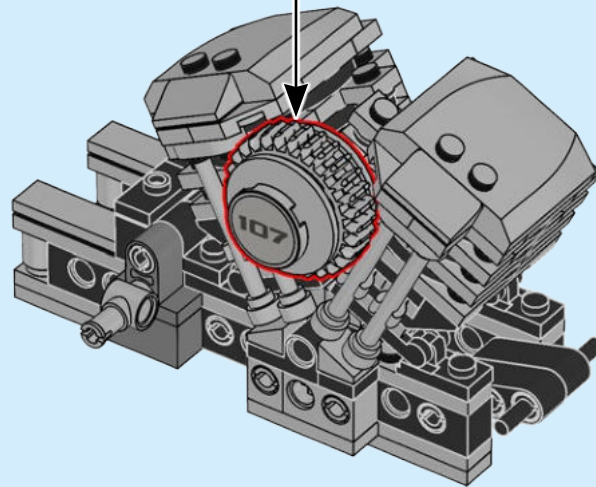
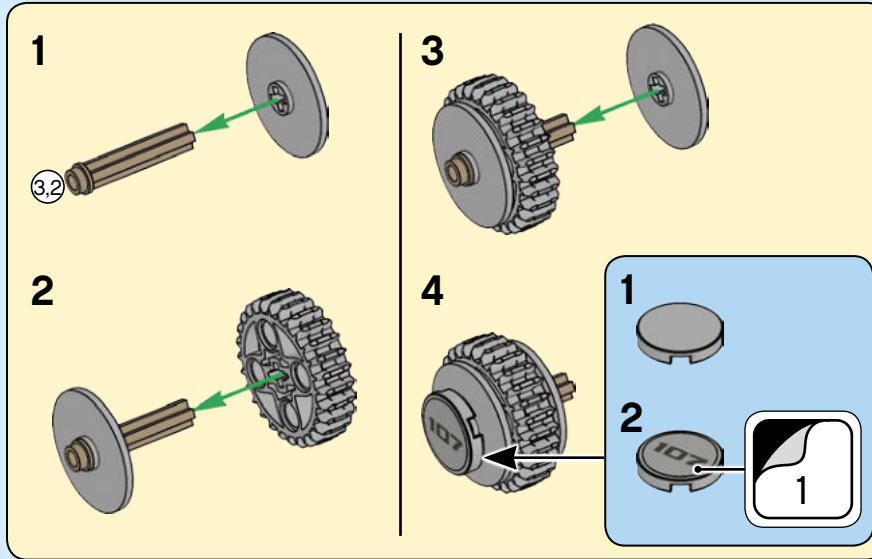

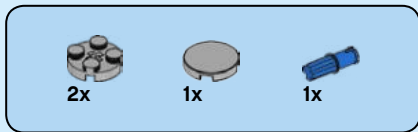

# 56

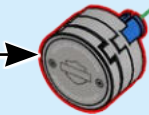
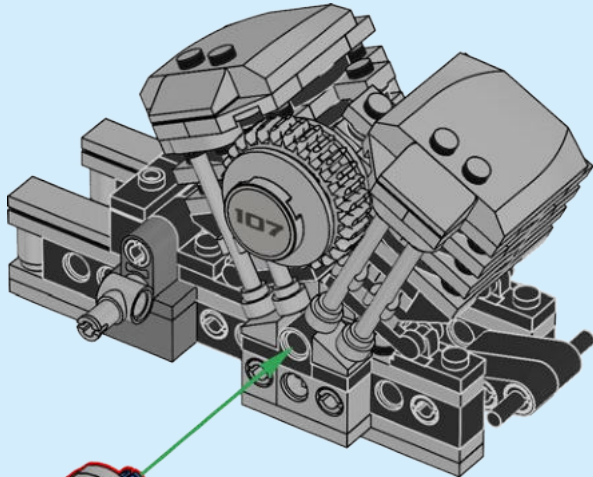
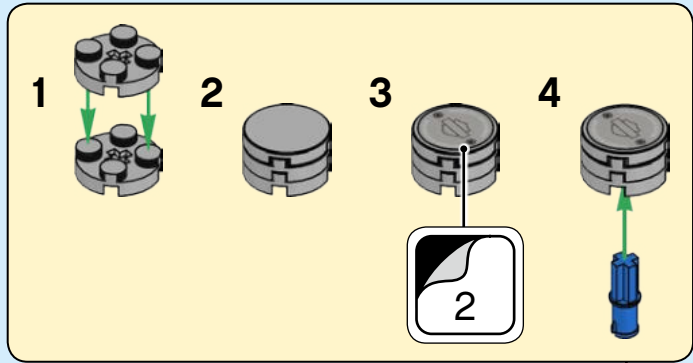



1x

57

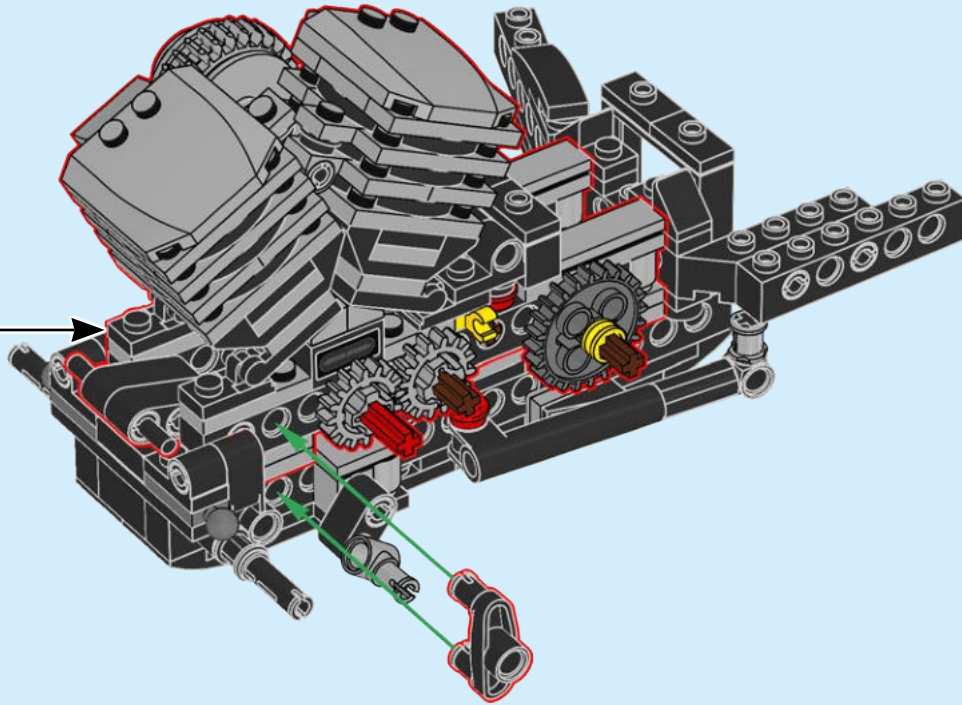



# THE PERFECT PISTON

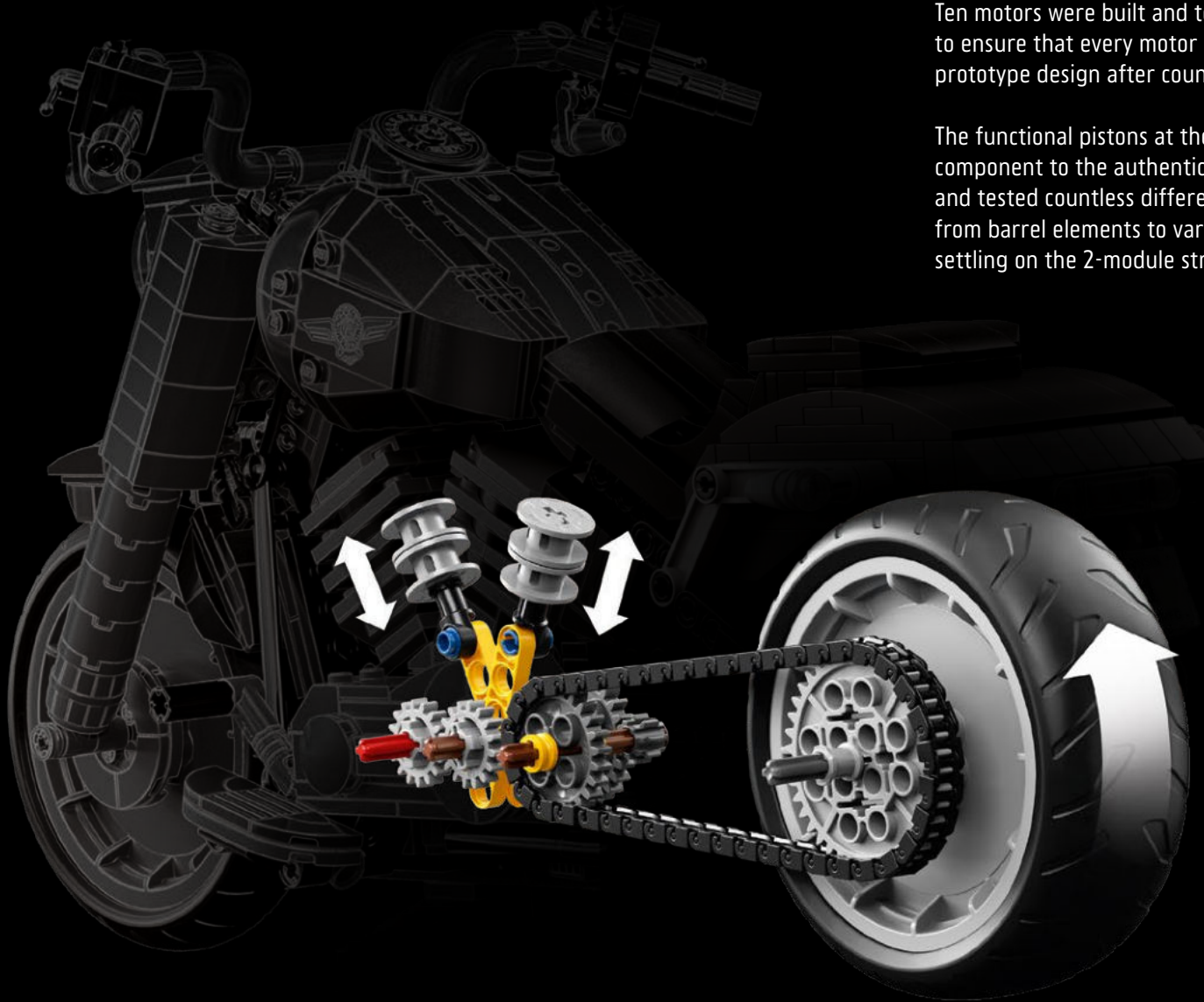

## RUNNING SMOOTH

Ten motors were built and tested, each for thousands of cycles, to ensure that every motor built would run as smoothly as the prototype design after countless hours of play.

The functional pistons at the core of the engine are a key component to the authenticity of this model. Mike explored and tested countless different designs for the piston head, from barrel elements to various minifigure helmets, before settling on the 2-module string spool used in the final design.

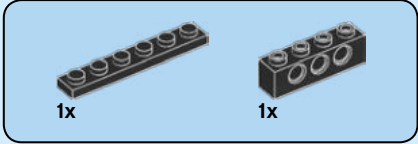
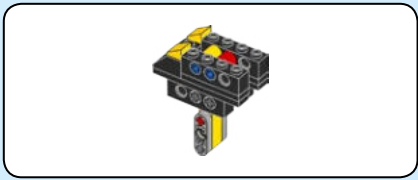

58

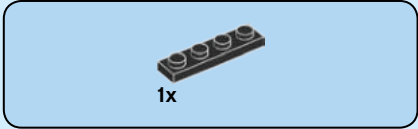
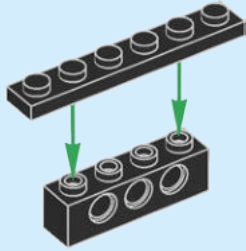

59

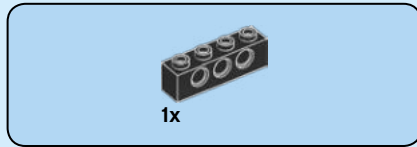
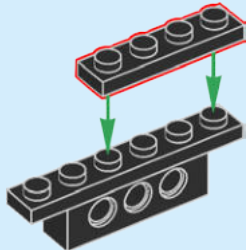

60

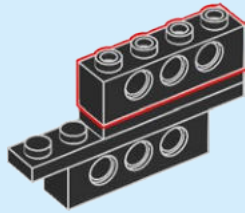

61

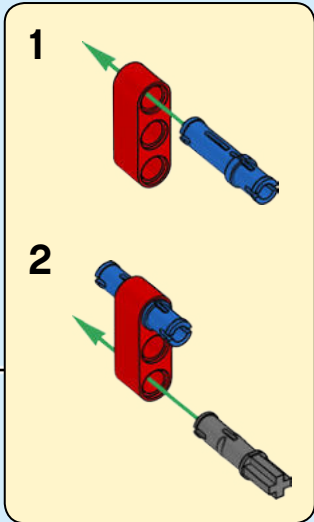
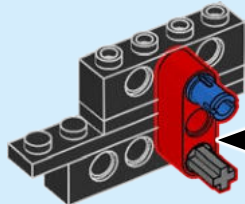

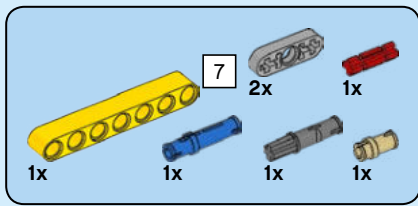

# 62

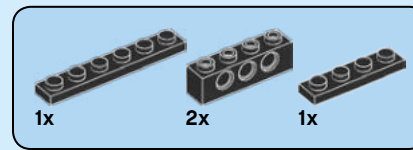
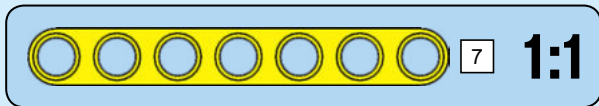
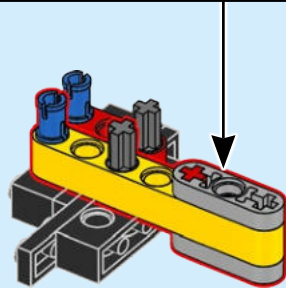
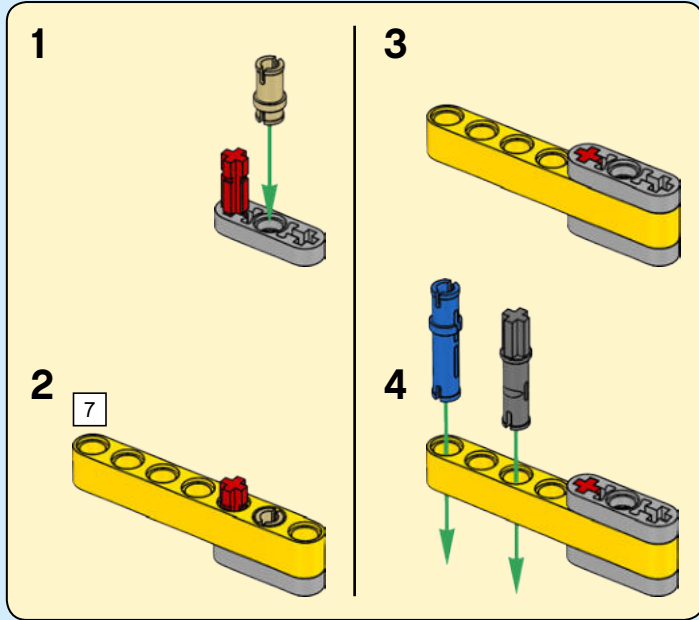

# 63

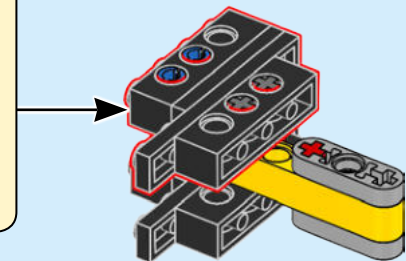
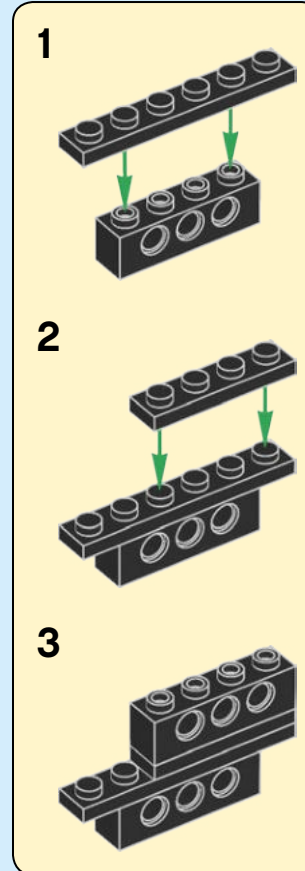

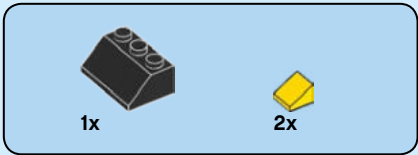

64

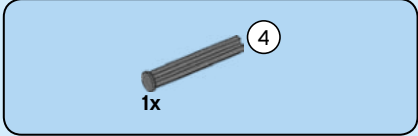
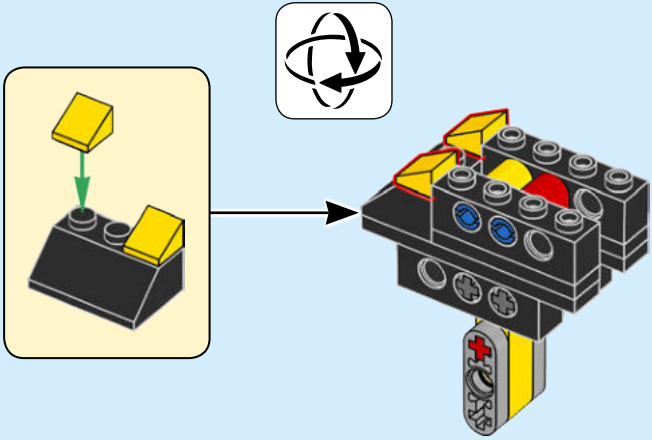

65

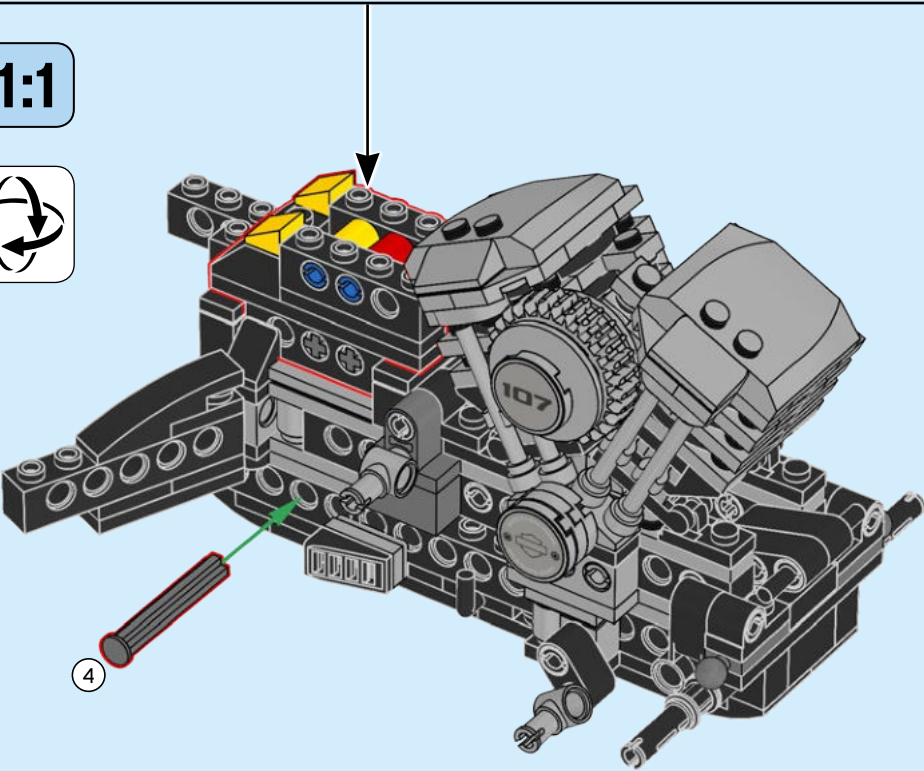



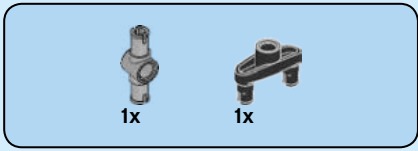

66

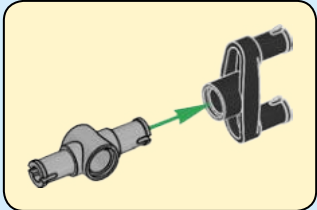
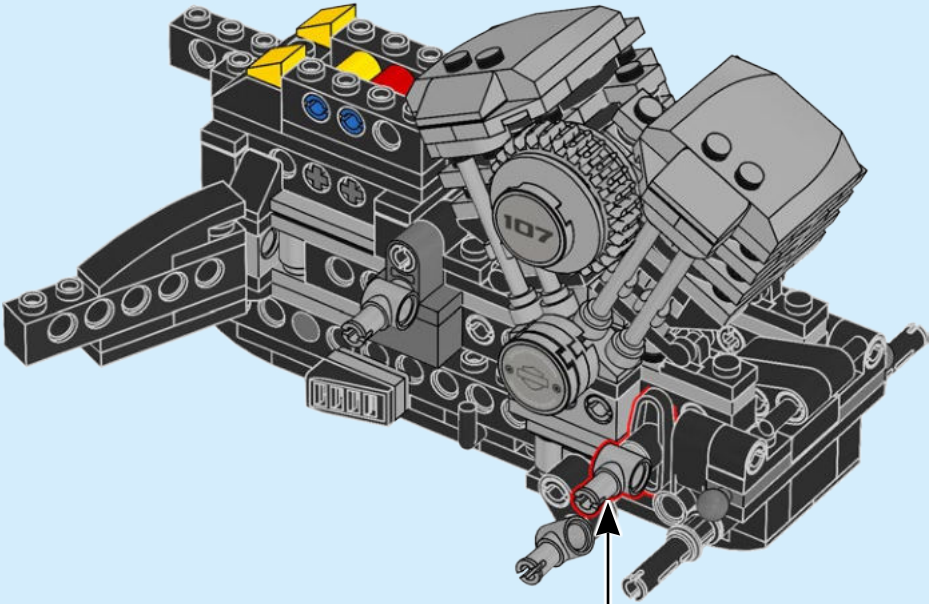

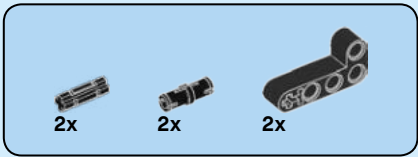
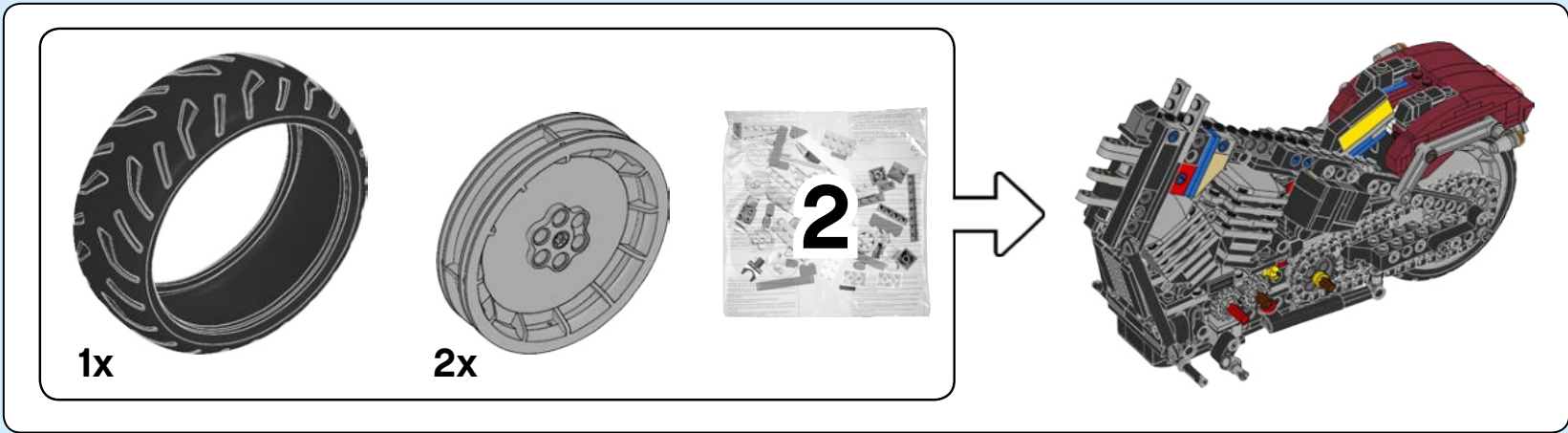

67

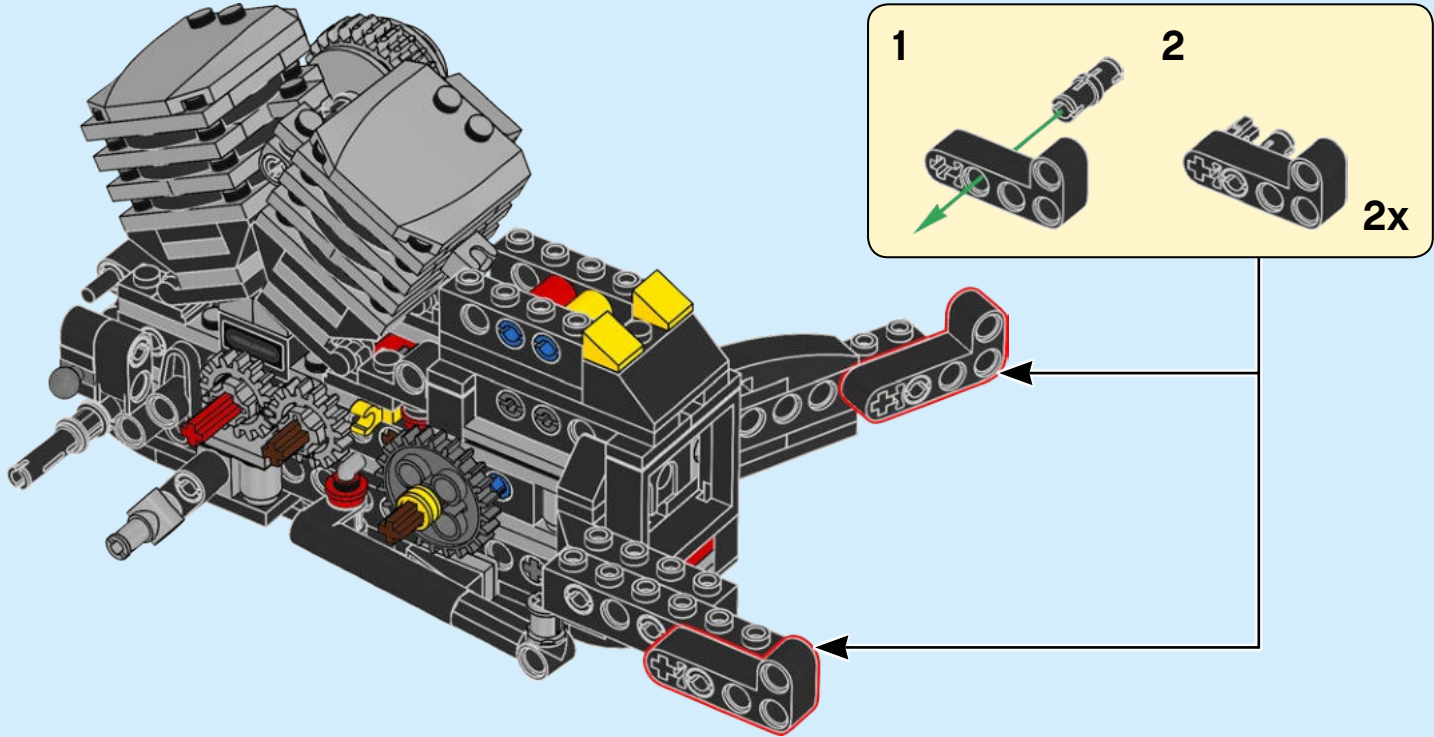

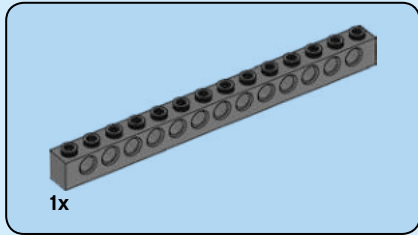
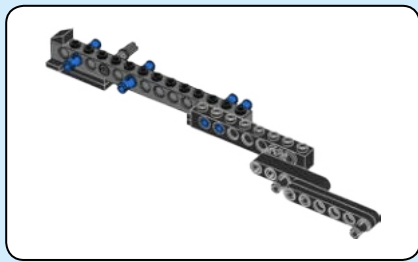

1x

68

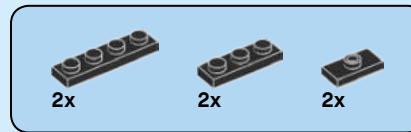
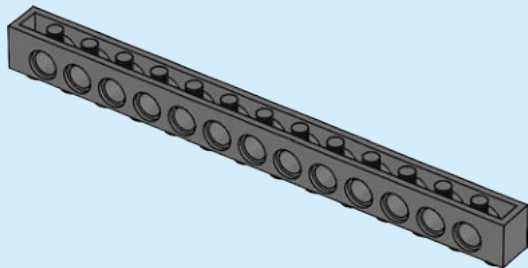

2x

2x

2x

69

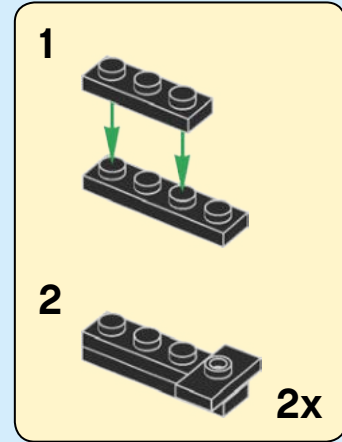

1

2

2x

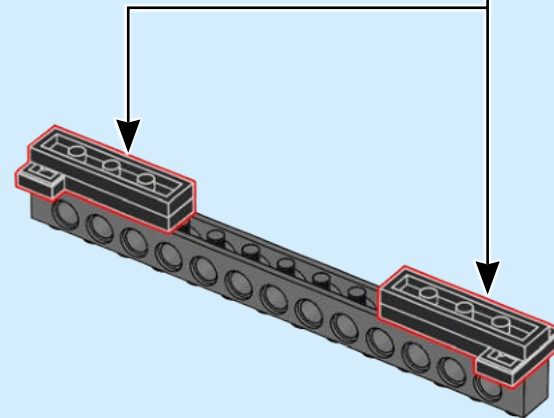



1x

# 70

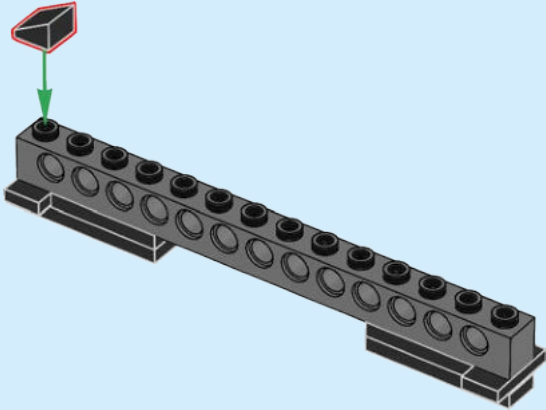

4x



1x

# 71

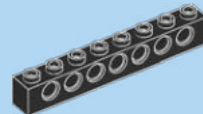
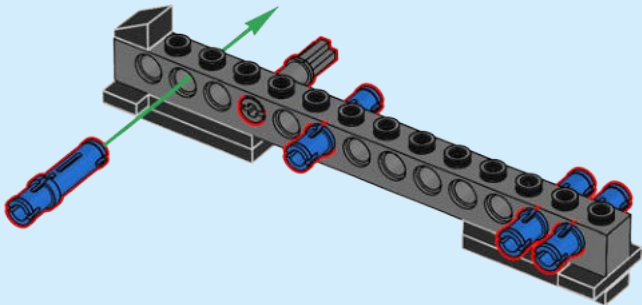

1x



1x

# 72

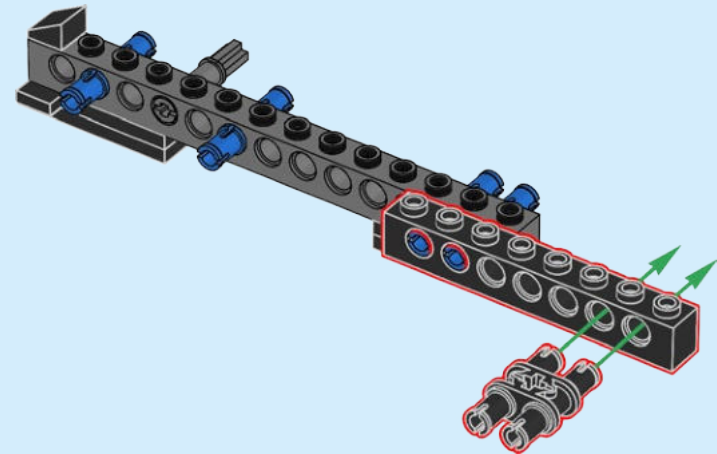



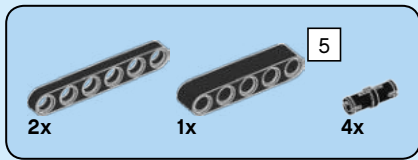

73

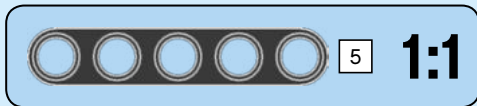
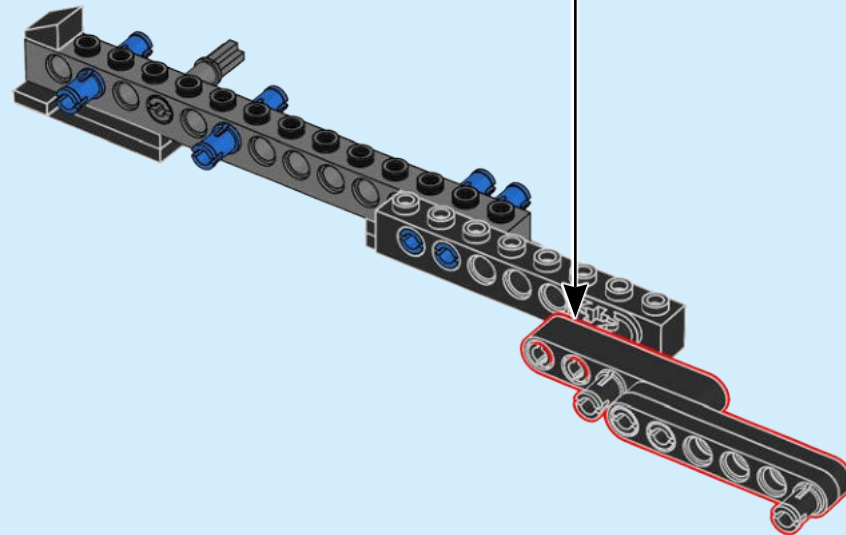
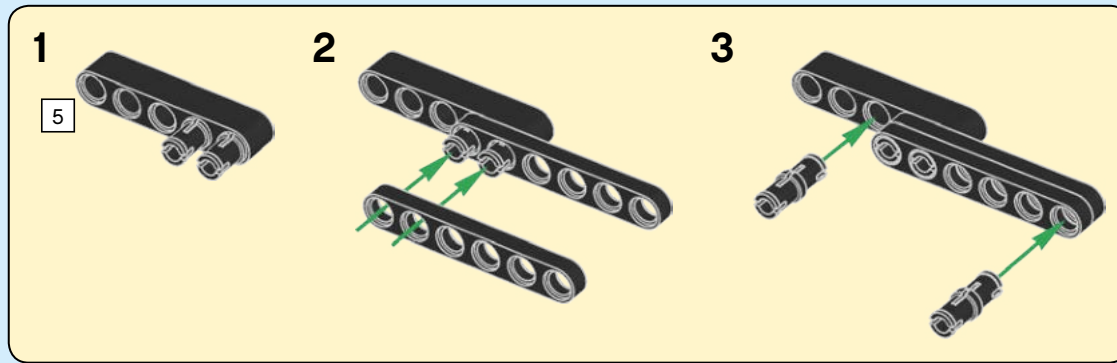

74

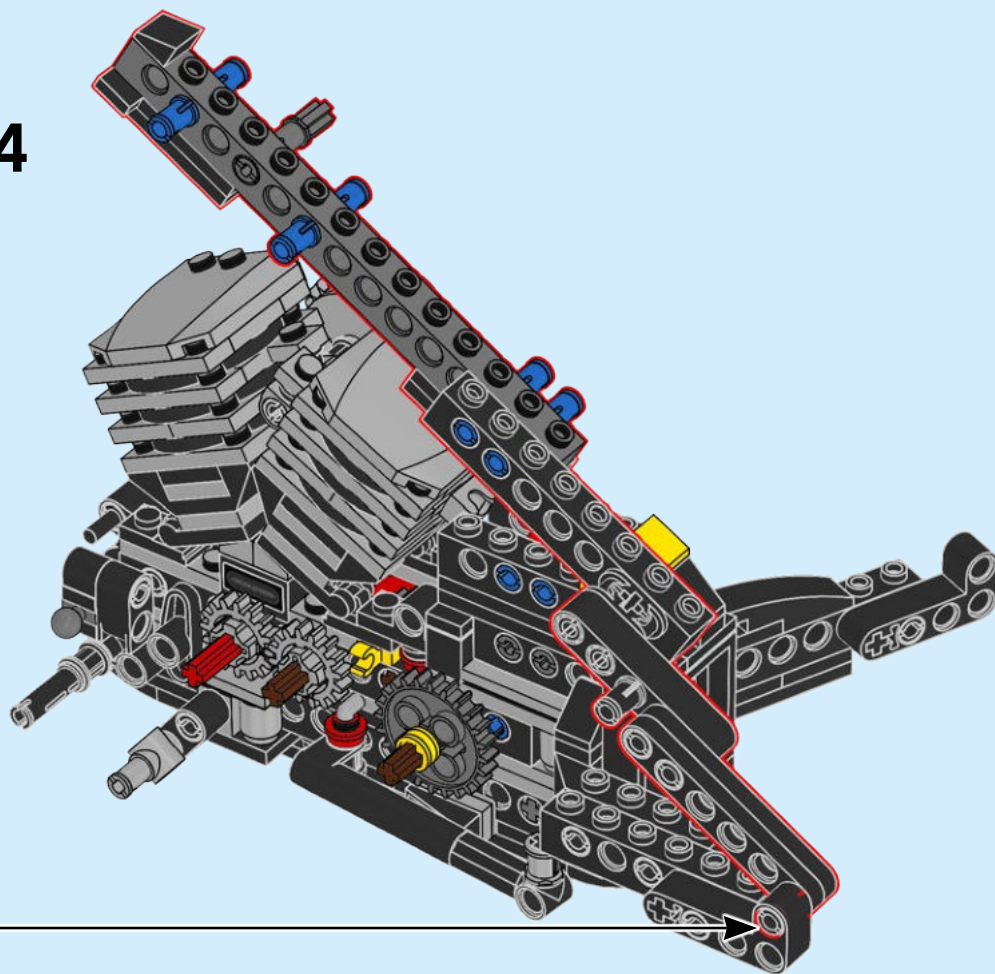

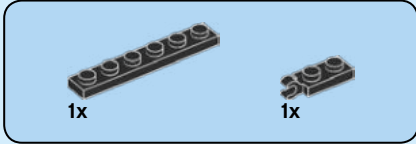
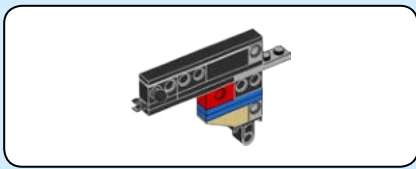

75

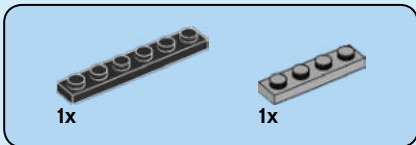
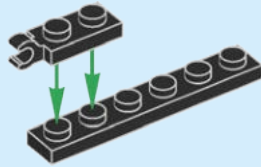

76

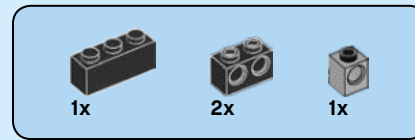
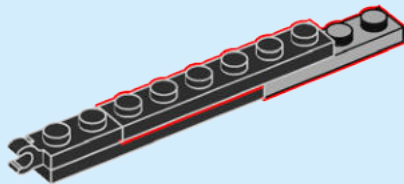

77

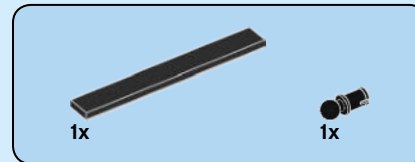
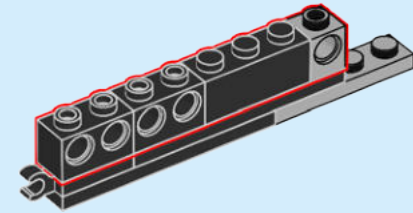

78

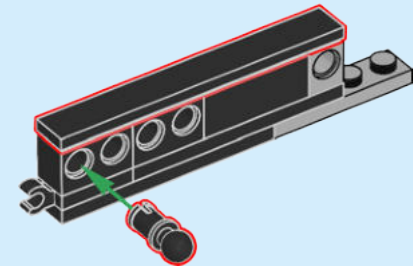

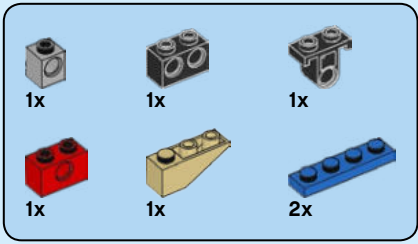

# 79

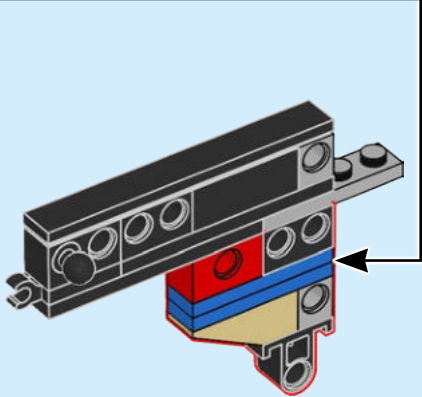
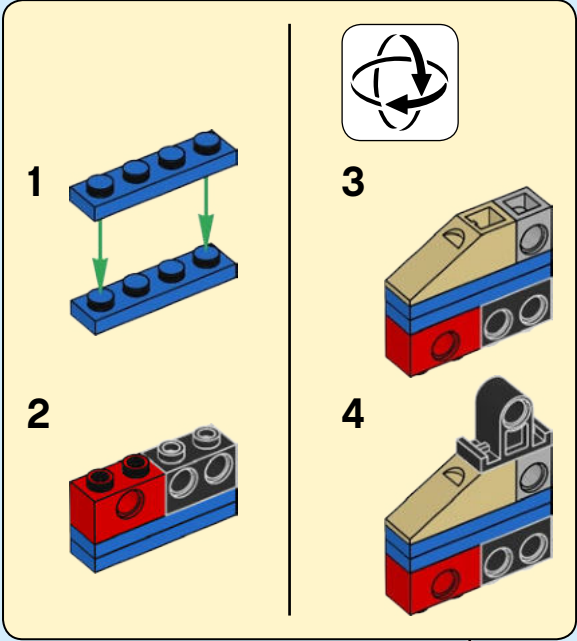

# 80

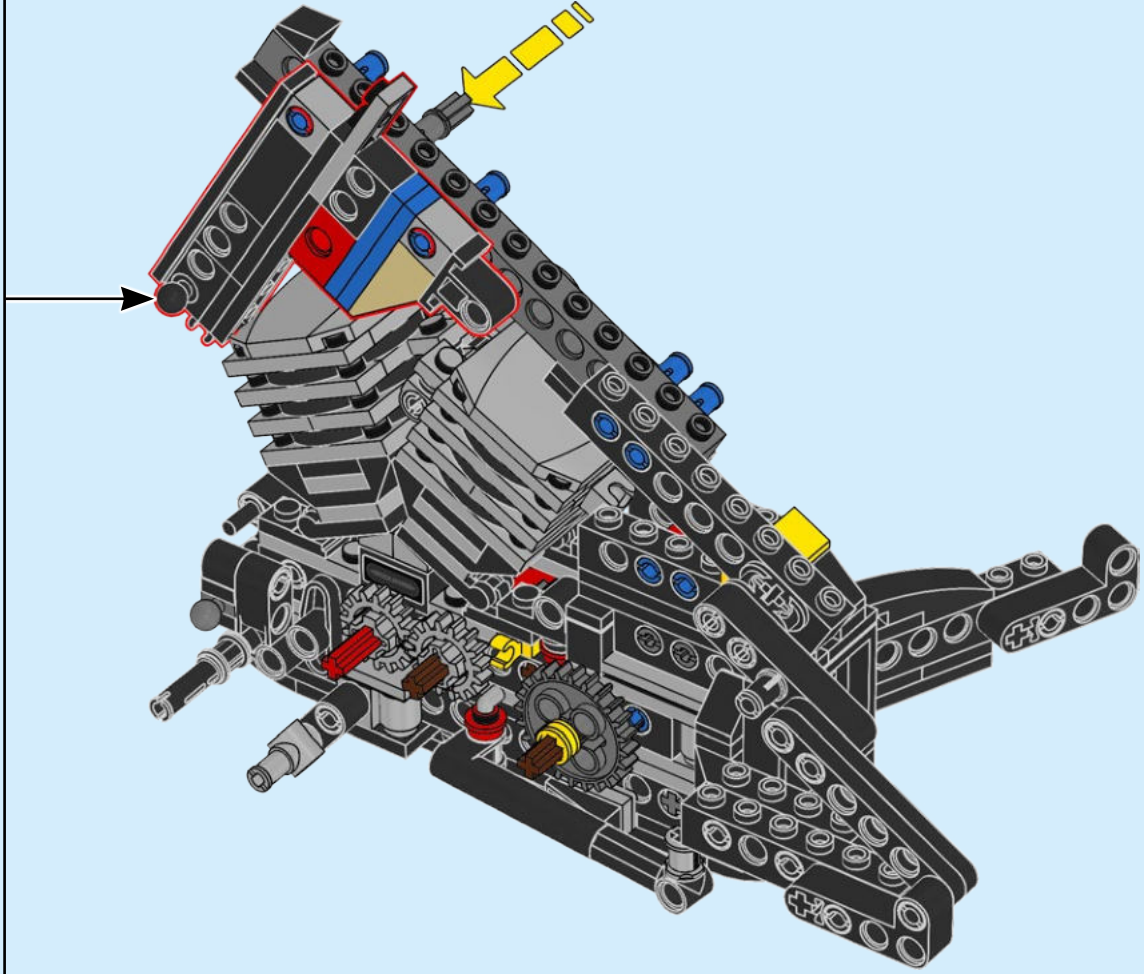



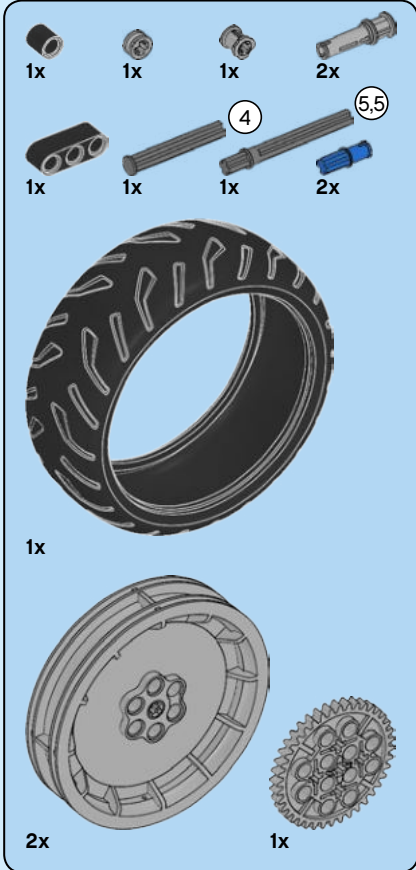

81

1

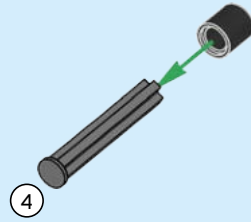

2

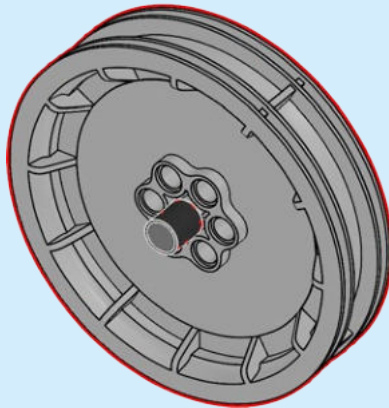

3

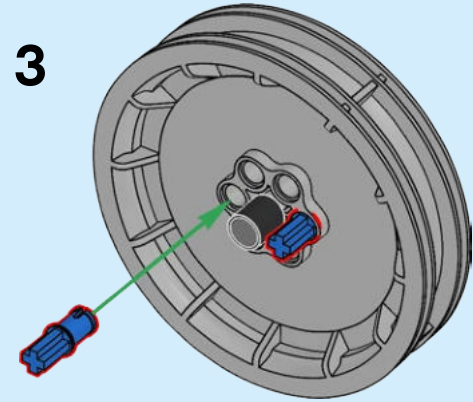

4

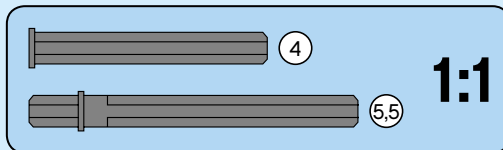
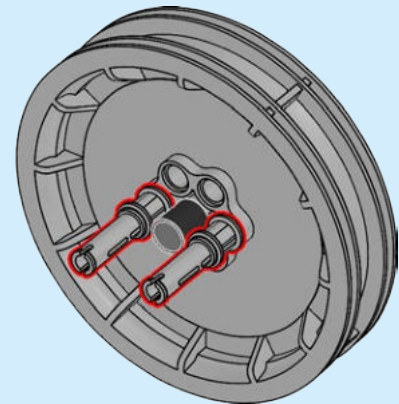

5

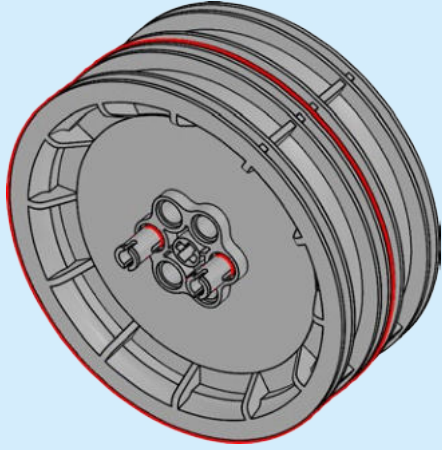

6

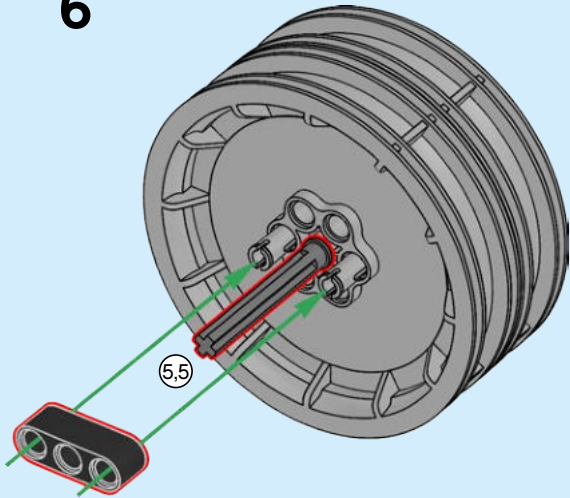

7

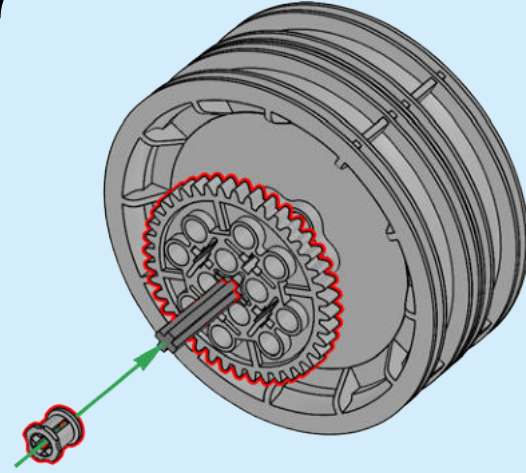

8



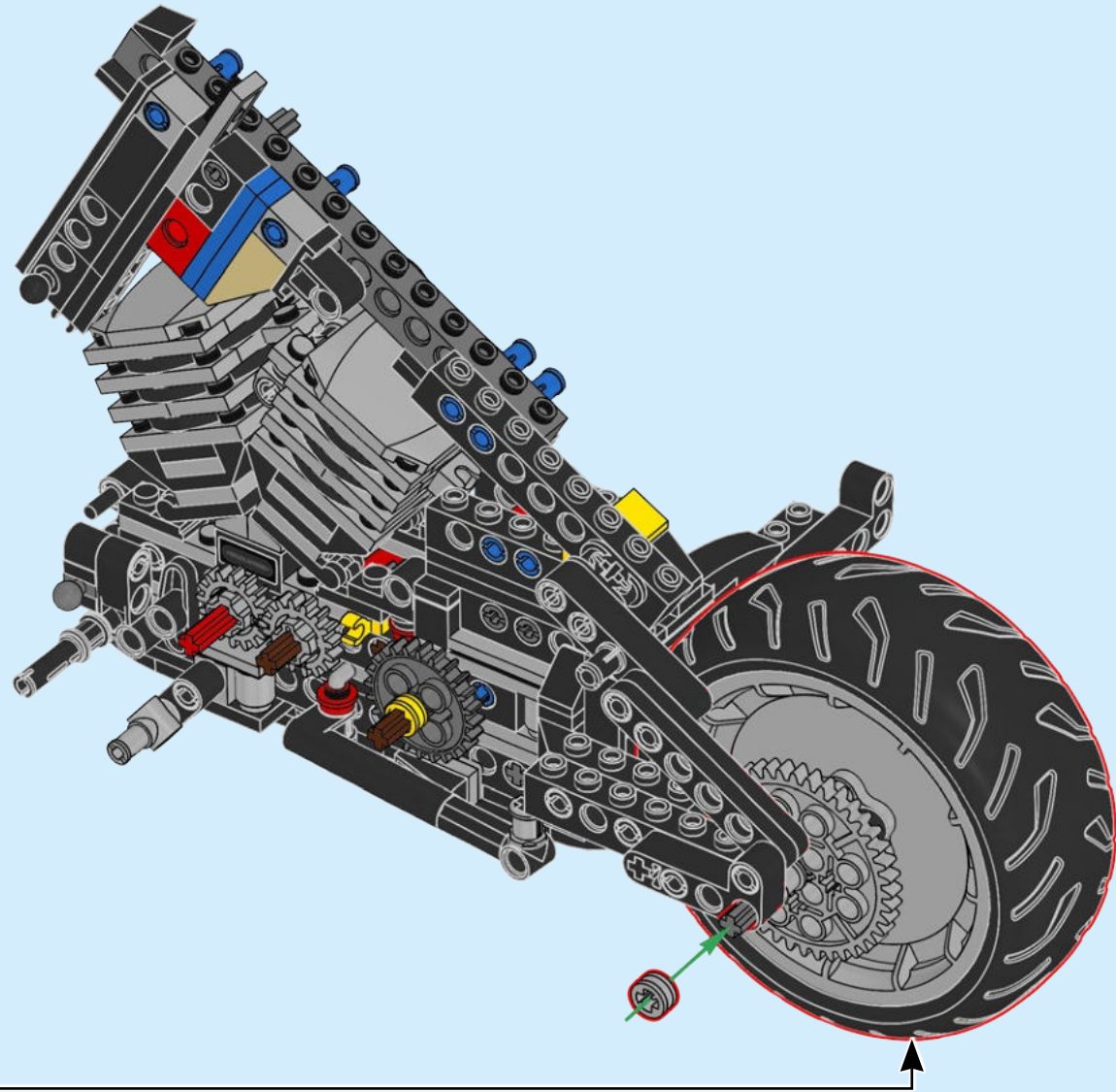



1x

82

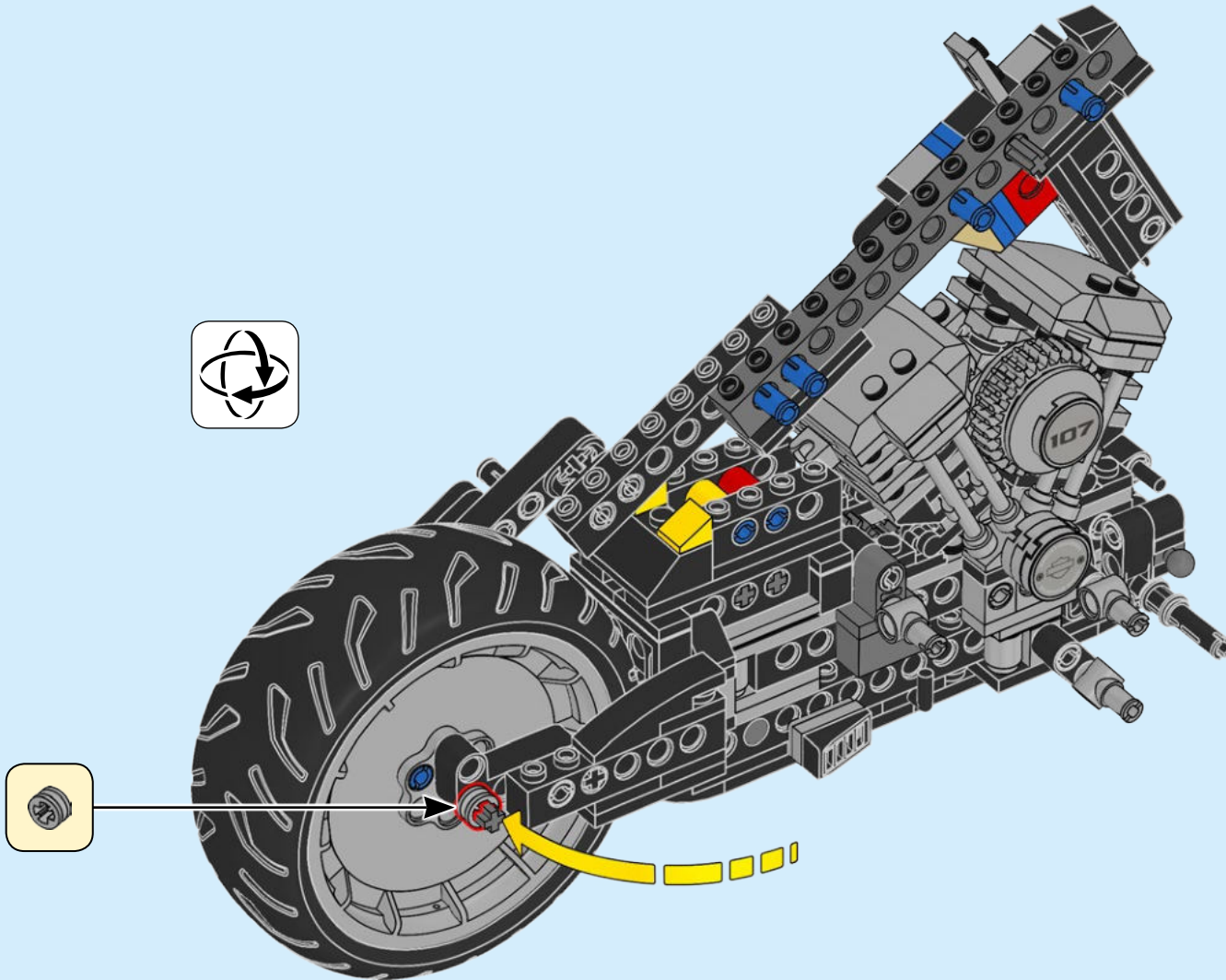



# LAKESTER RIM

The *Fat Boy*<sup>®</sup> motorcycle features an iconic cast aluminum front and rear wheel. Mani Zamani, Element Designer, created this piece specifically for this model. The element is designed in a way that it can be used on its own or doubled up in order to mount the rear tire.

The wide 240 mm rear tire is a key component of the *Fat Boy*<sup>®</sup> model's muscular stance. For the LEGO<sup>®</sup> *Harley-Davidson*<sup>®</sup> *Fat Boy*<sup>®</sup> motorcycle, Mani developed a 35 mm tire, the widest motorcycle tire ever made in LEGO bricks.



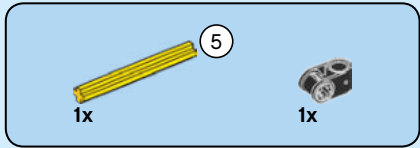

83

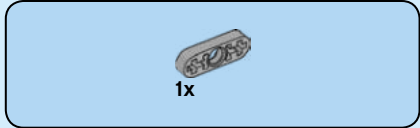
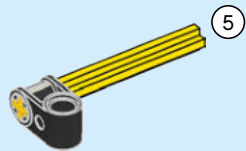

84

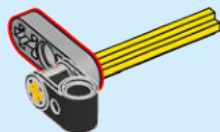

85

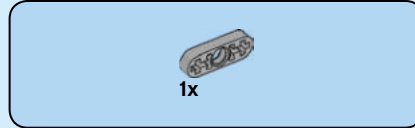
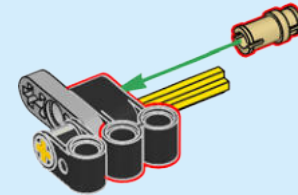

86

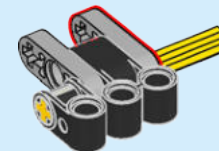

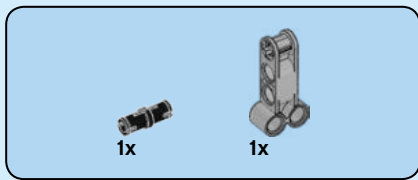

87

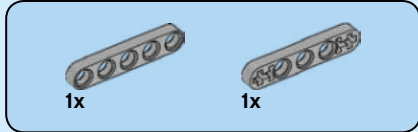
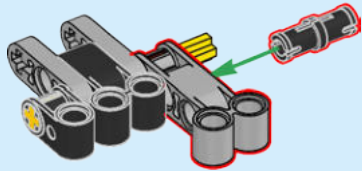

88

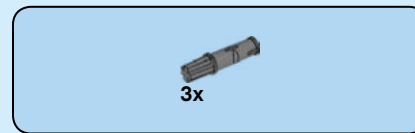
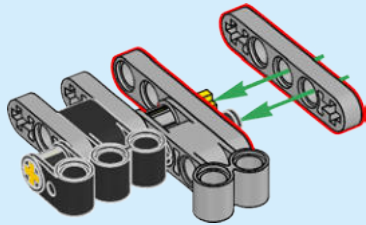

89

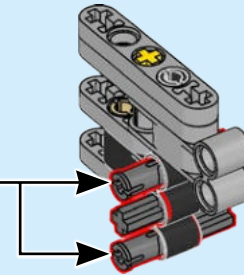
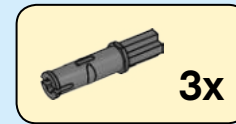
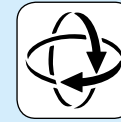

90

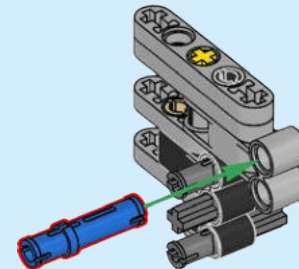

91

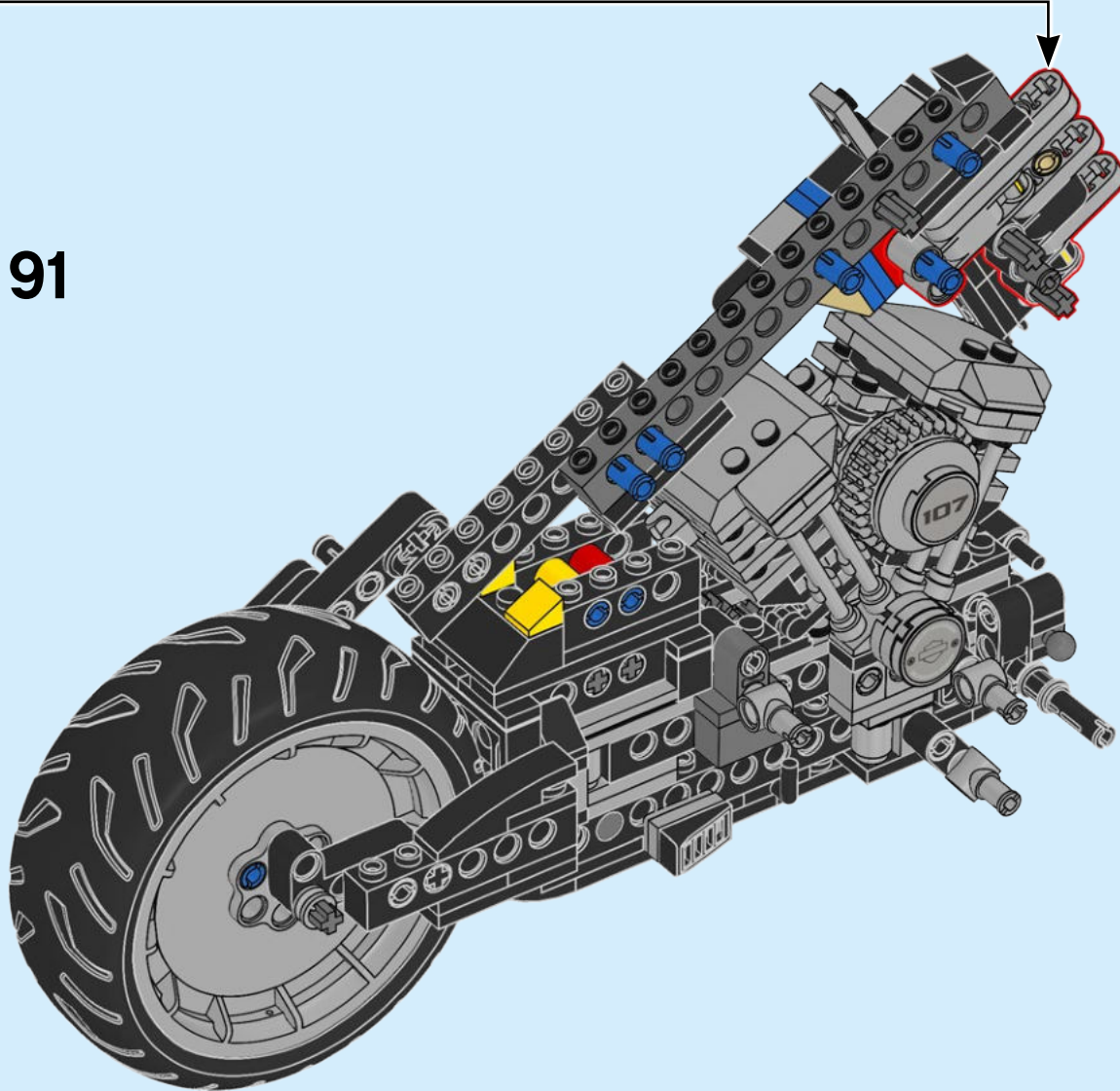



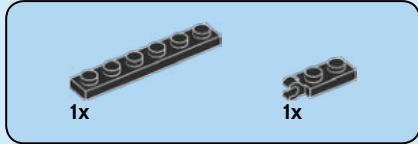
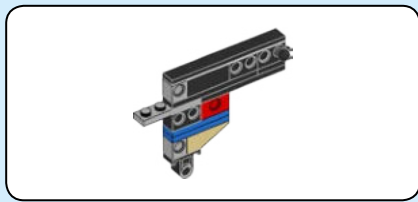

92

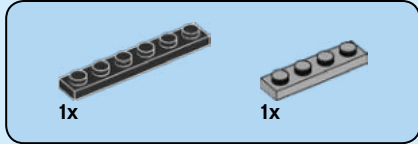
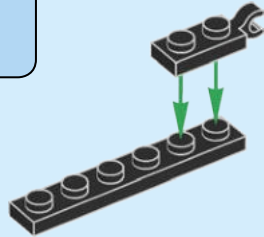

93

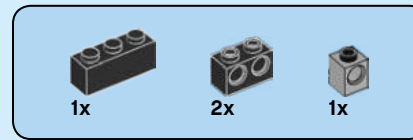
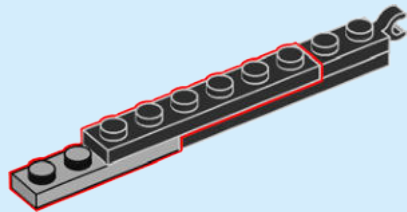

94

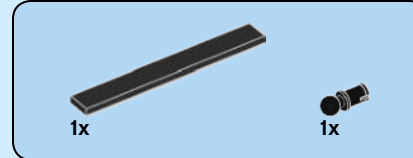
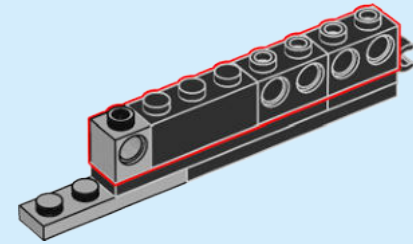

95

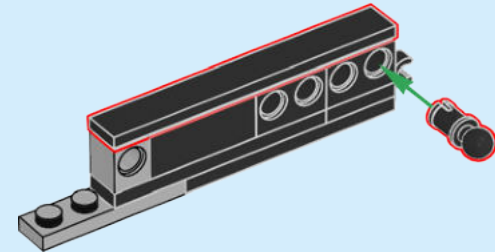

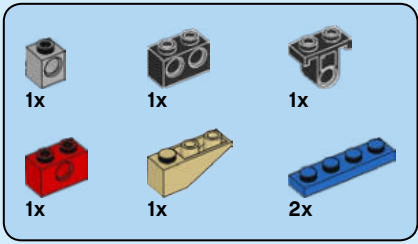

# 96

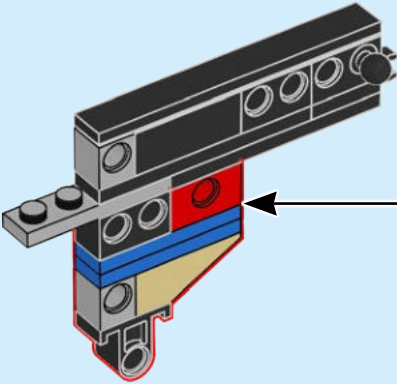
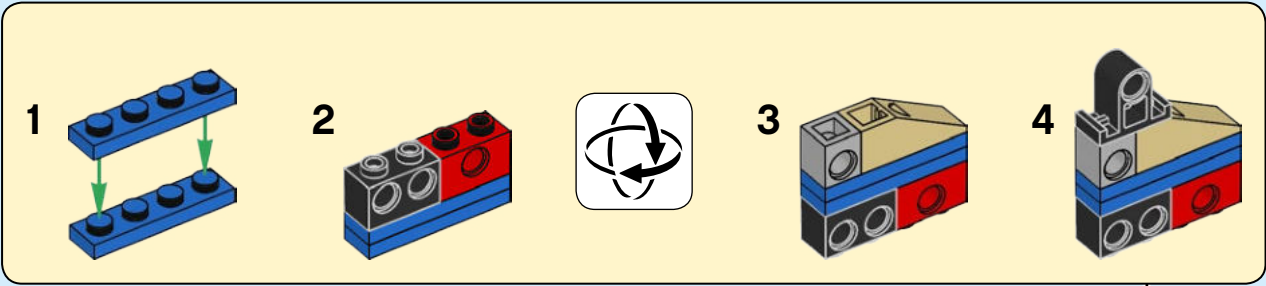

97

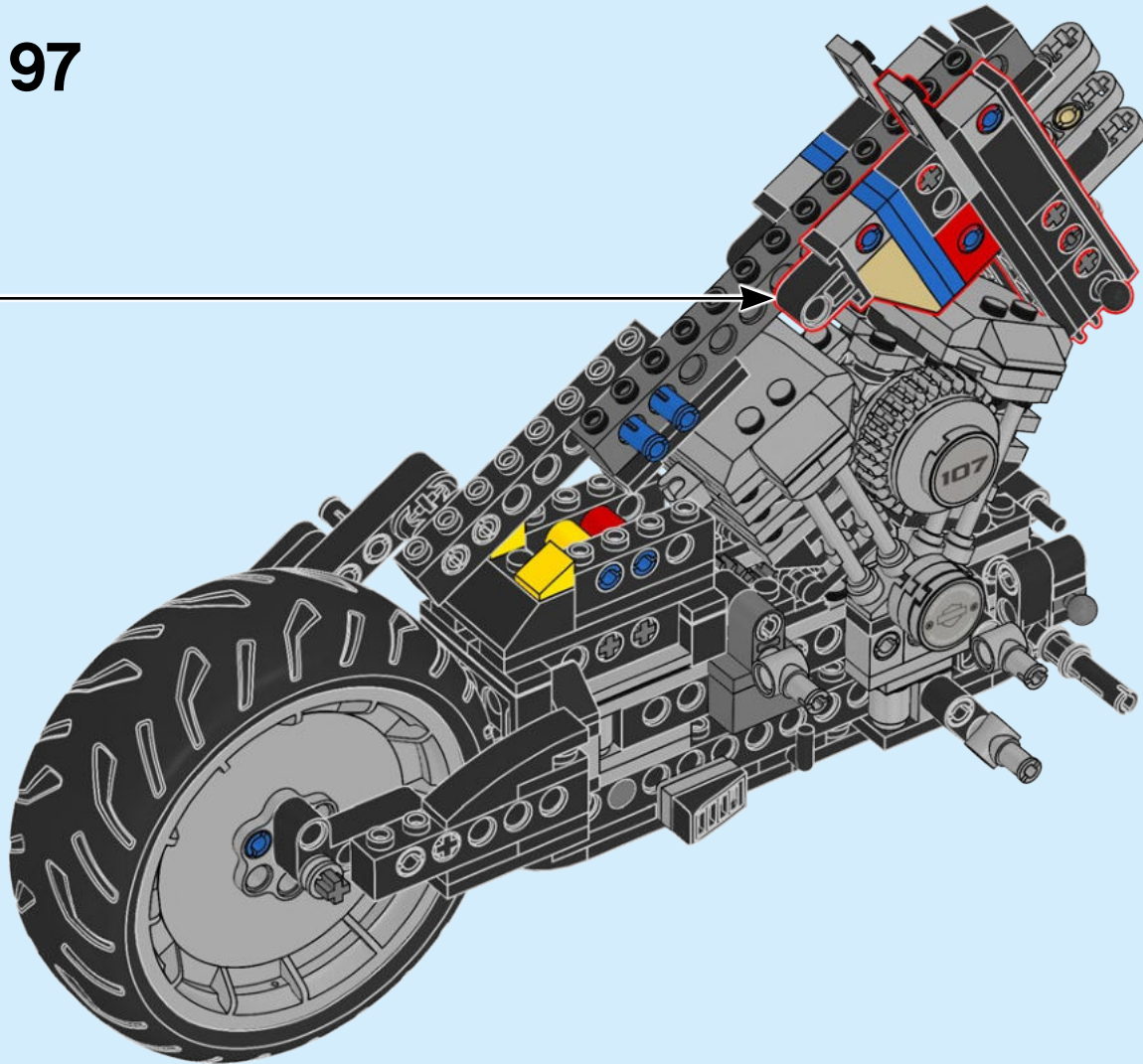



43x

98

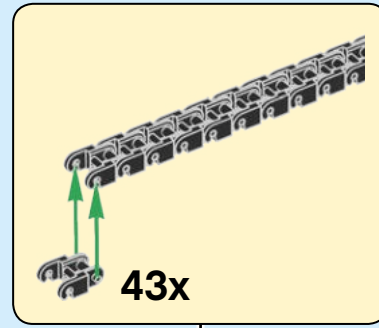
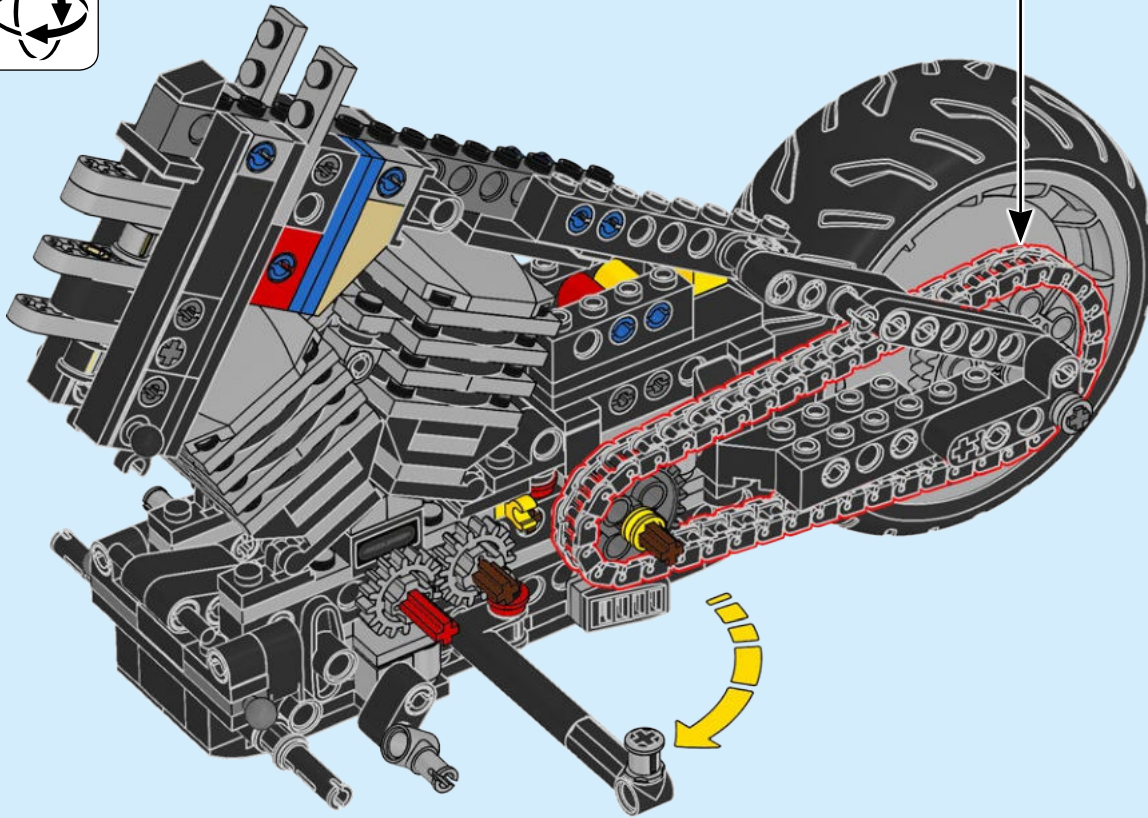

43x



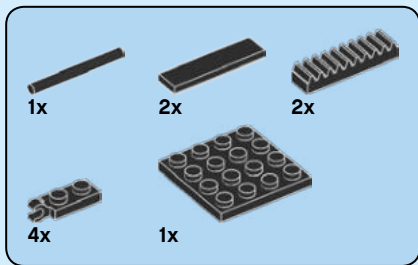

99

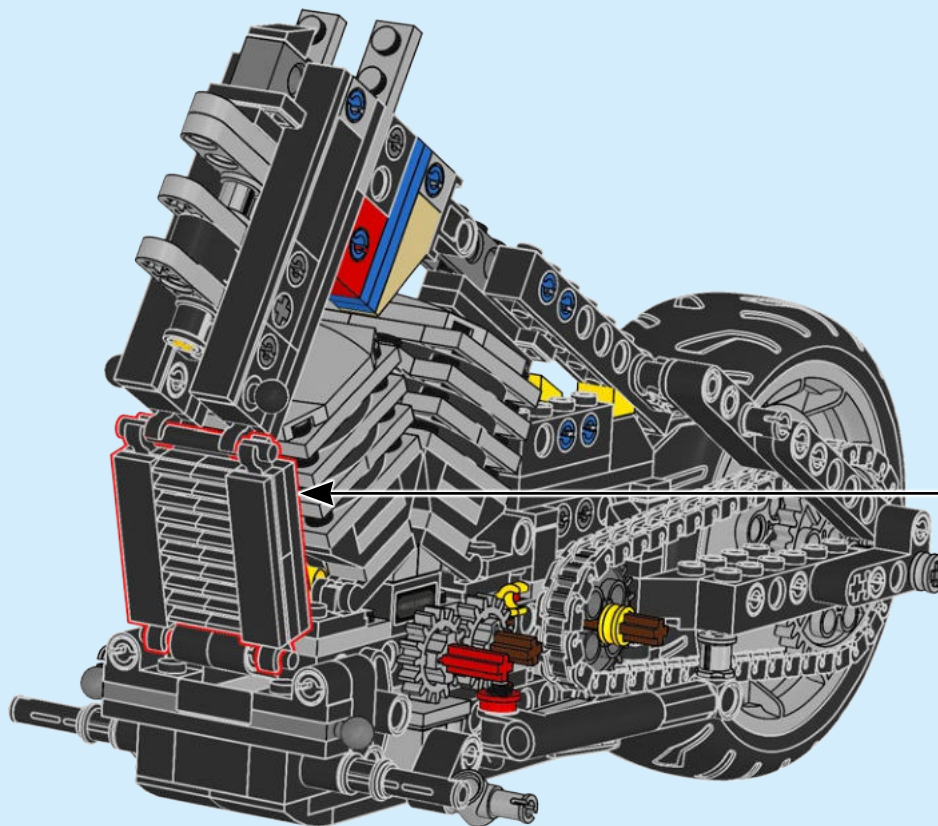
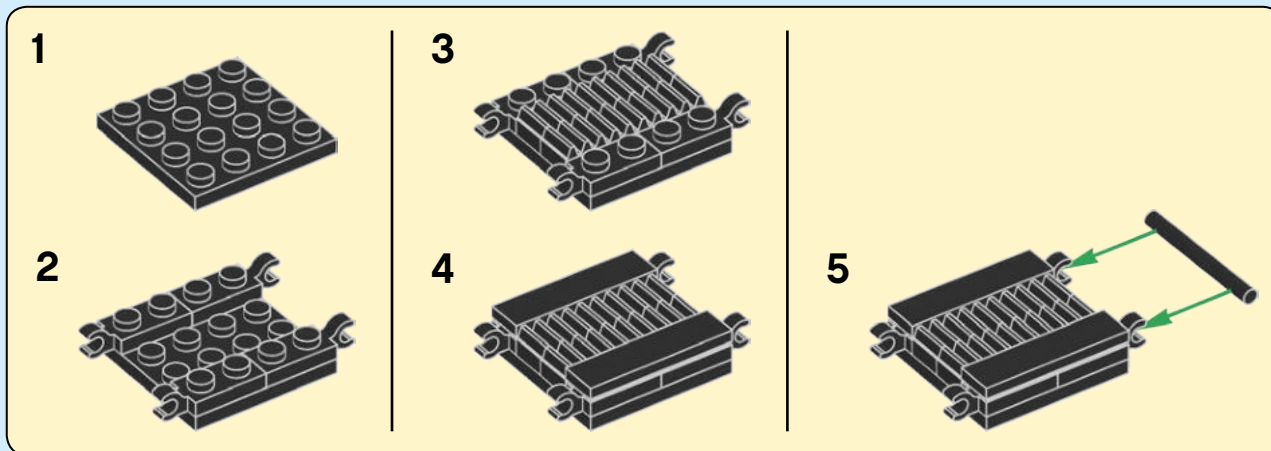

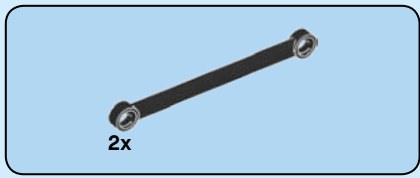

100

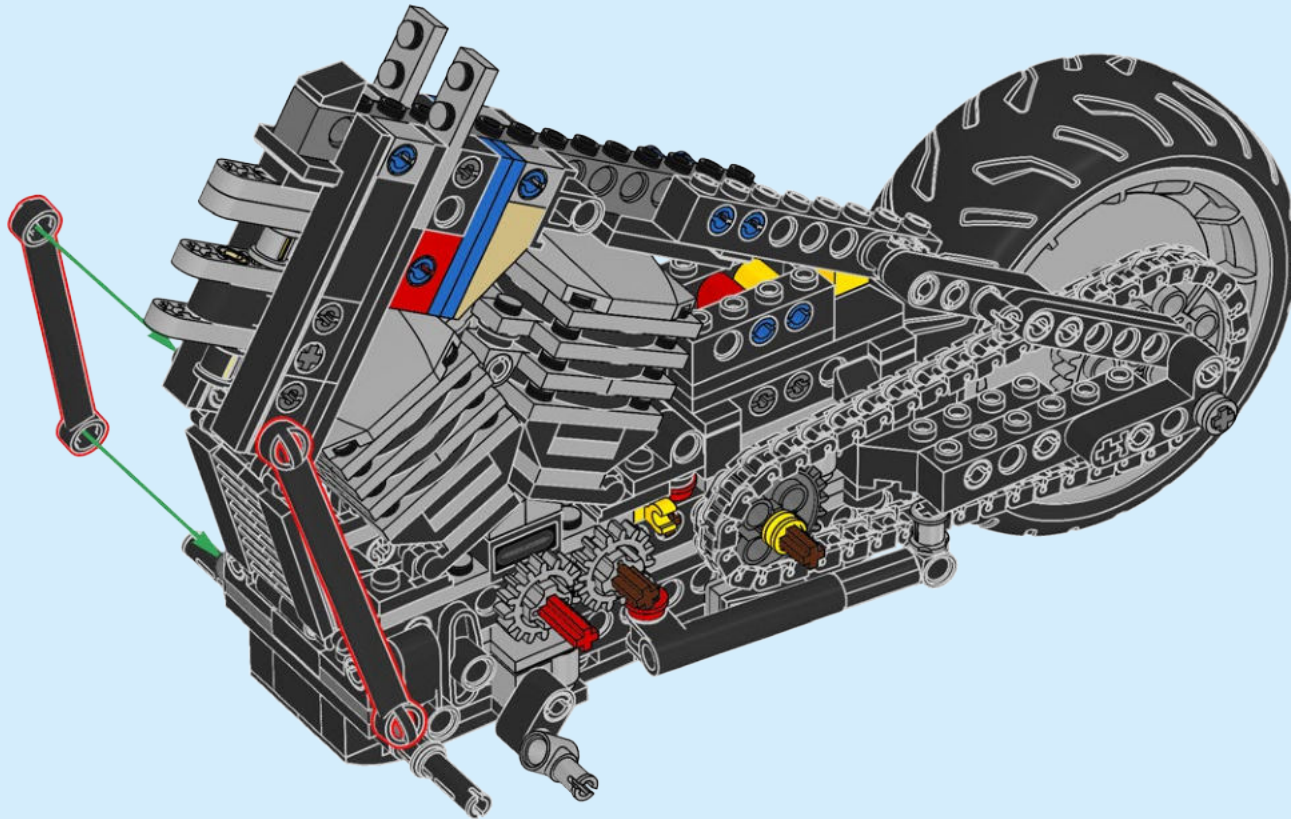

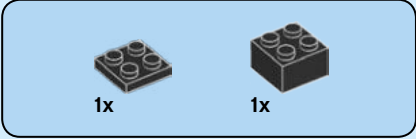

101

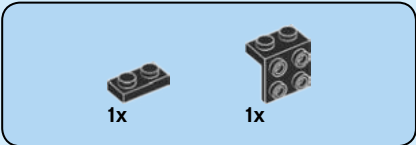
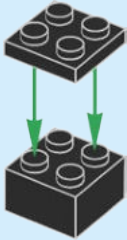

102

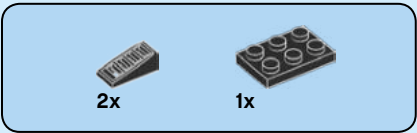
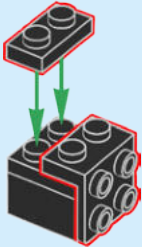

103

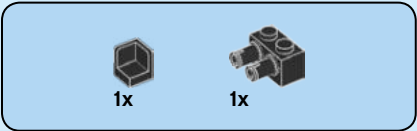
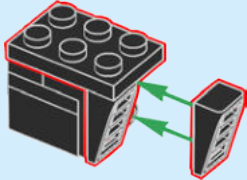

104

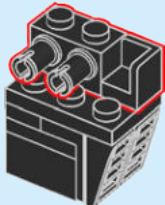

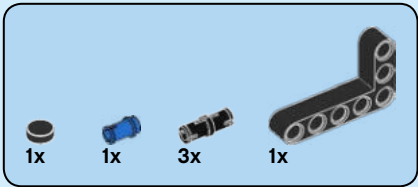

# 105

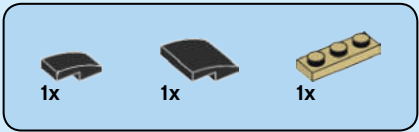
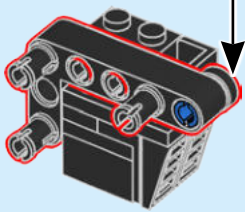
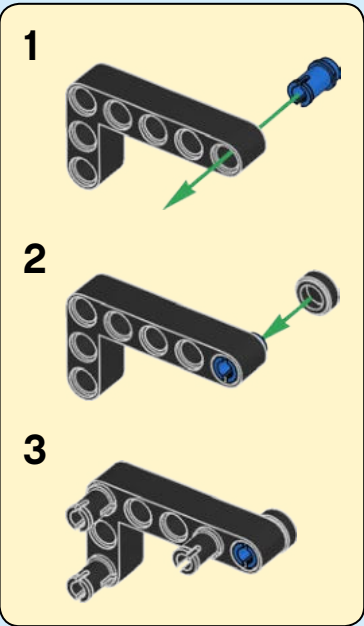

# 106

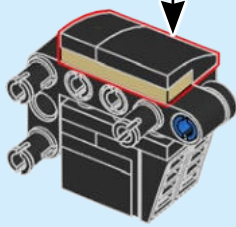
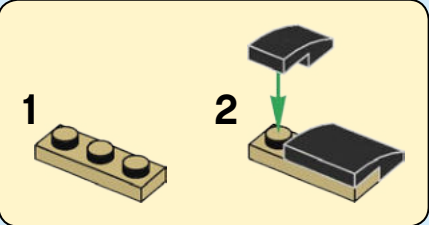



107

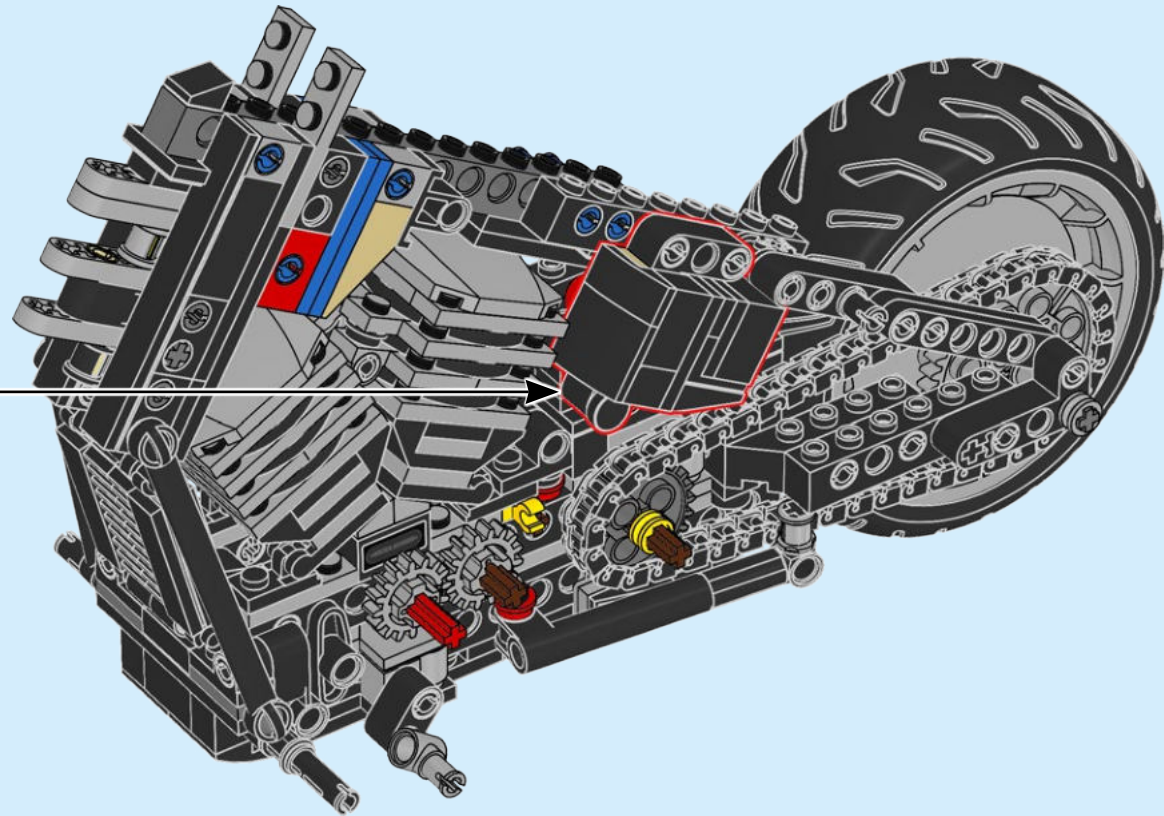

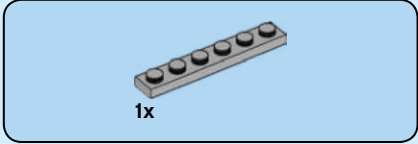
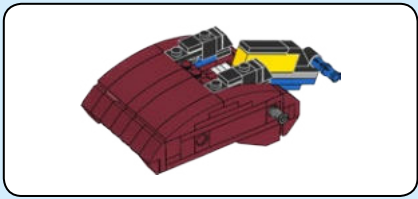

108

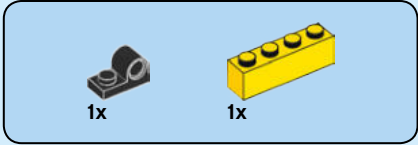
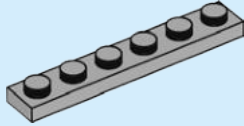

109

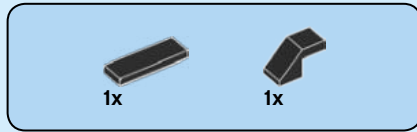
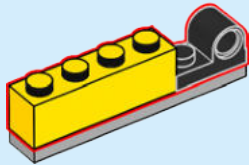

110

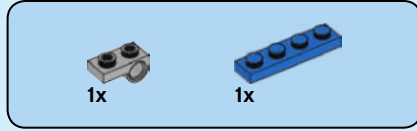
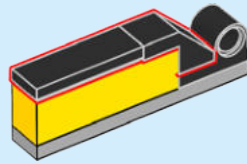

111

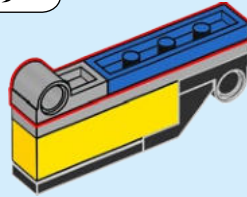

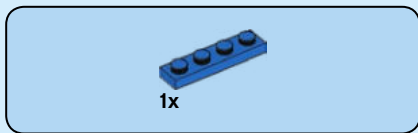

112

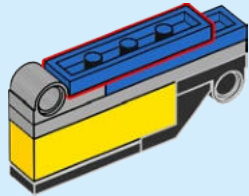

113

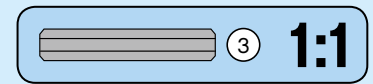
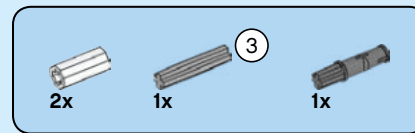
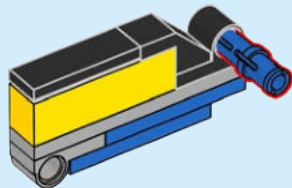

114

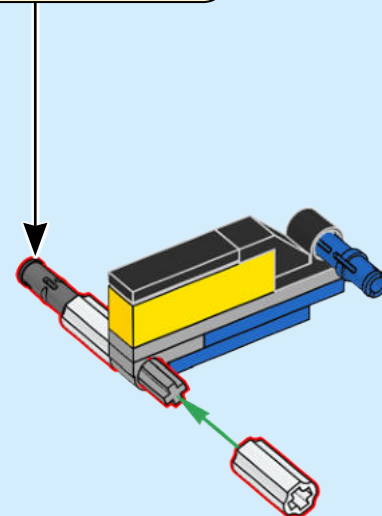
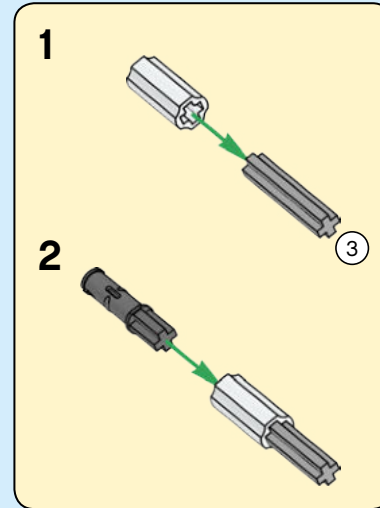

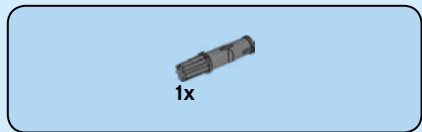

115

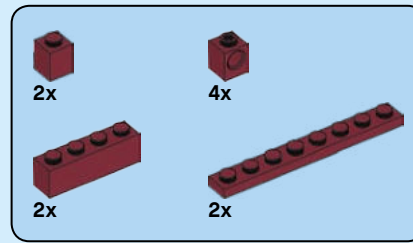
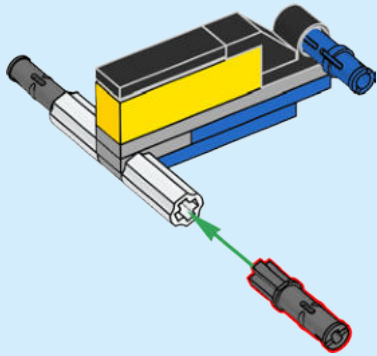

116

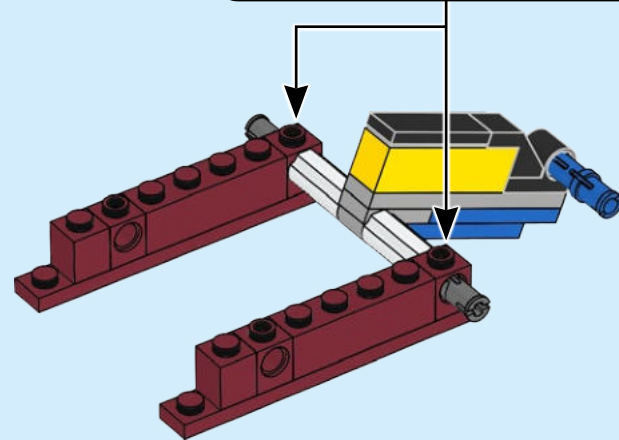
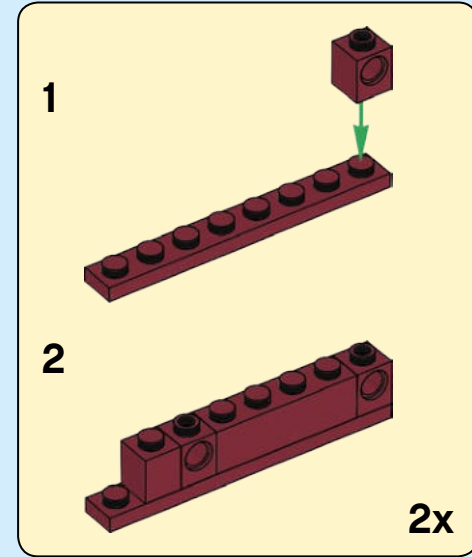



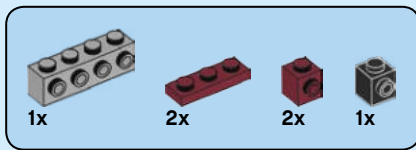

117

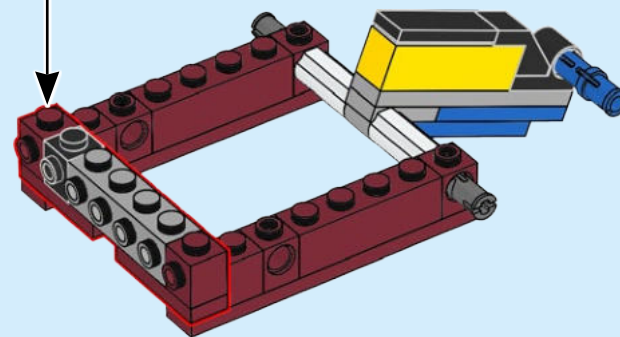
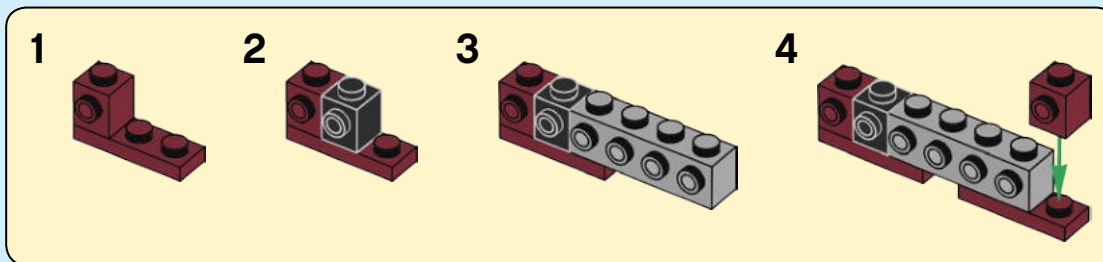

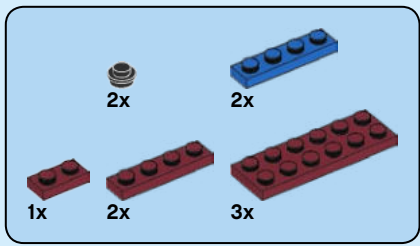

118

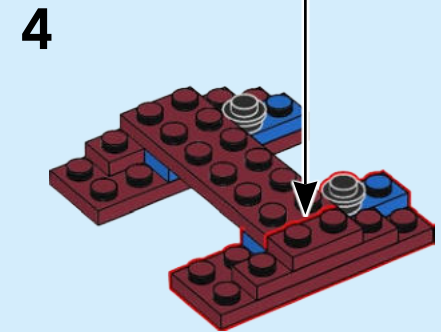
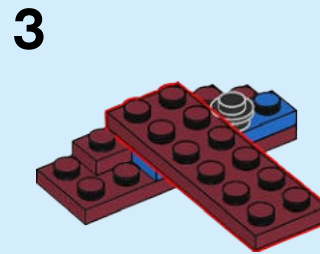
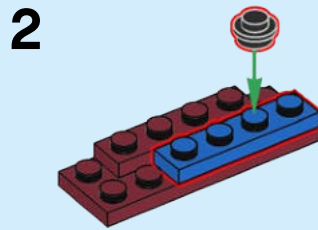
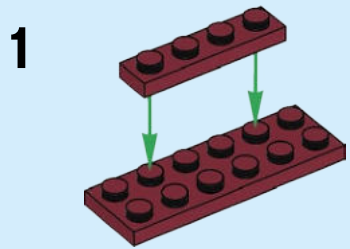
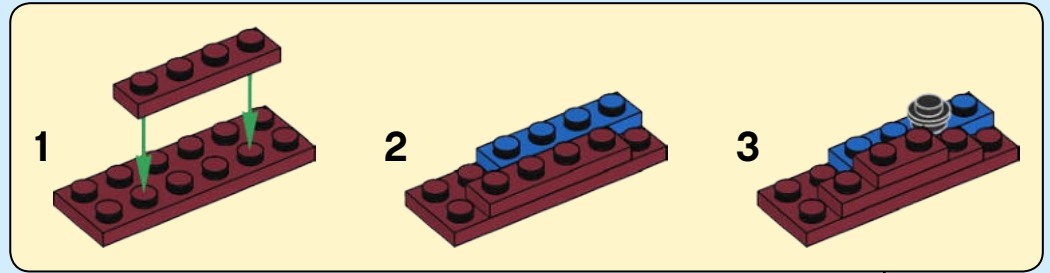

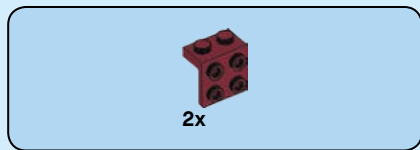

119

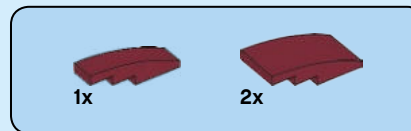
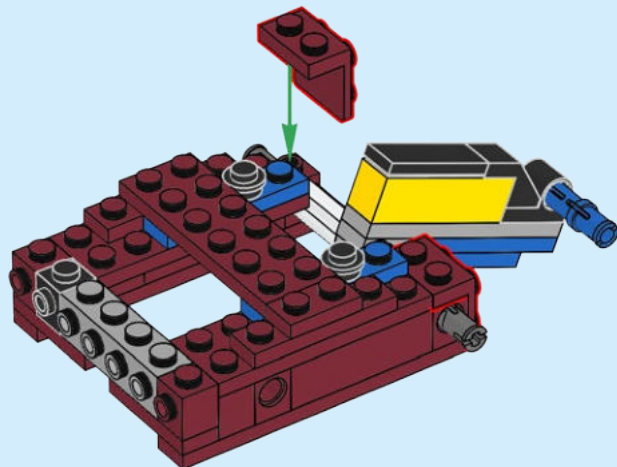

120

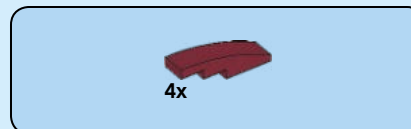
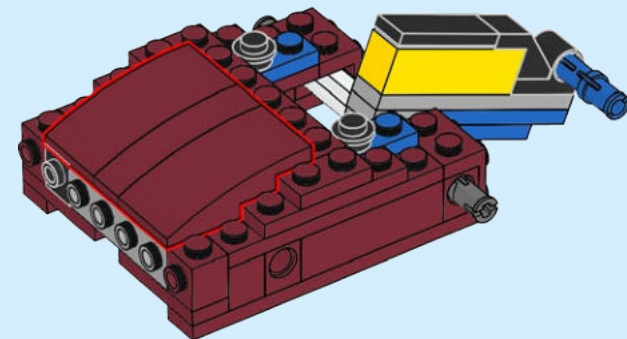

121

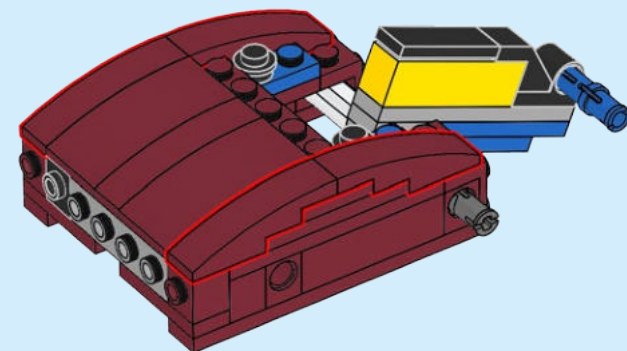

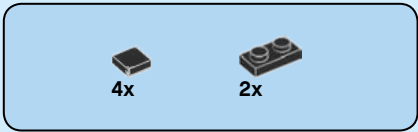

122

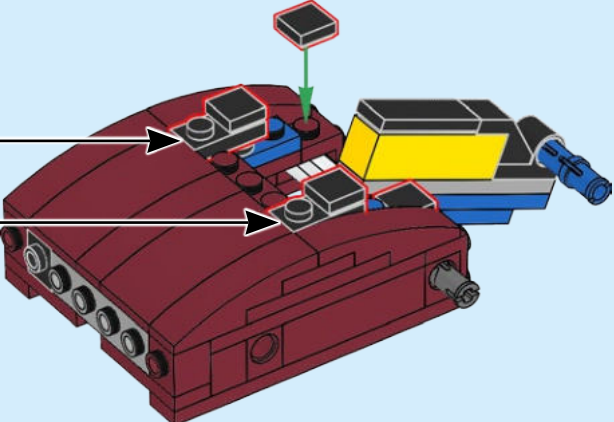
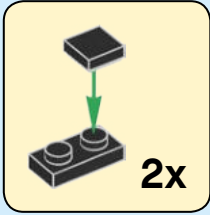

123

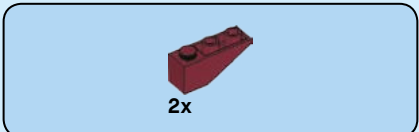
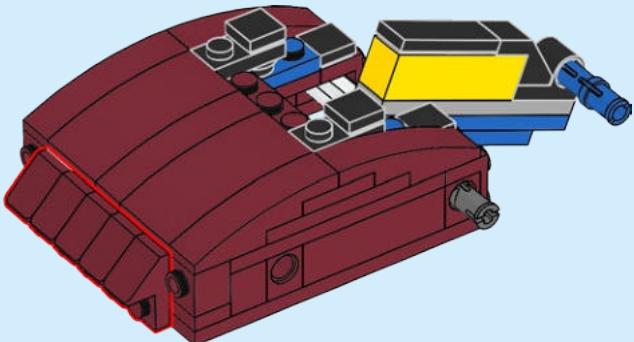

124

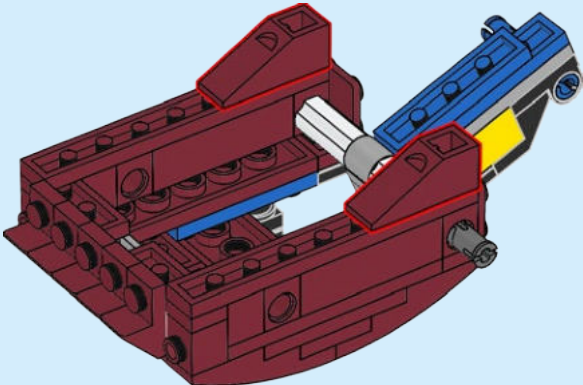

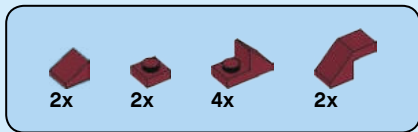

125

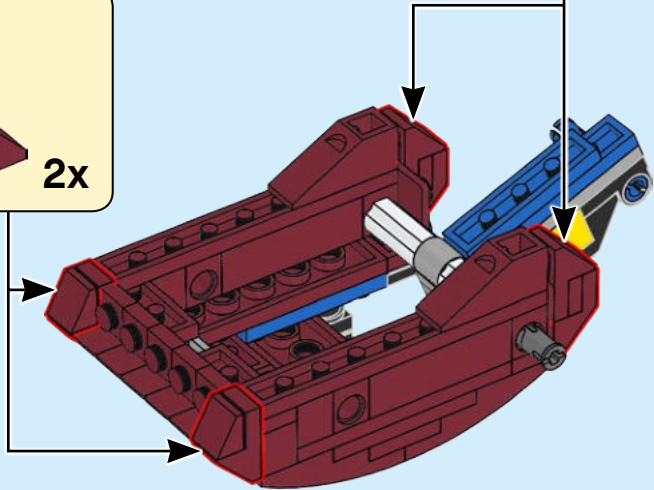
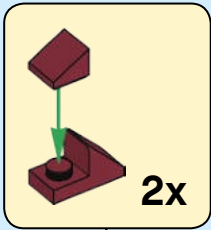
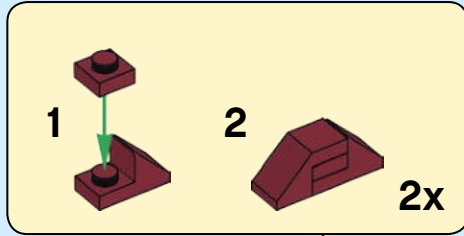

126

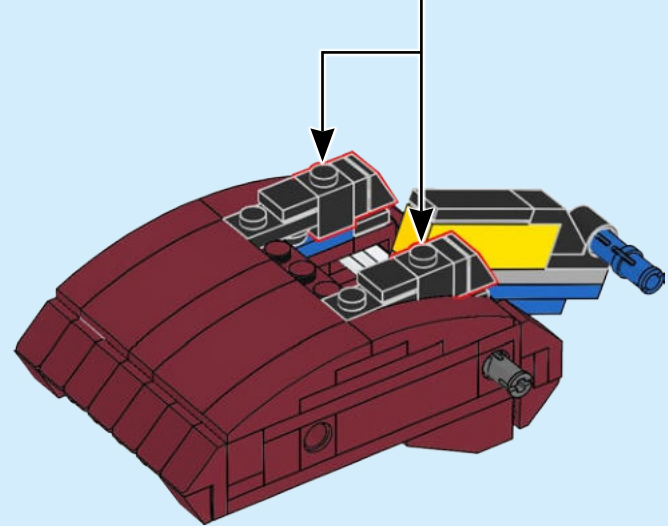
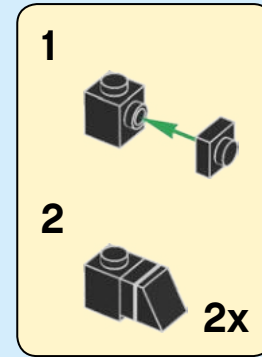
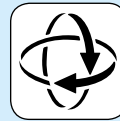



127

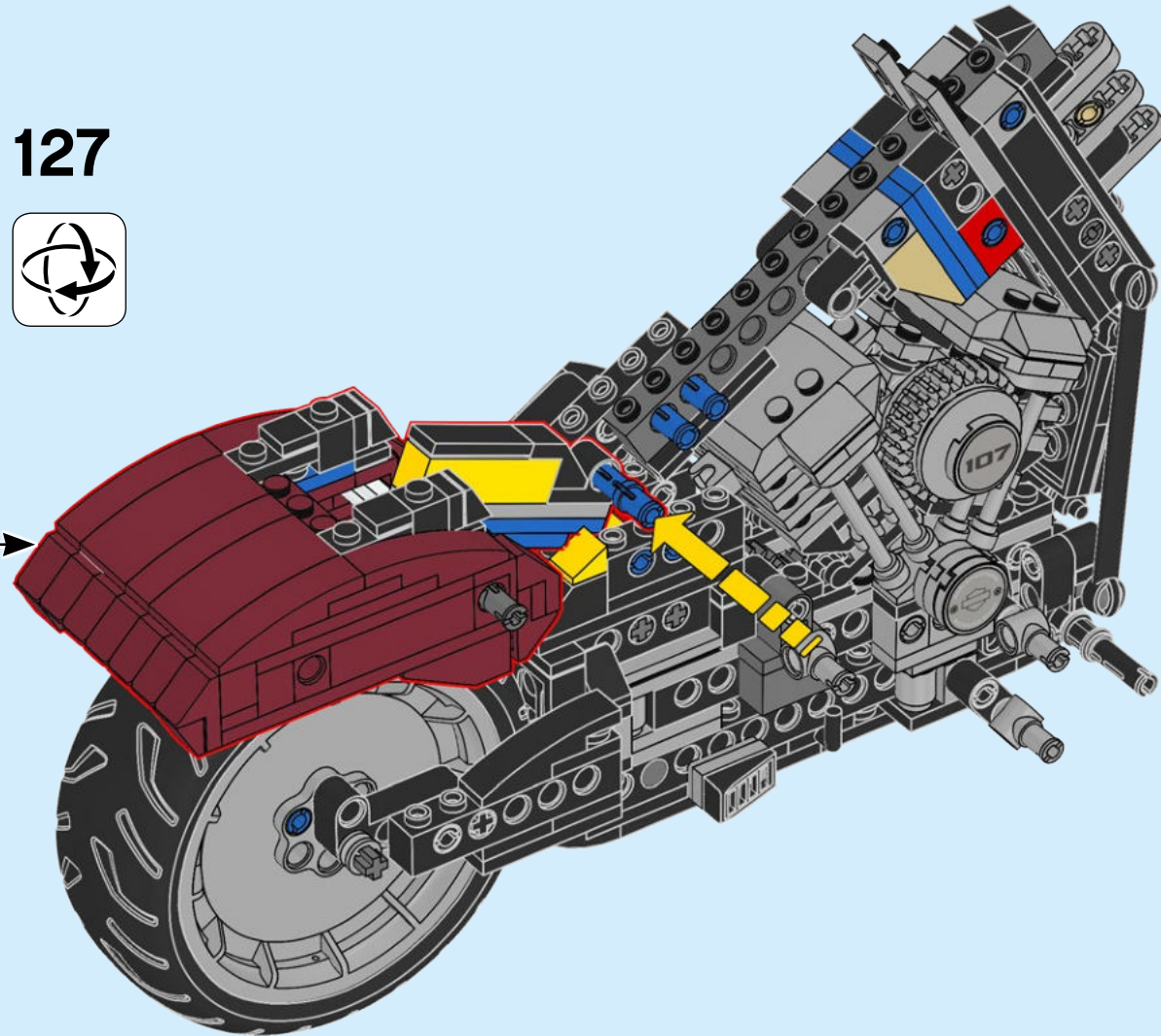

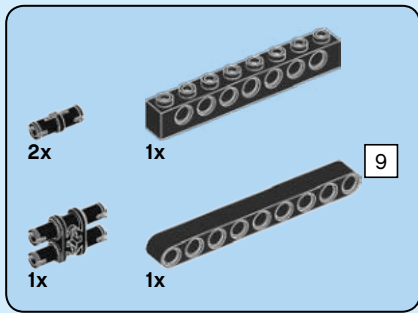

128

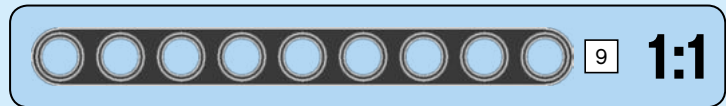
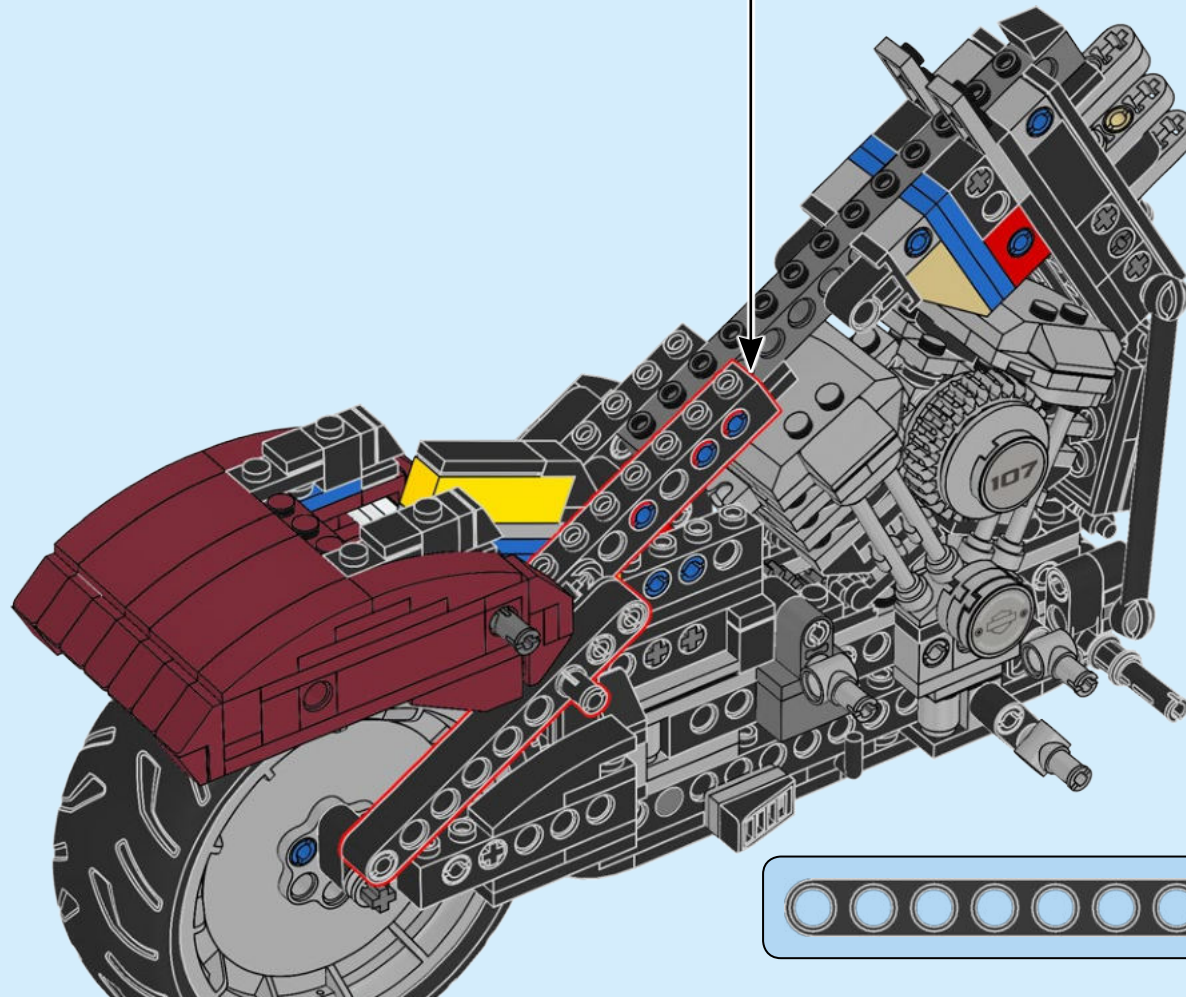
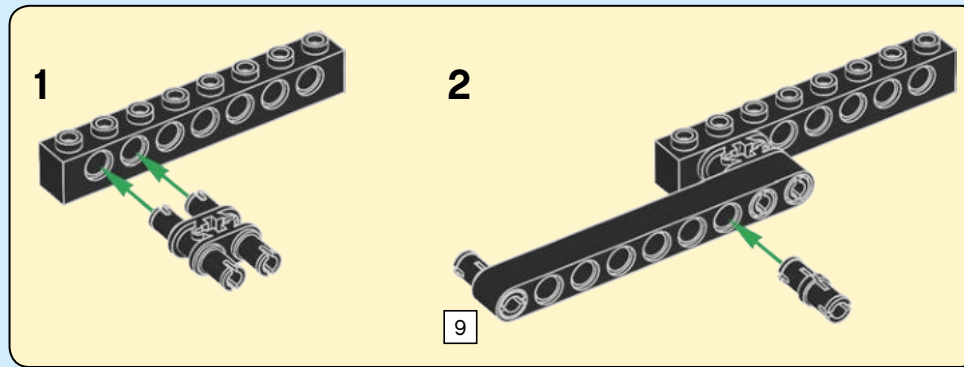

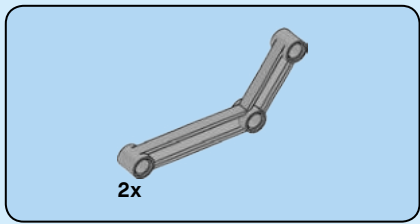

129

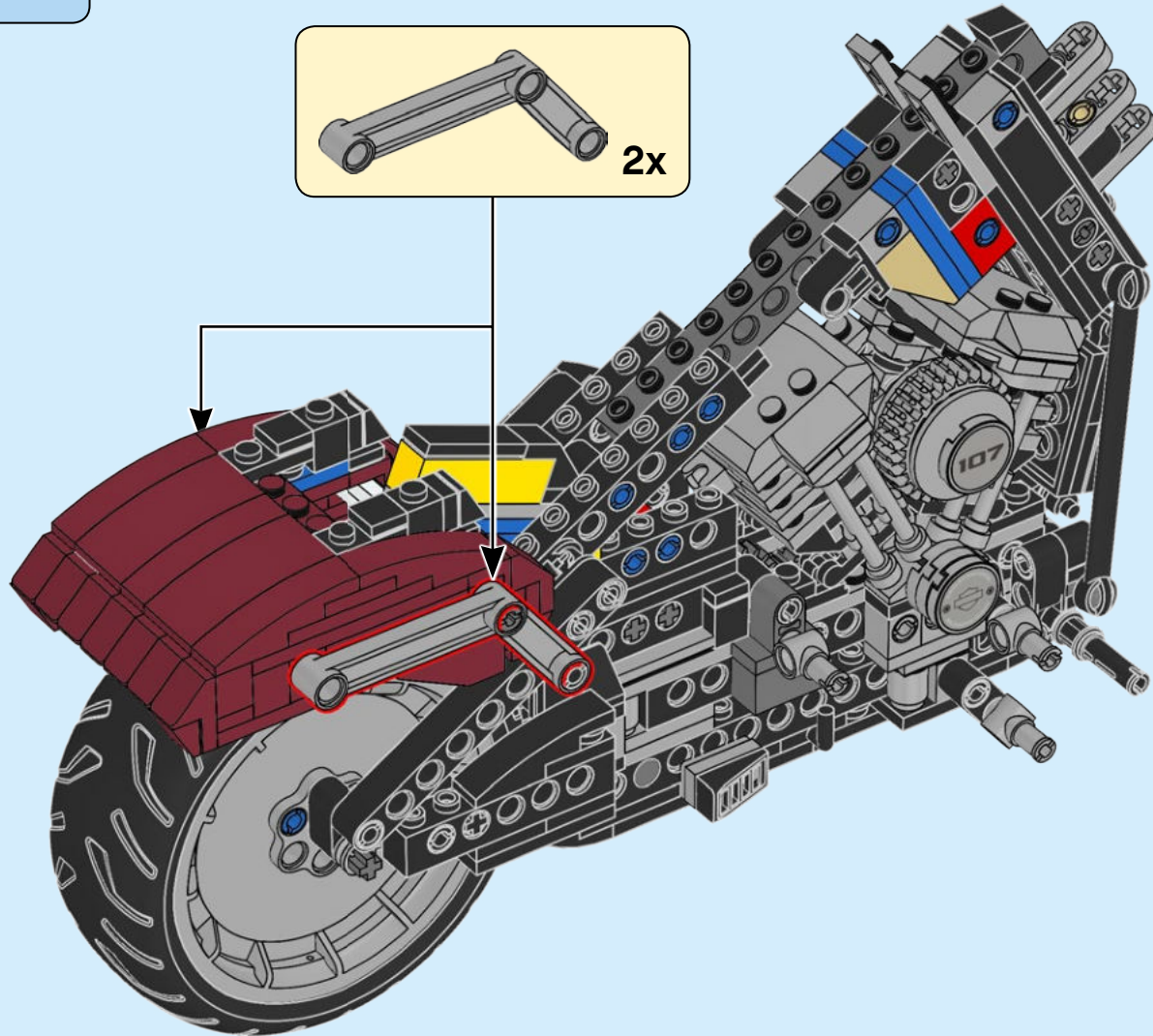
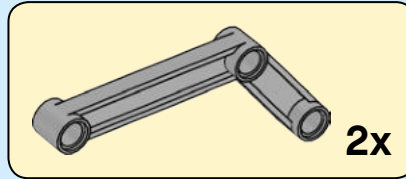





# 130

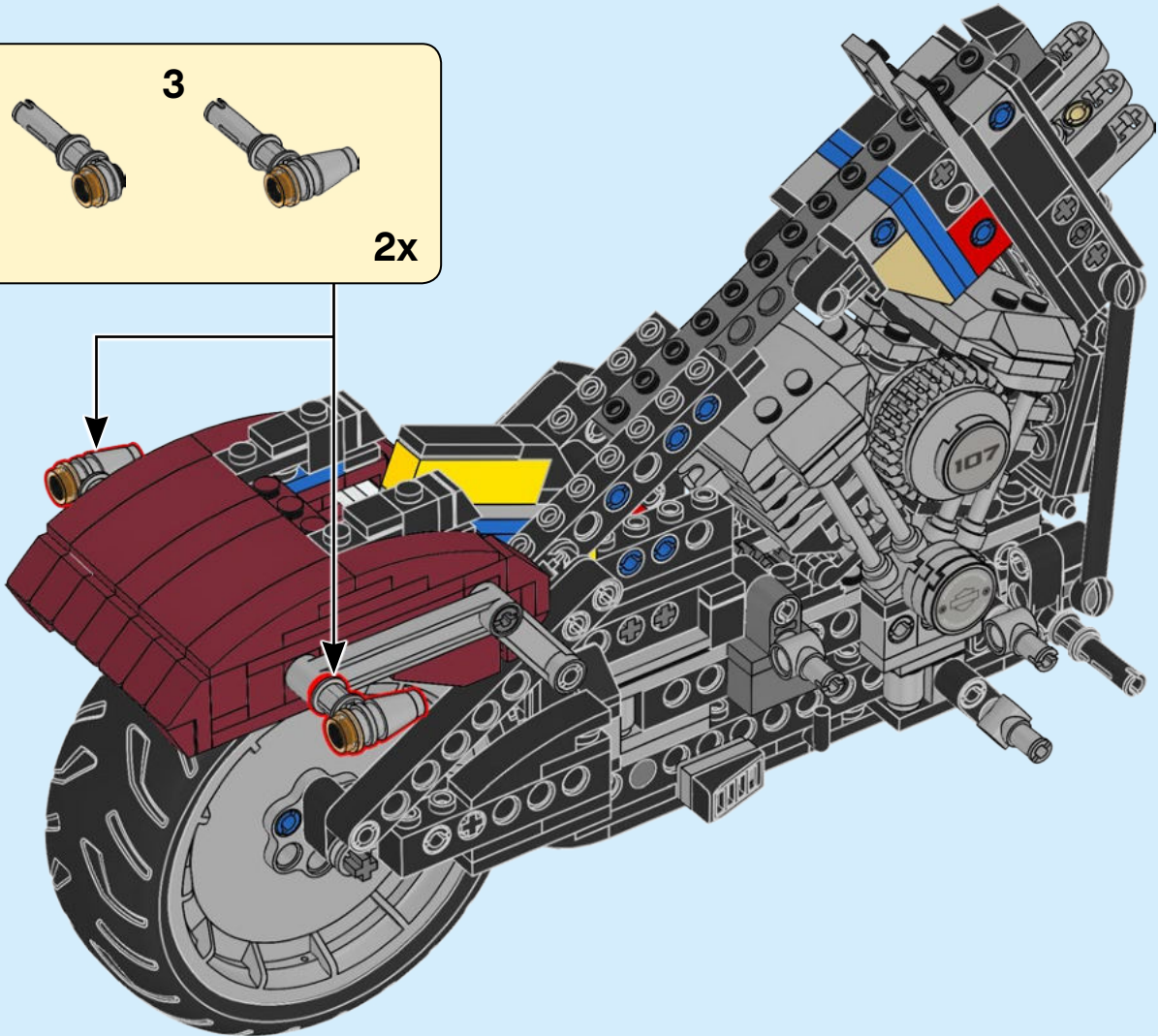
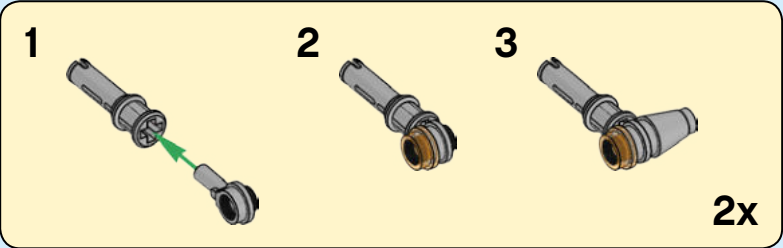

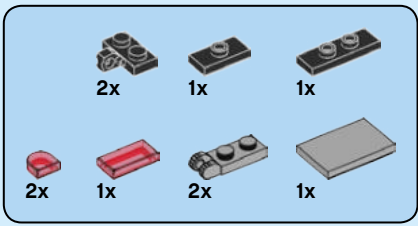

# 131

1

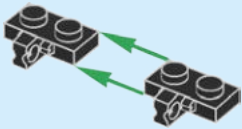

2



3

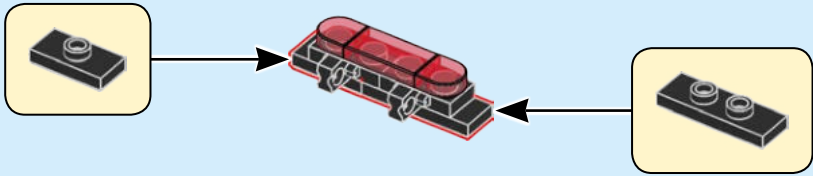

4

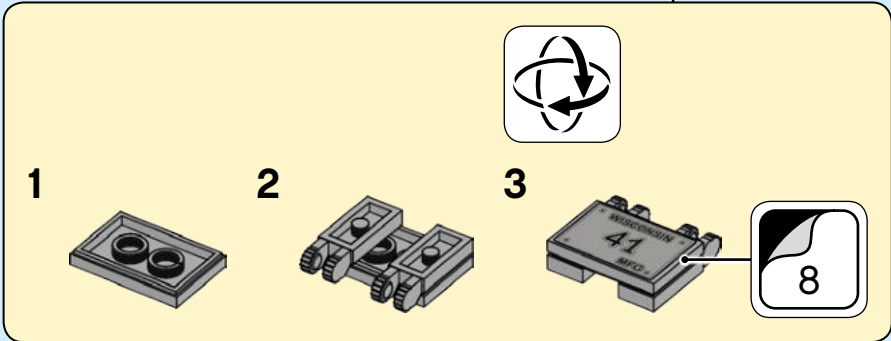
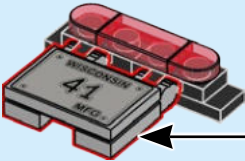



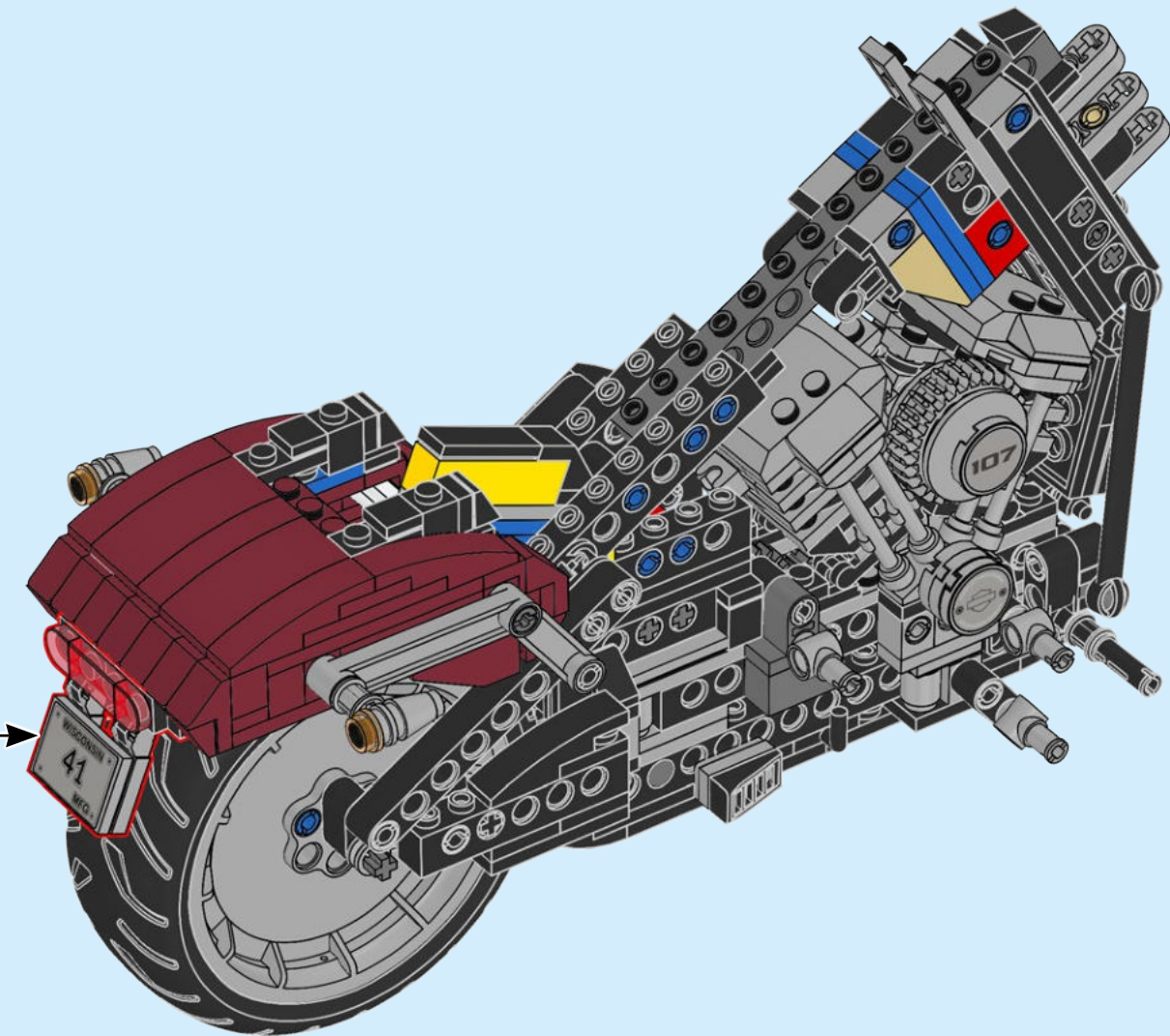

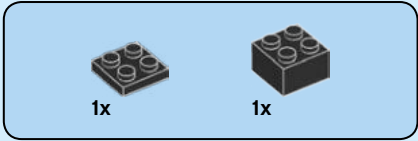

132

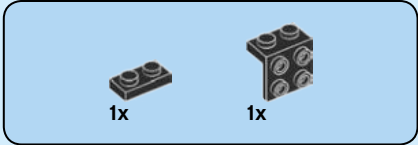
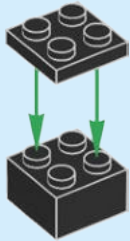

133

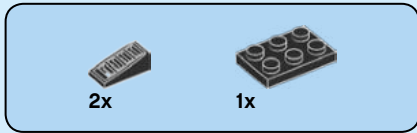
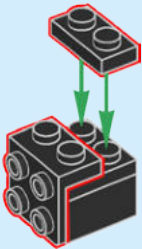

134

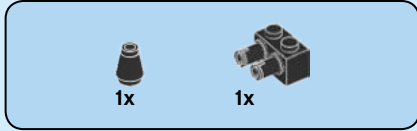
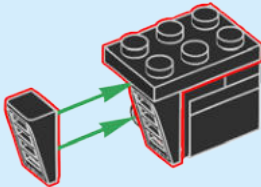

135

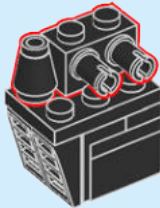

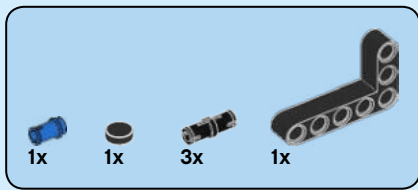

136

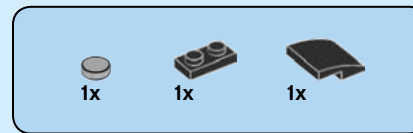
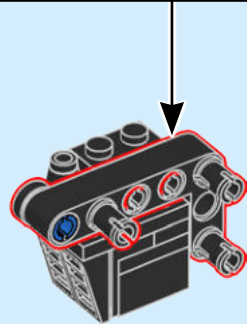
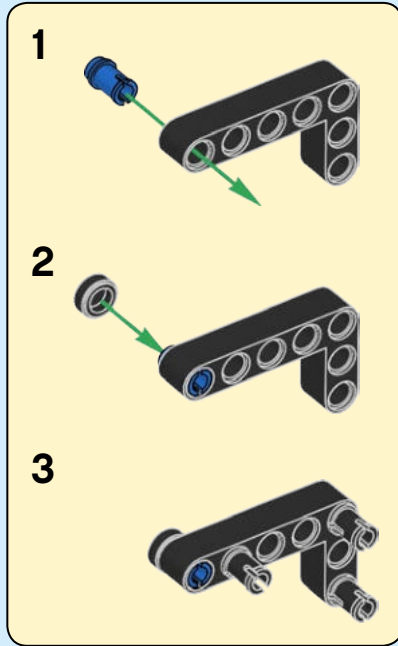

137

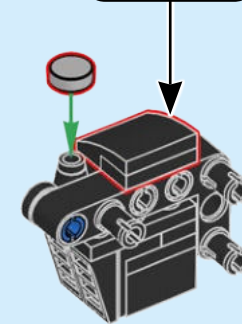
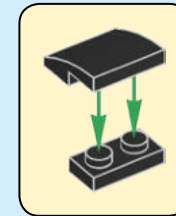

138

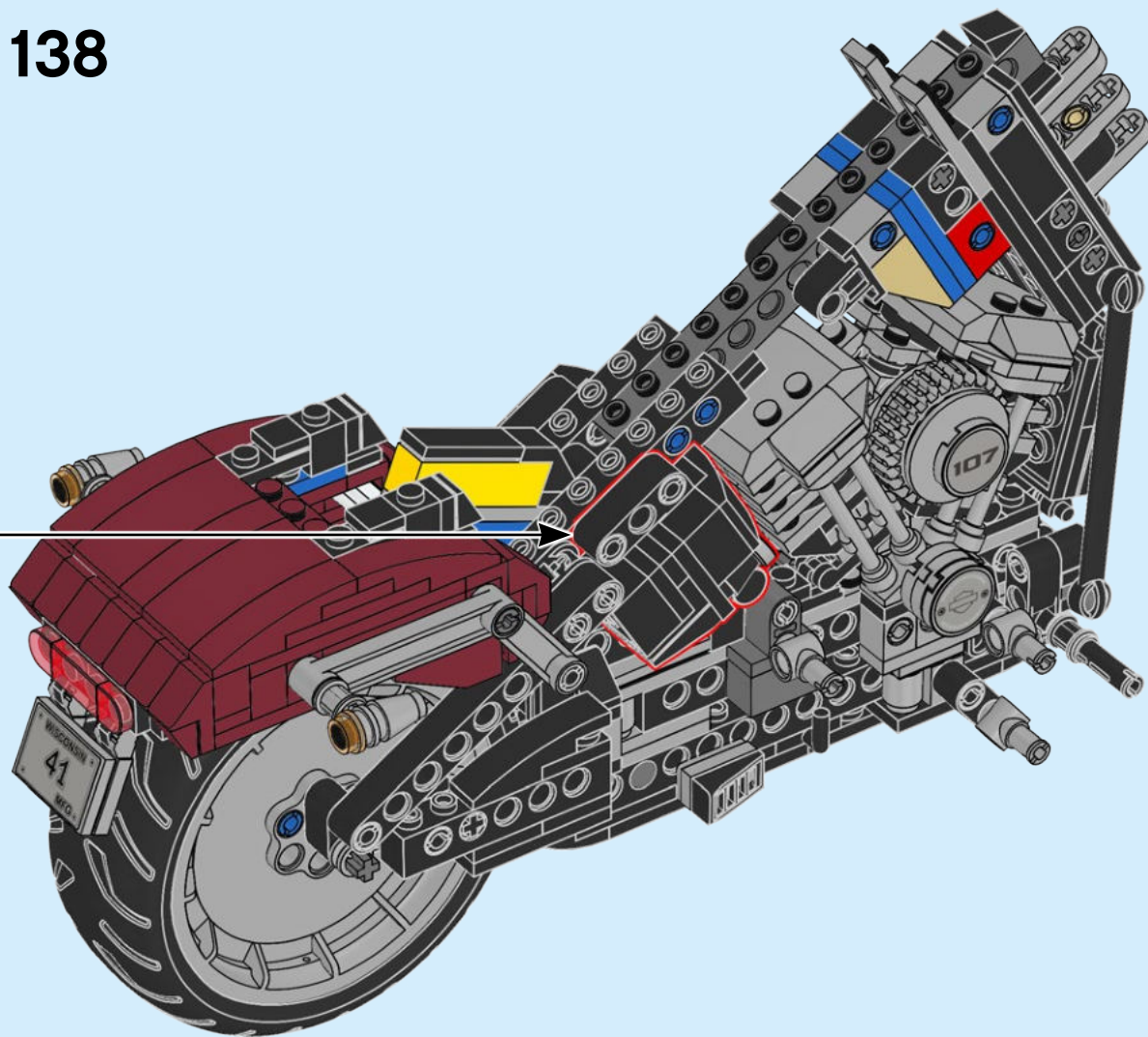

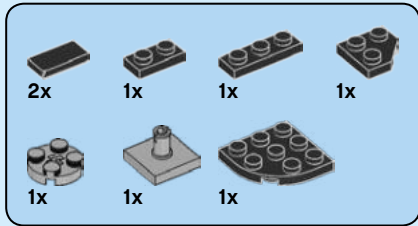
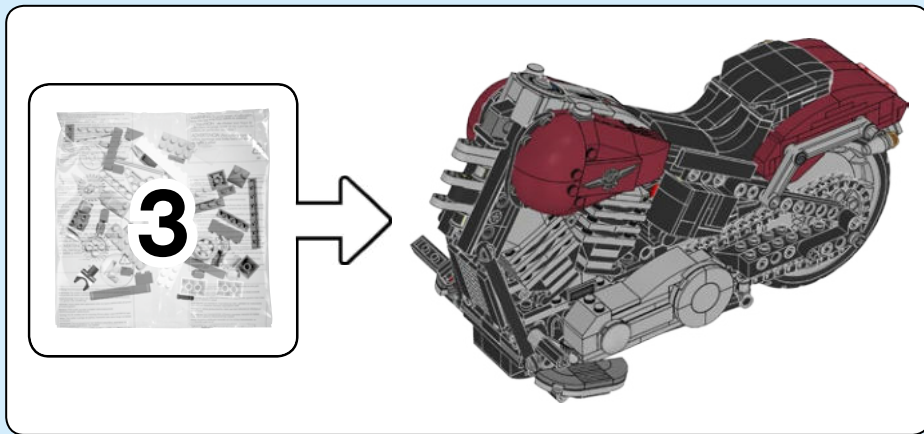

139

1

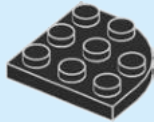

2

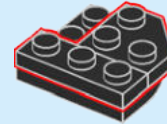

3

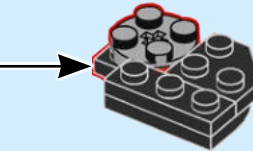
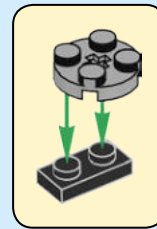

4

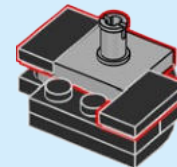



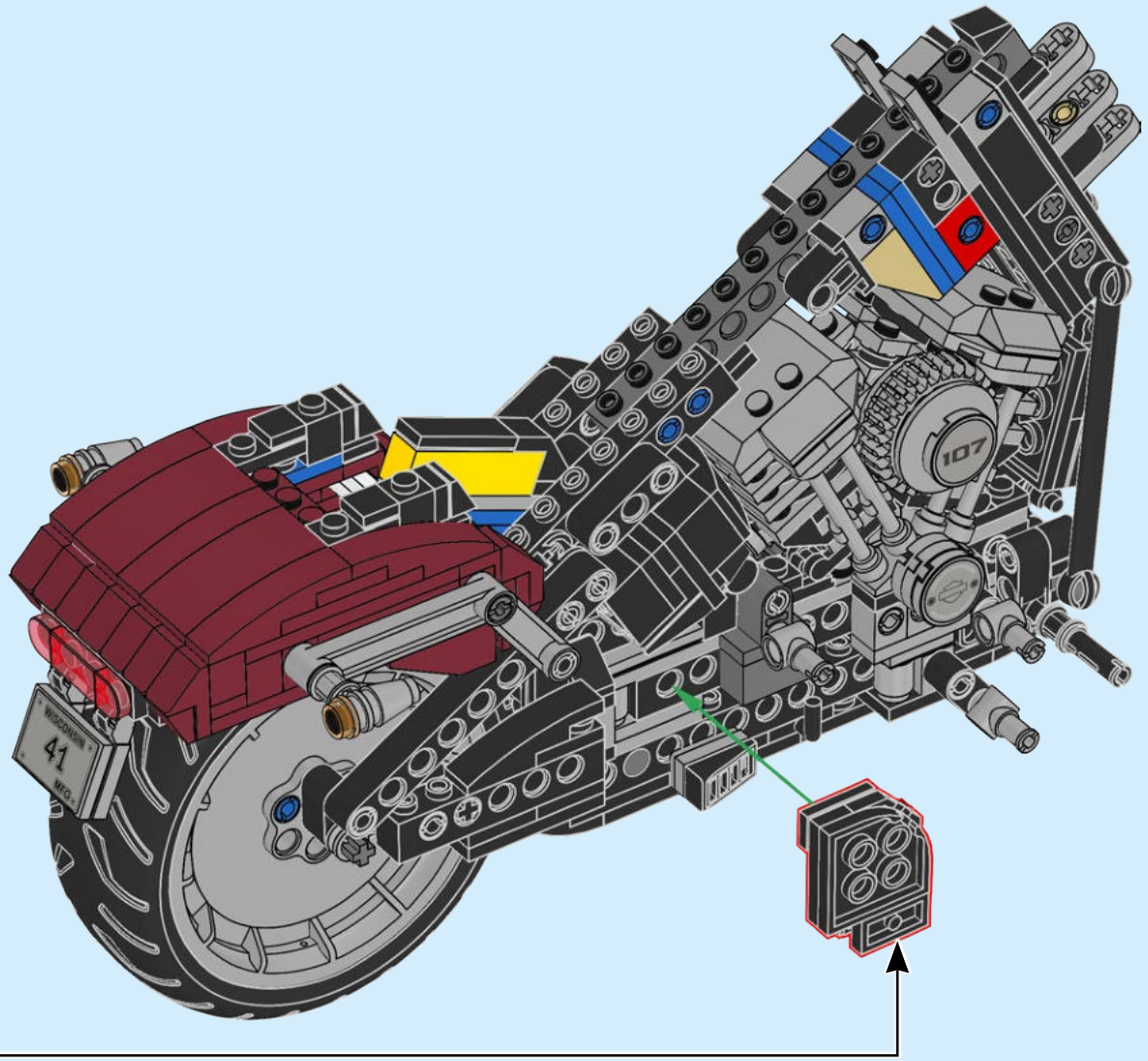

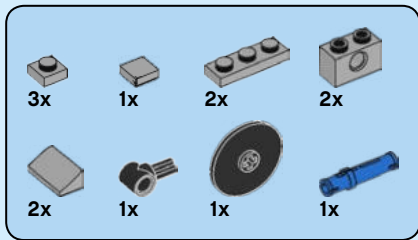

# 140

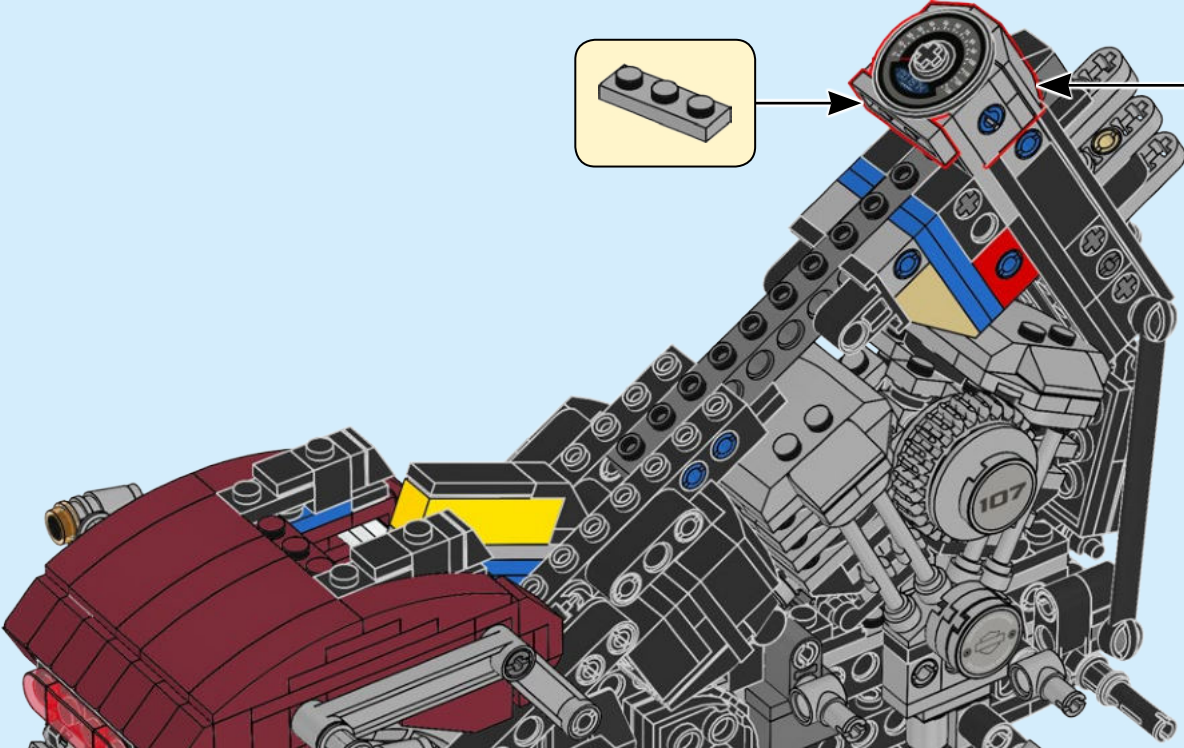
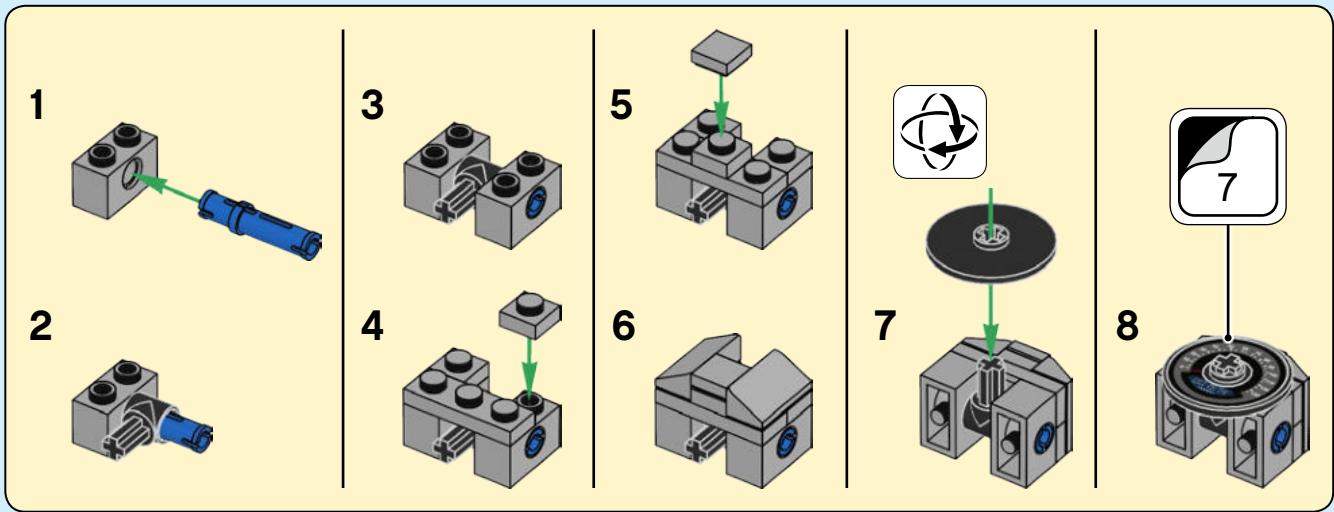

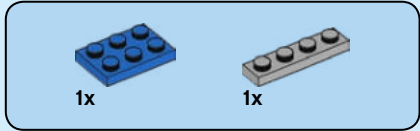
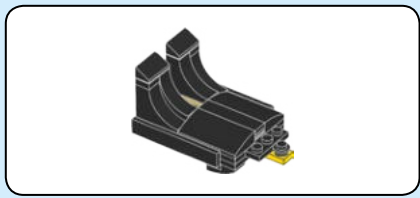

141

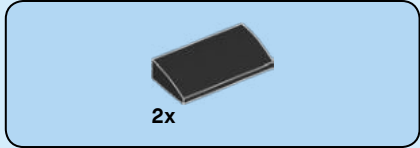
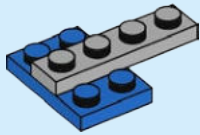

142

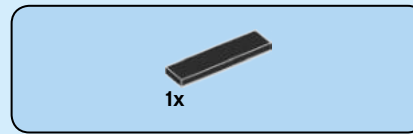
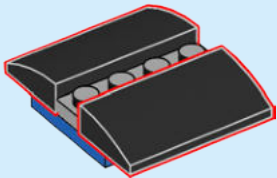

143

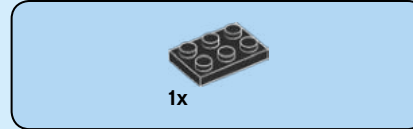
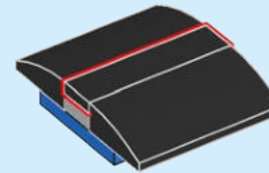

144

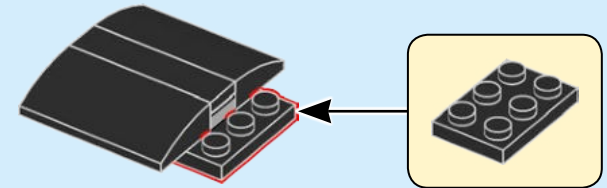

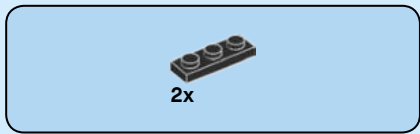

145

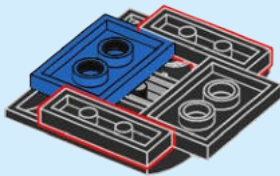

146

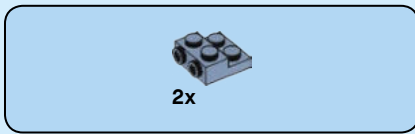
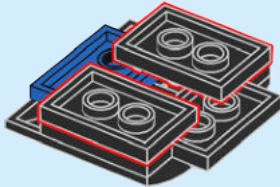

147

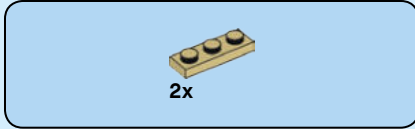
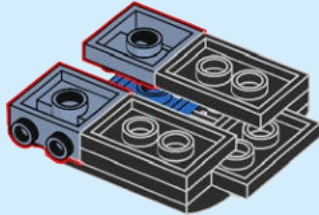

148

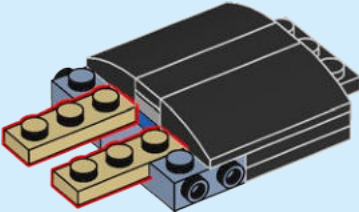

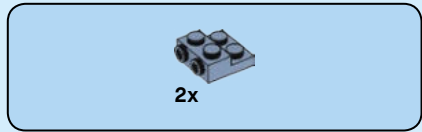

149

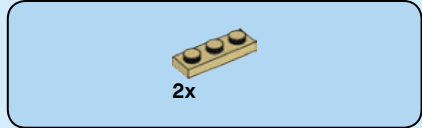
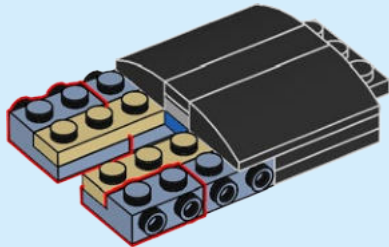

150

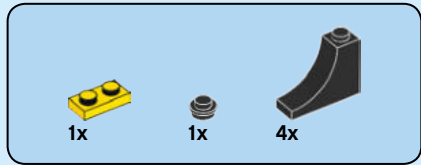
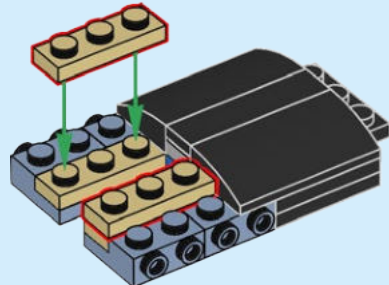

151

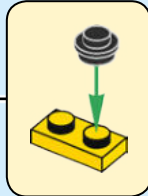
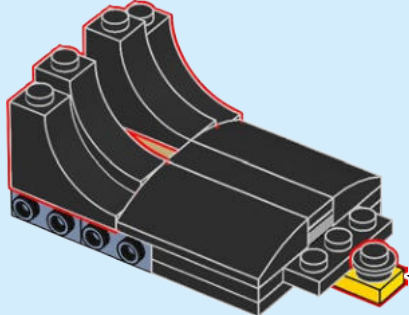

152

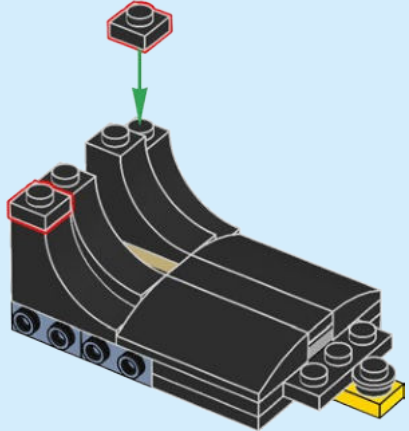





153

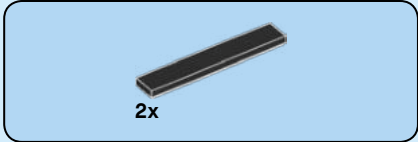
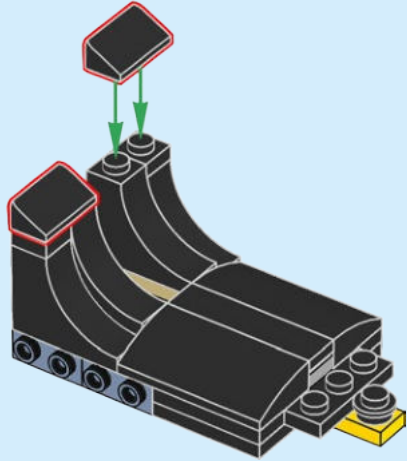

154

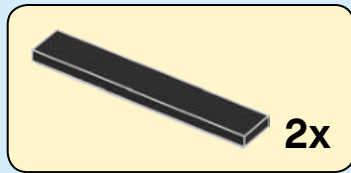
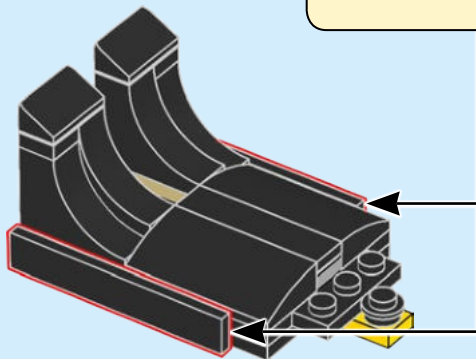

155

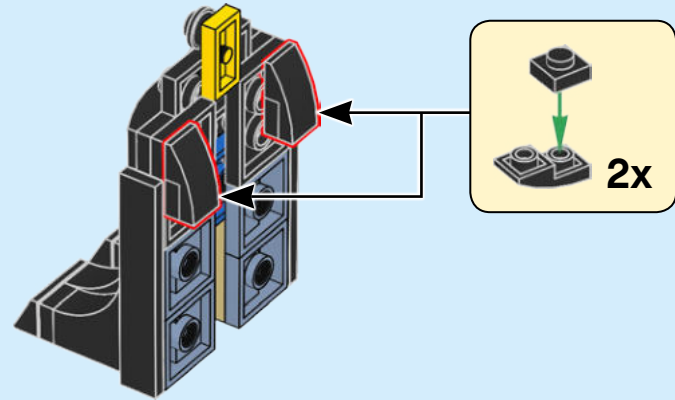
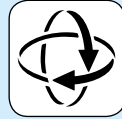

156

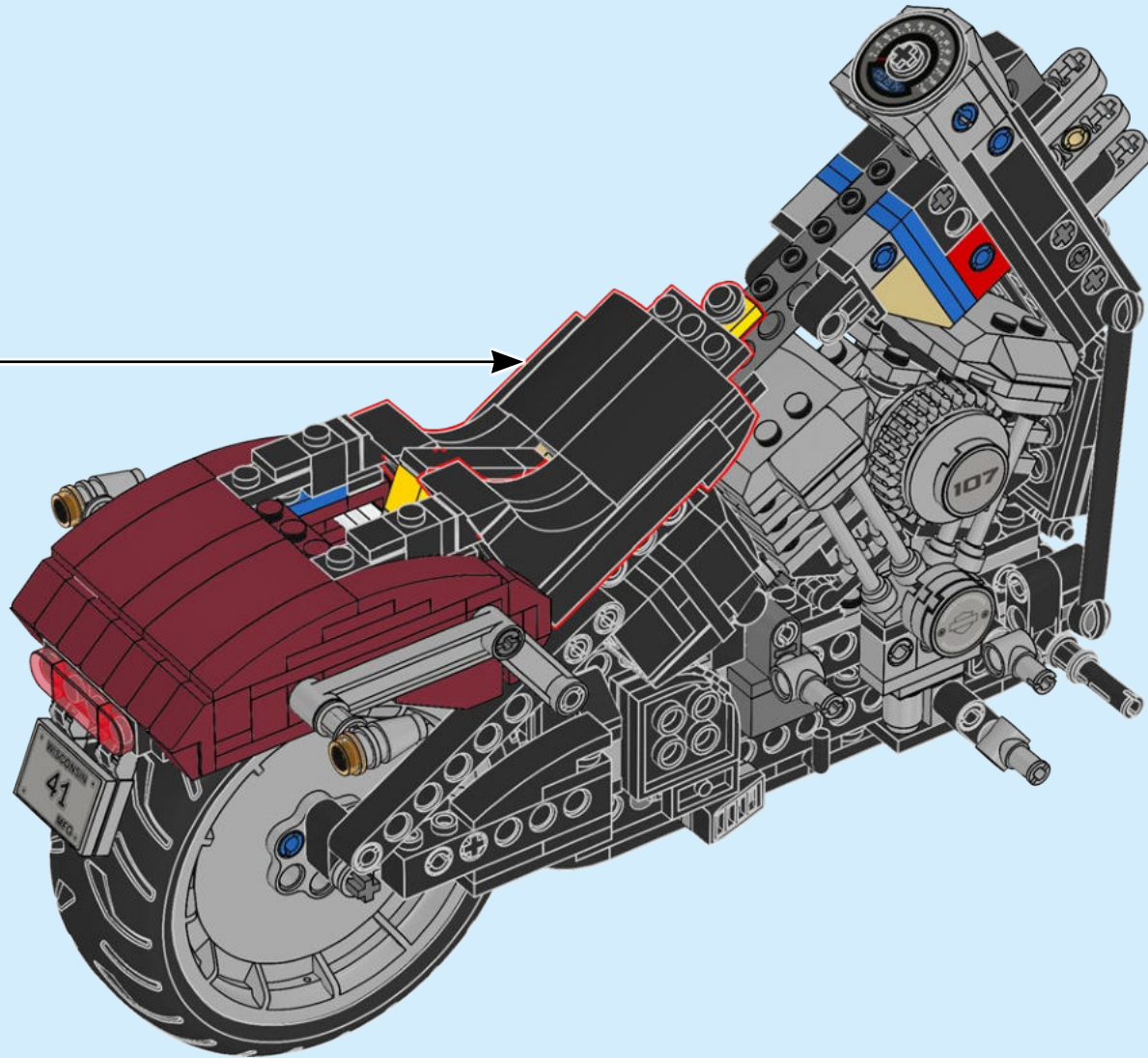

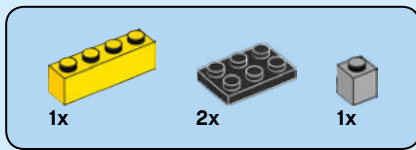

# 157

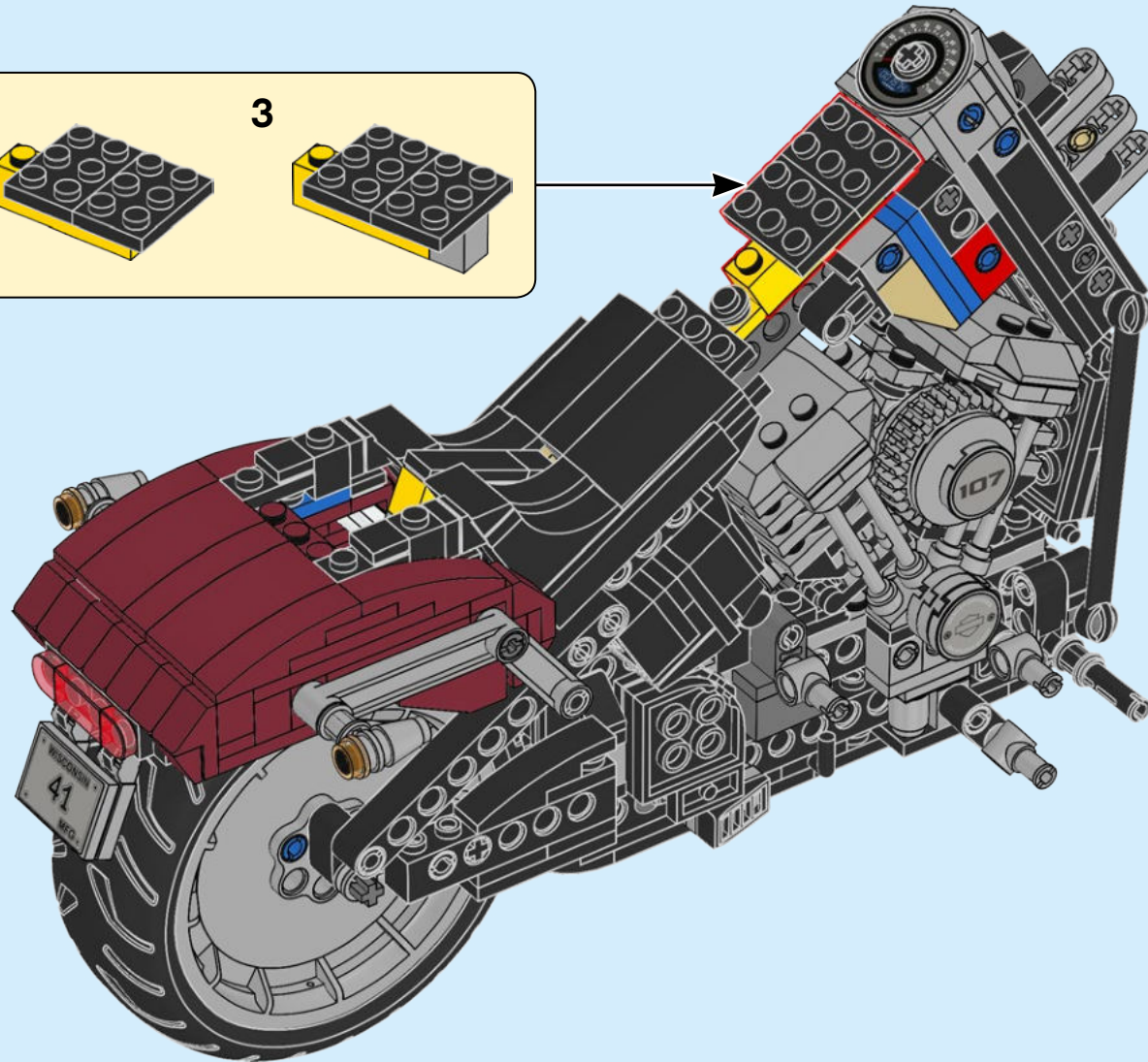
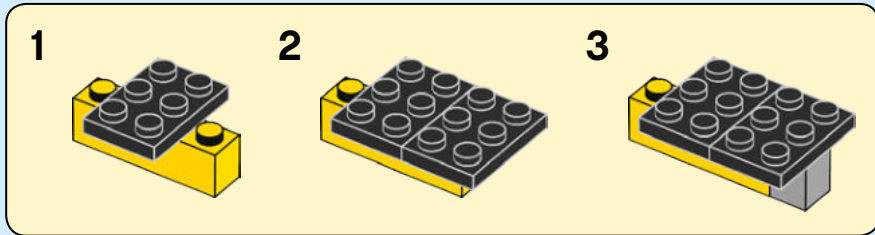



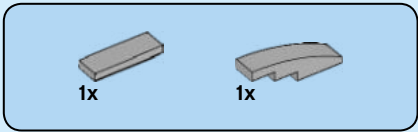

158

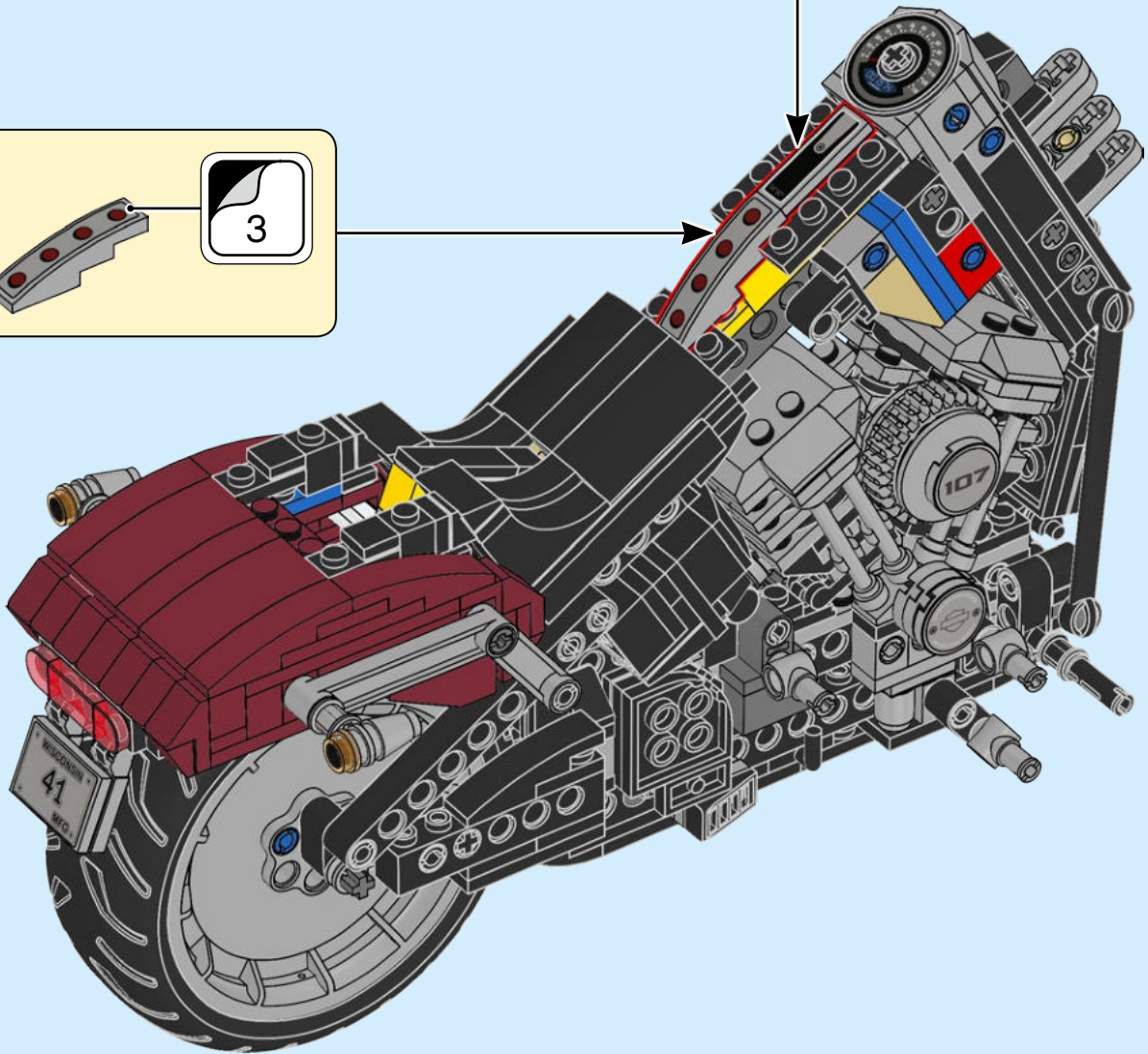
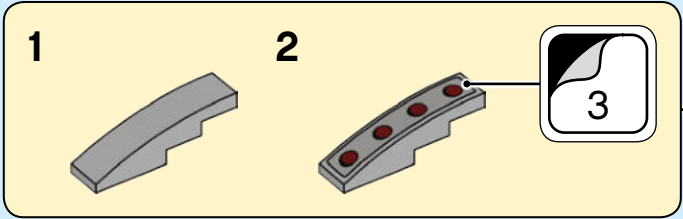
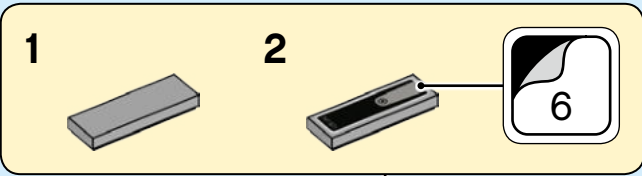

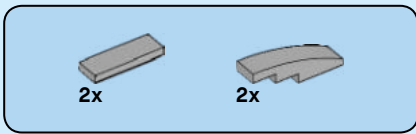

159

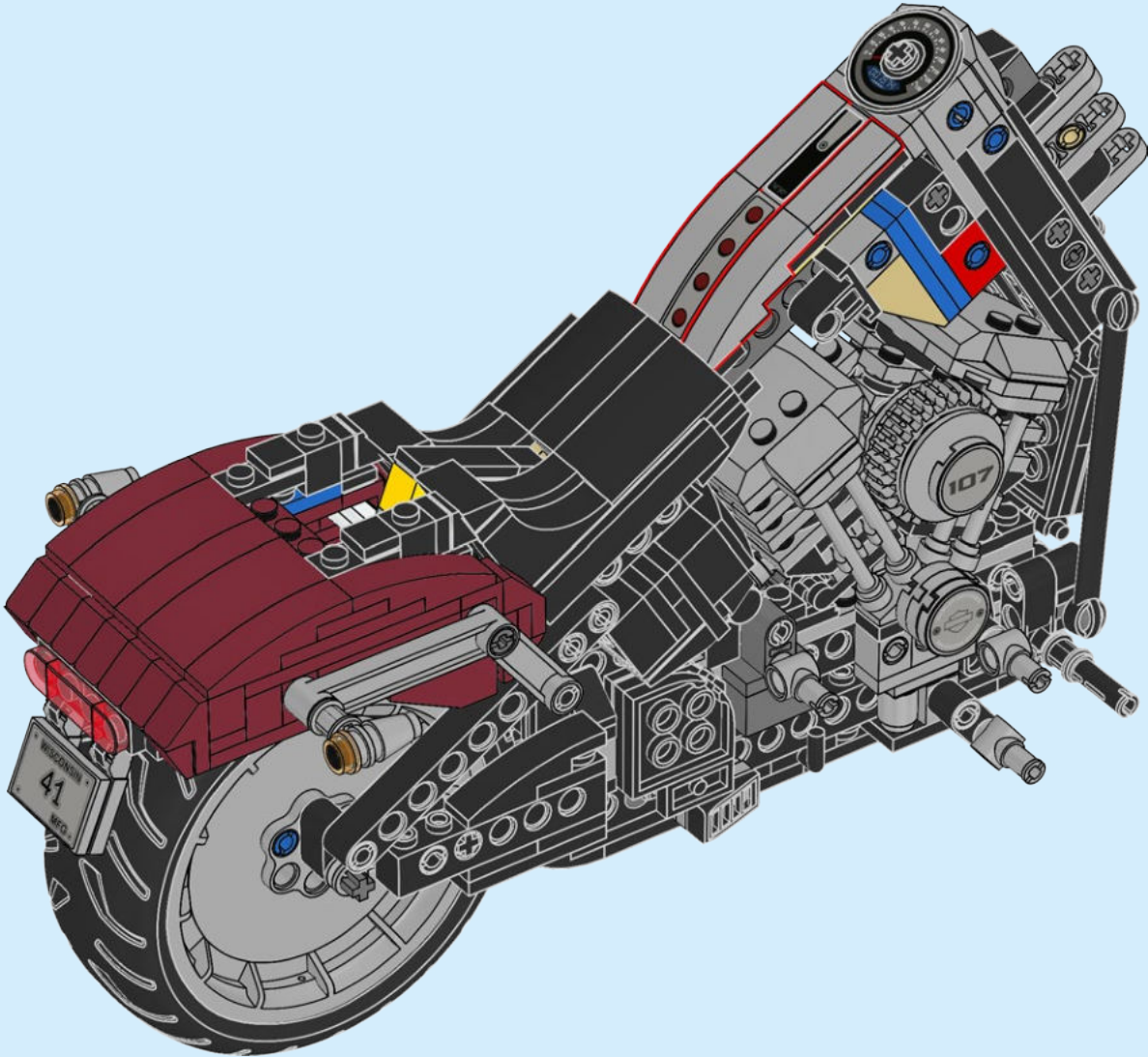



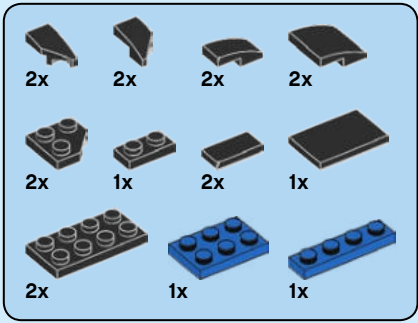

# 160

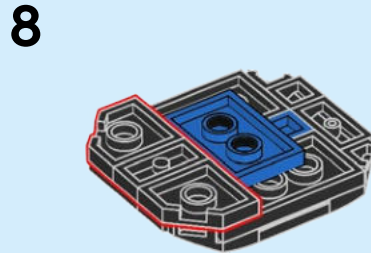
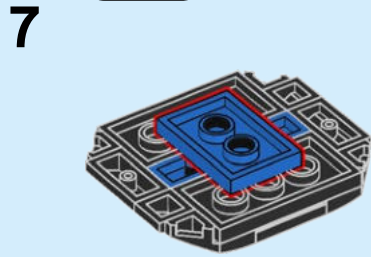
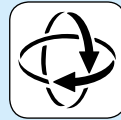
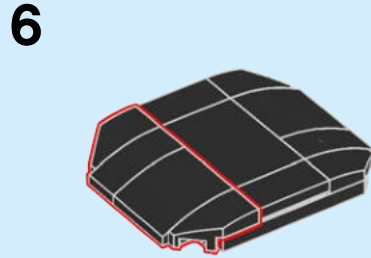
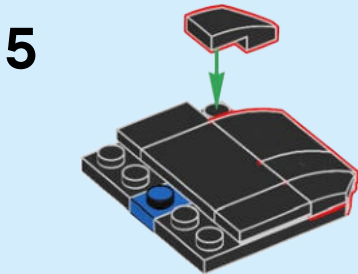
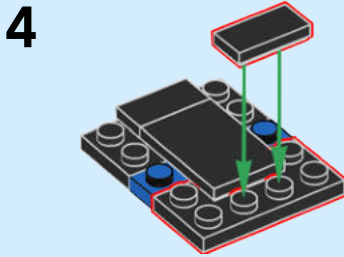
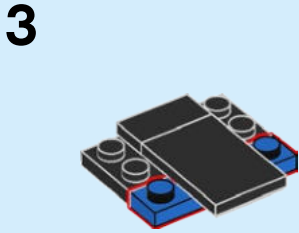
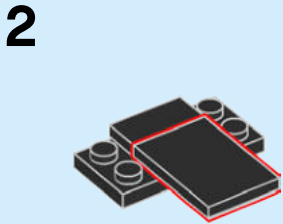
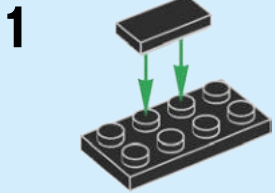

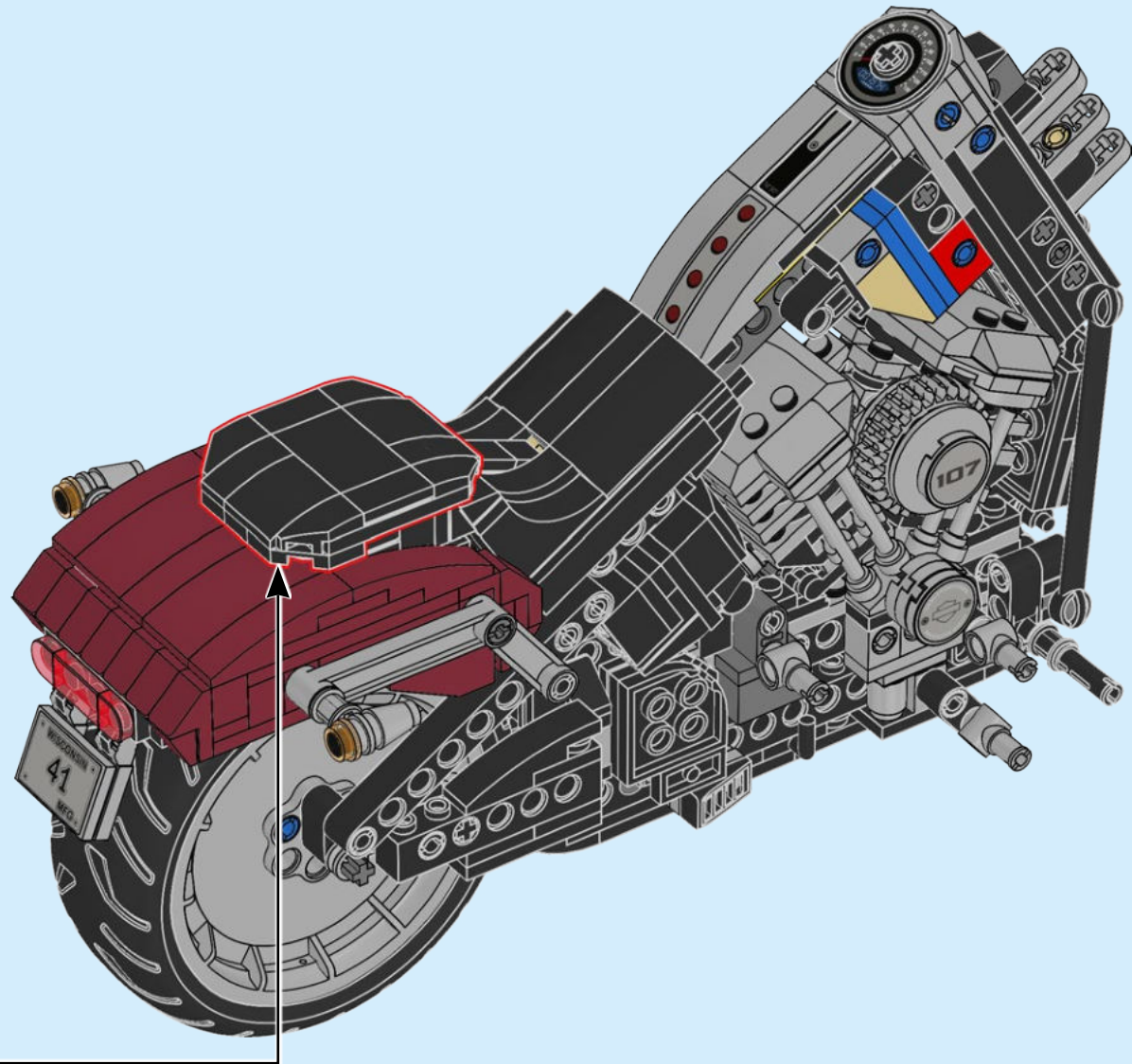

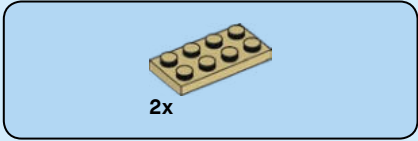

2x

# 161

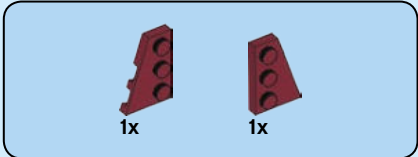
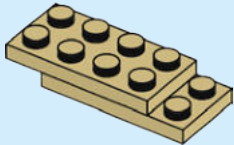

1x

1x

# 162

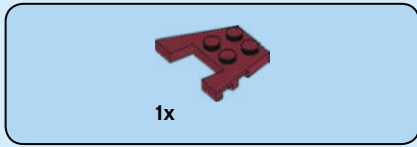
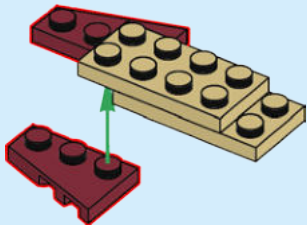

1x

# 163

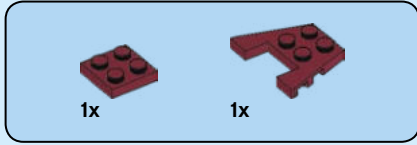
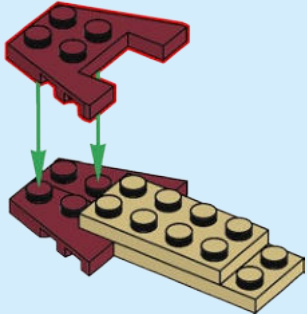

1x

1x

# 164

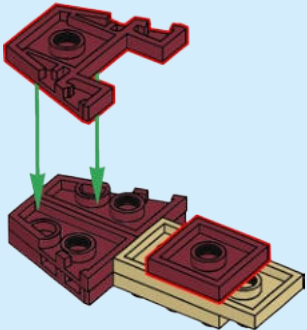

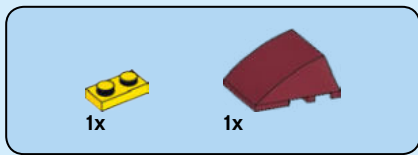

165

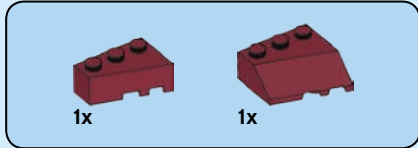
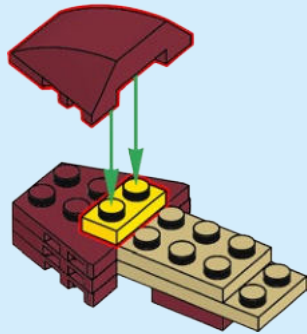

166

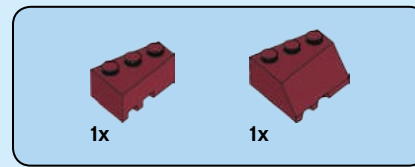
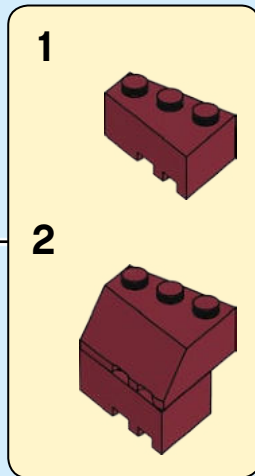
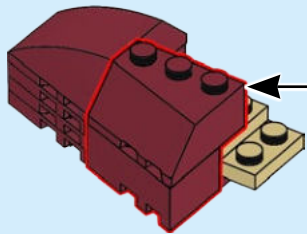

167

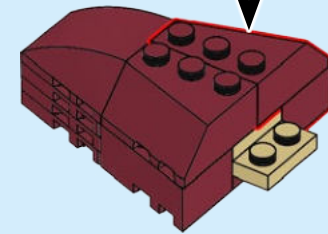
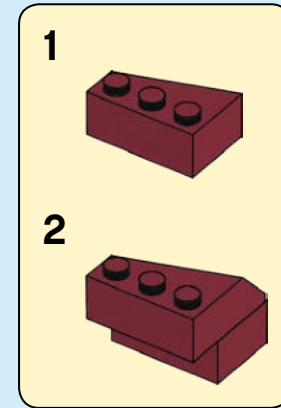

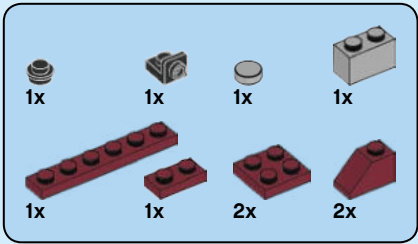

# 168

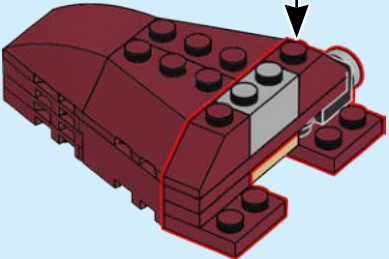
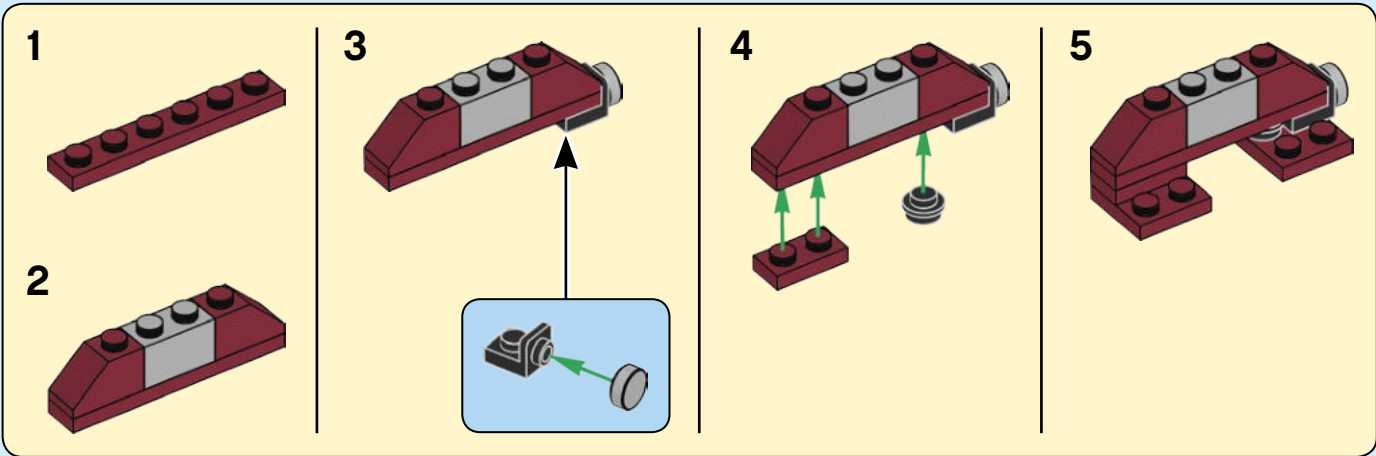



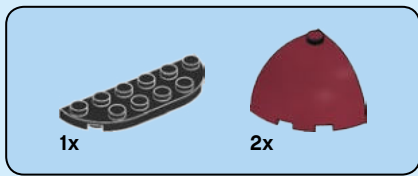

169

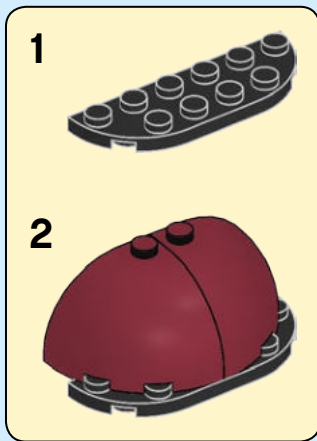
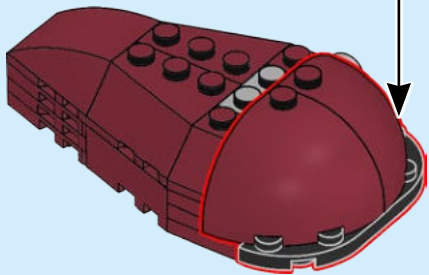

170

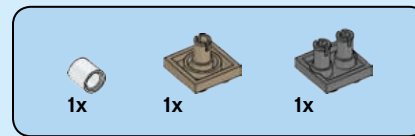
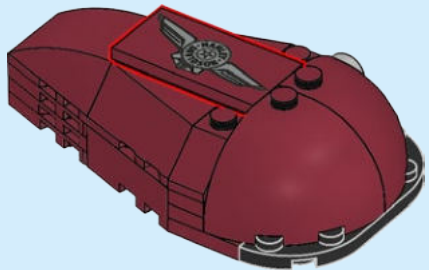

171

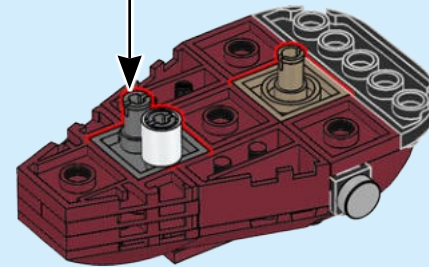
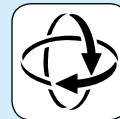
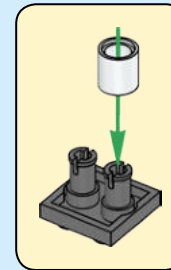

172

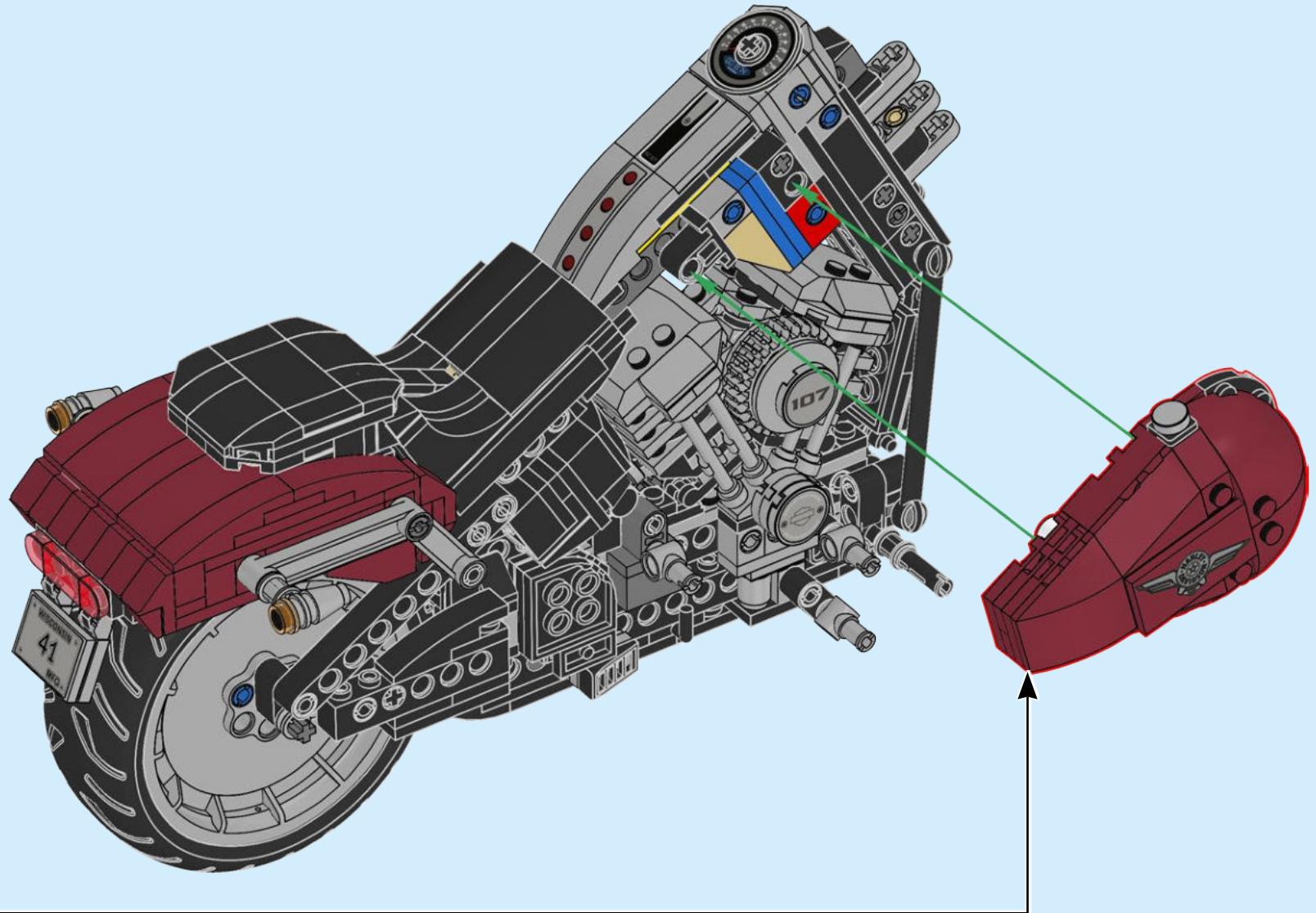

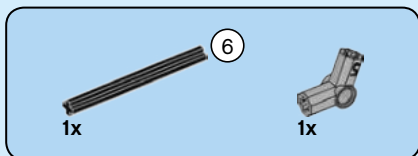
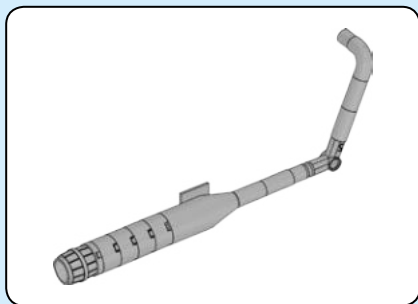

173

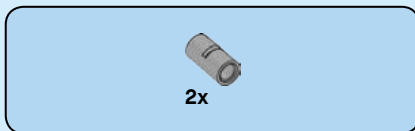
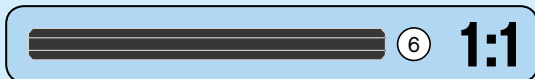
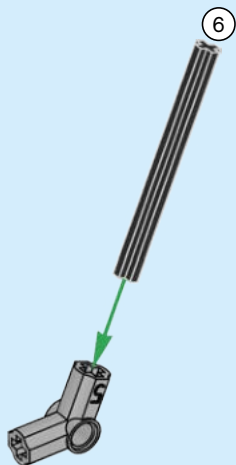

174

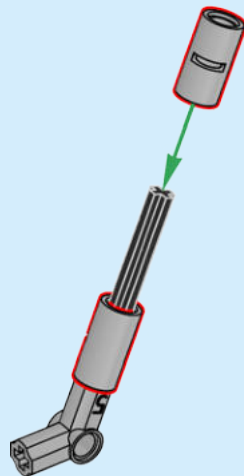

175

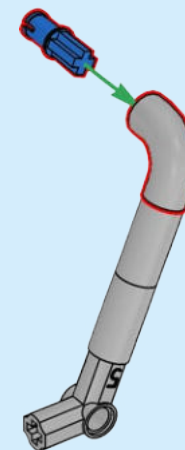



1x

# 176

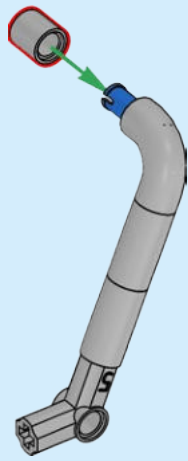

1x

# 178

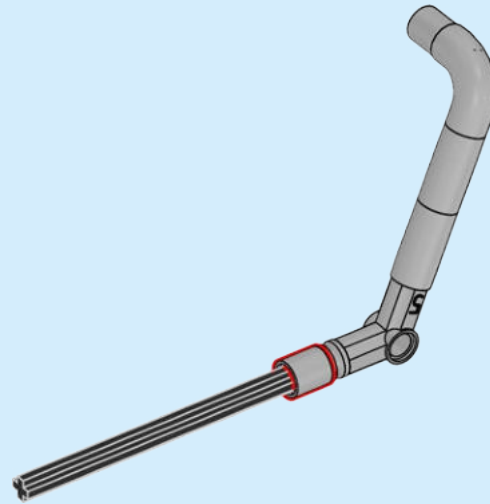

10

1x

1x

# 177

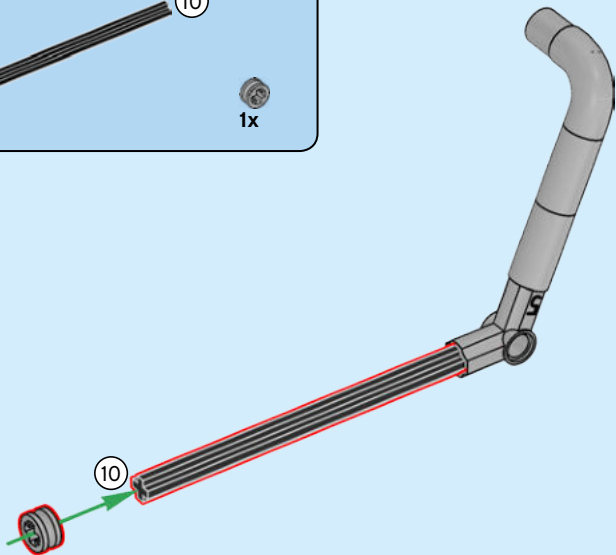

10

10

1:1

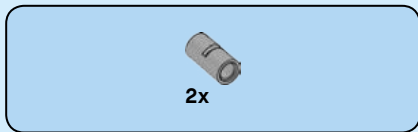

179

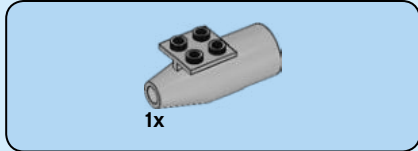
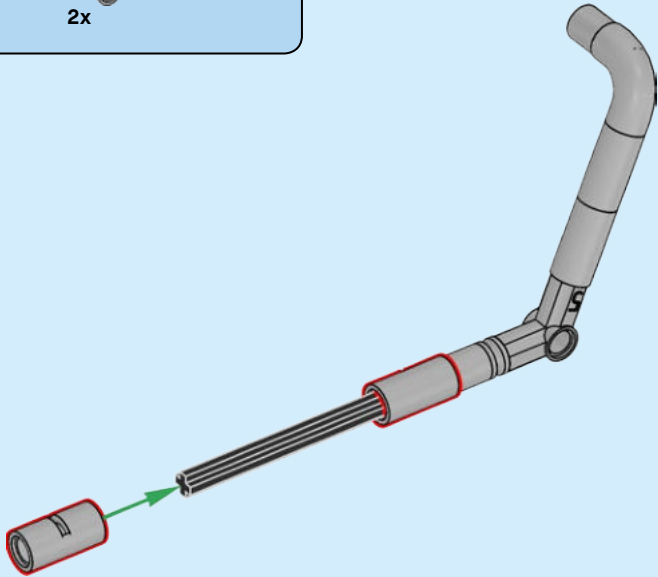

180

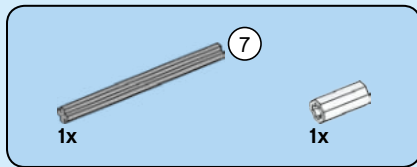
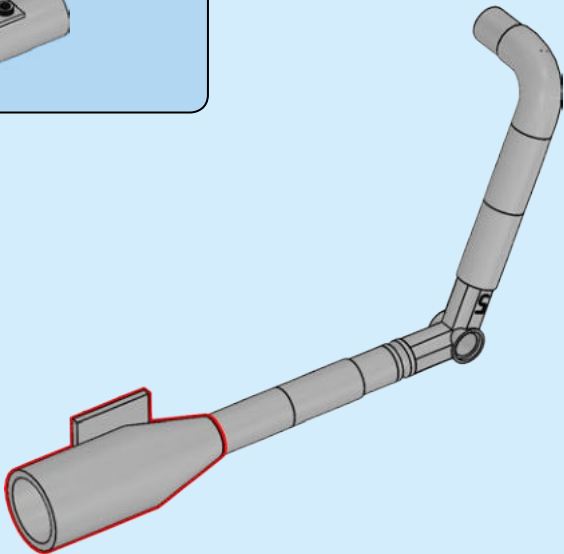

181

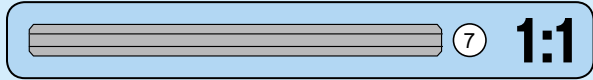
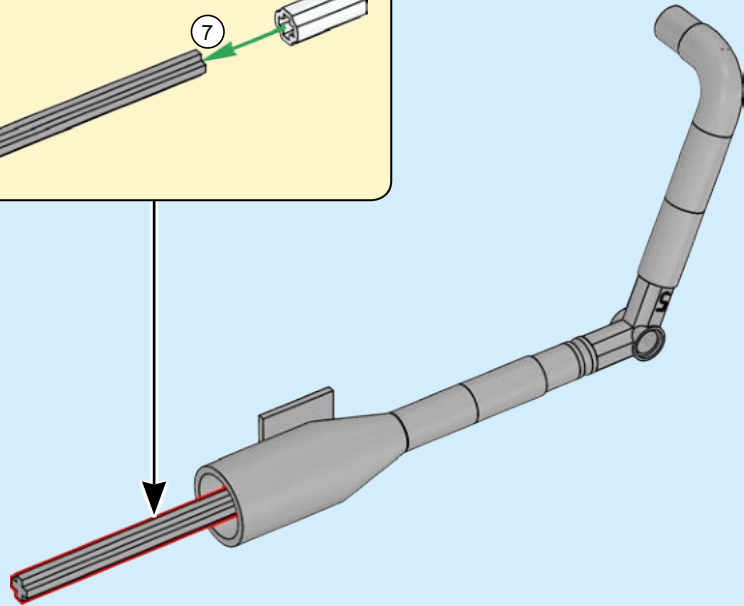
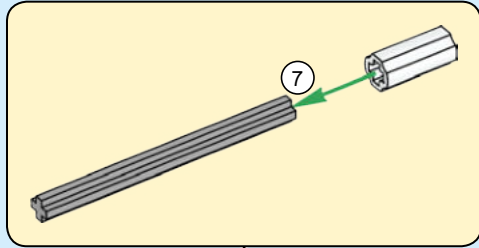





2x

182

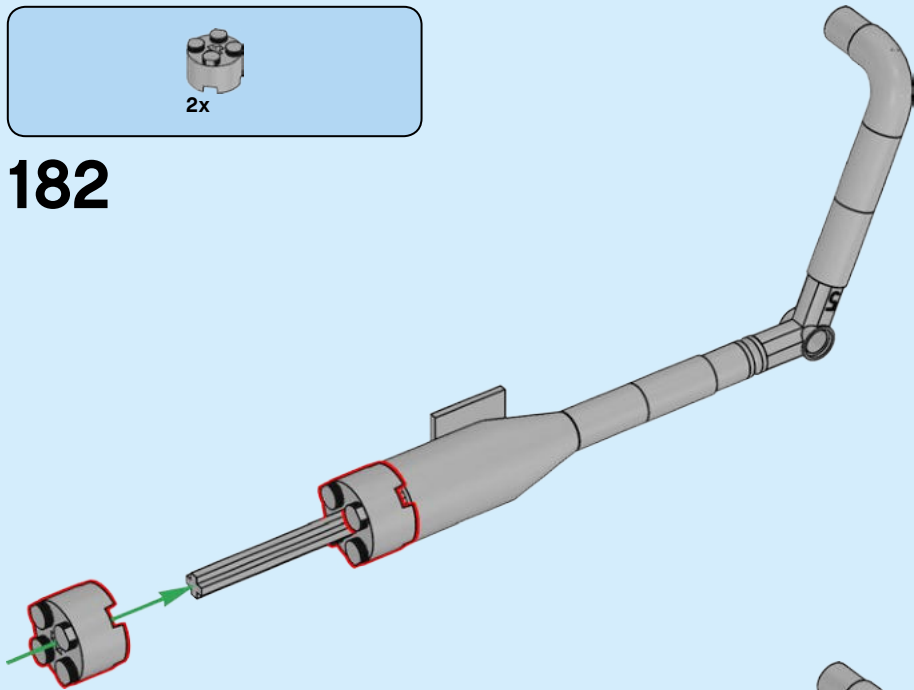

2x

183

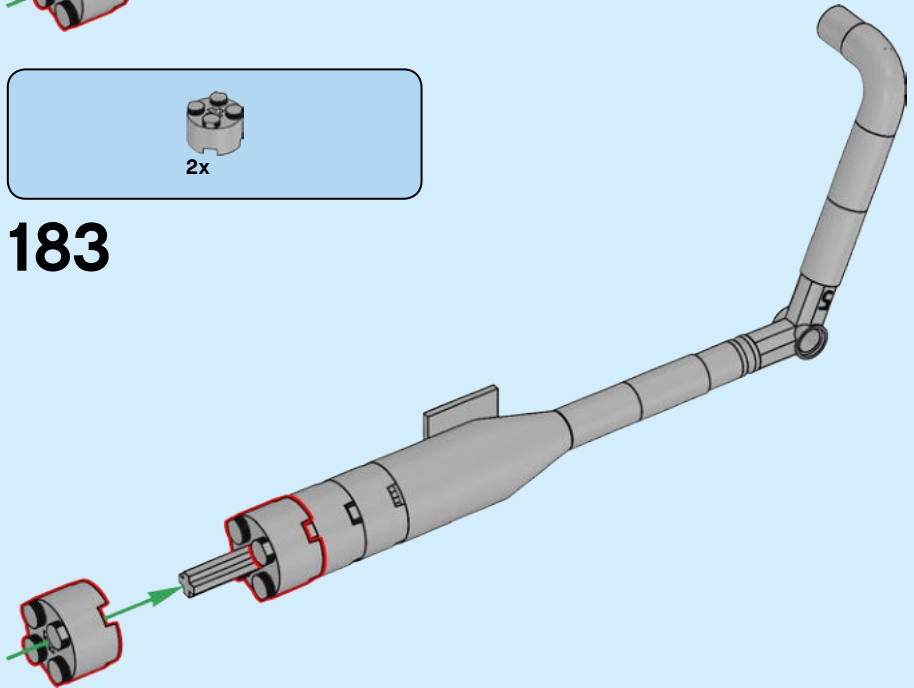

1x

184

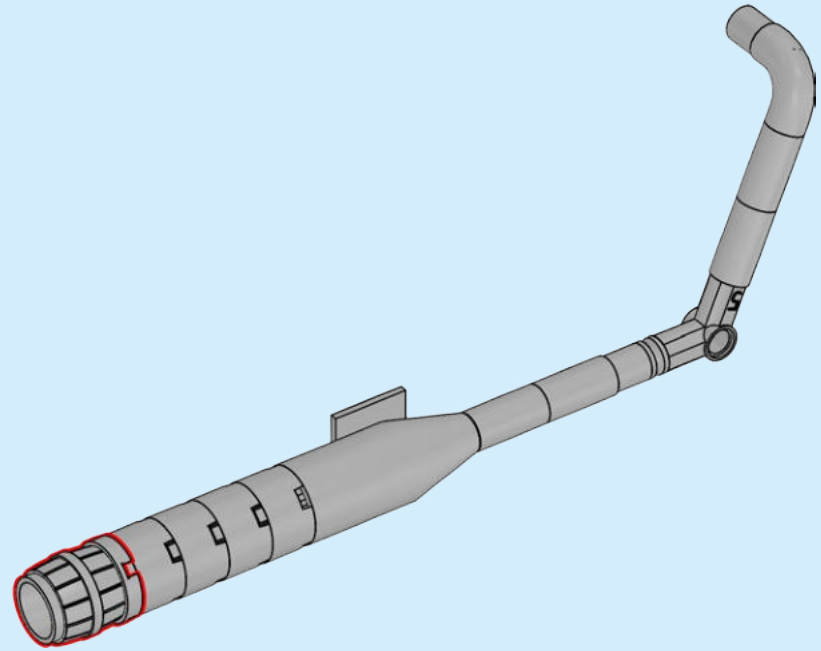

185

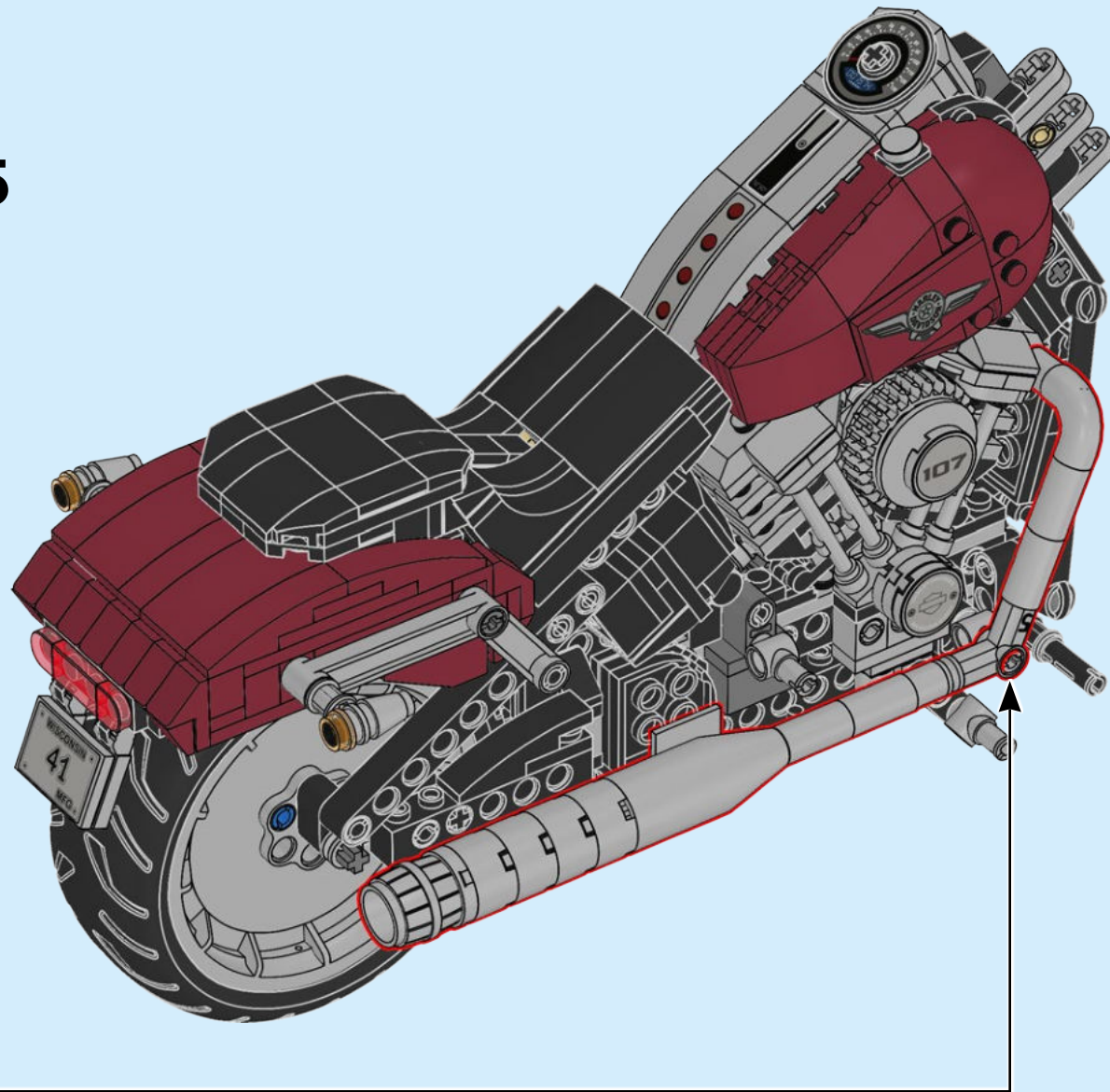

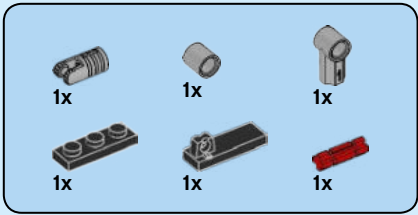

186

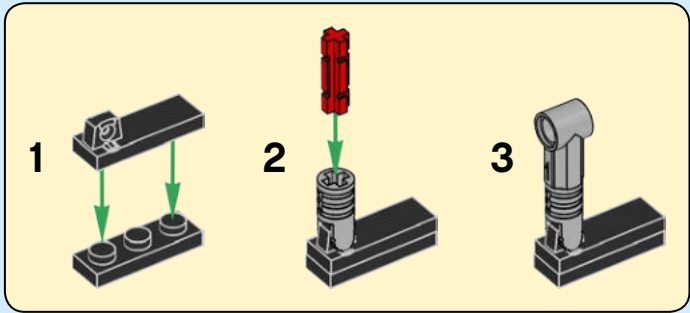
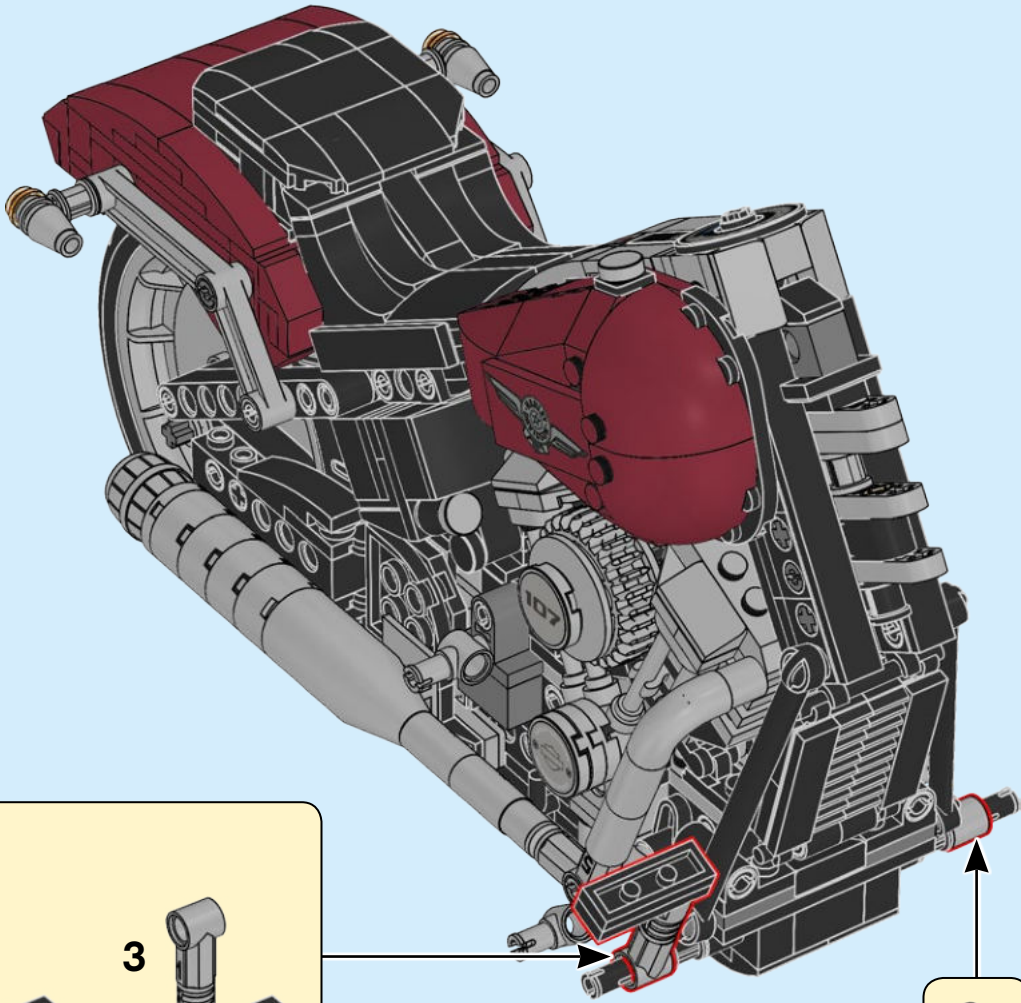

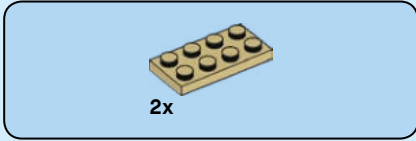

2x

187

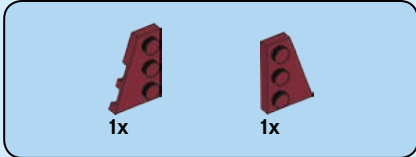
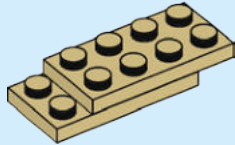

1x

1x

188

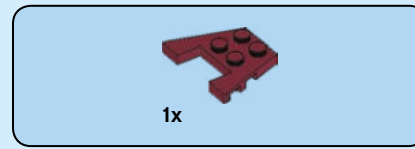
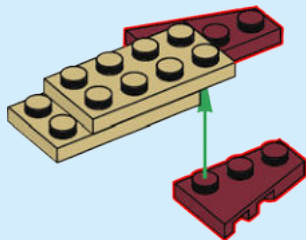

1x

189

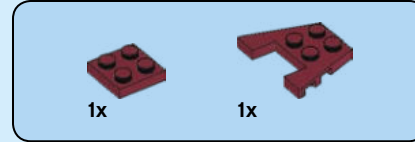
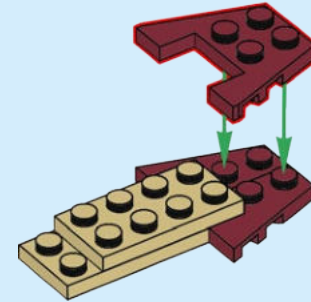

1x

1x

190

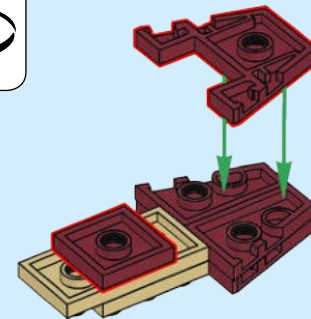
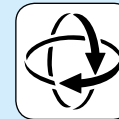

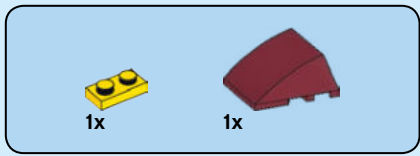

191

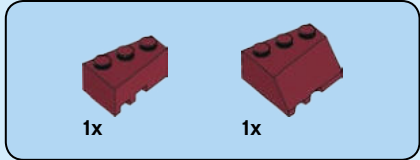
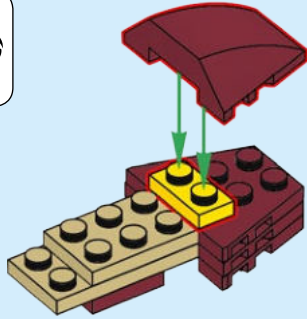

192

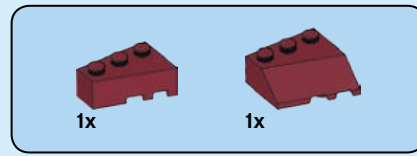
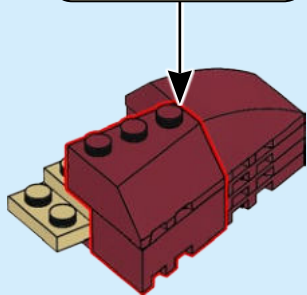
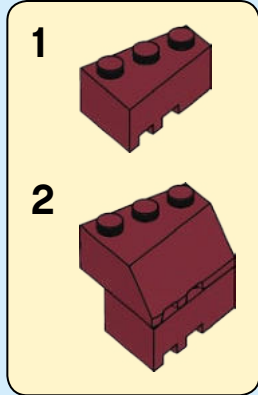

193

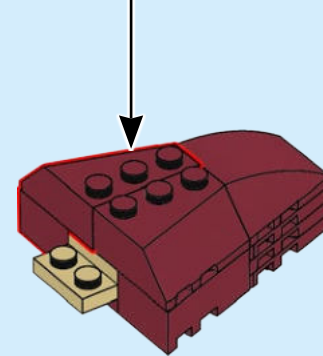
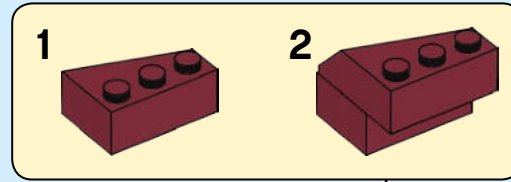



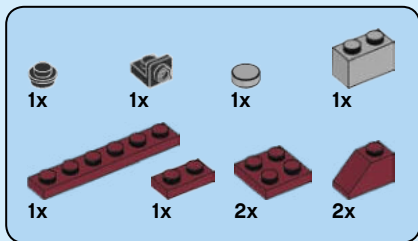

194

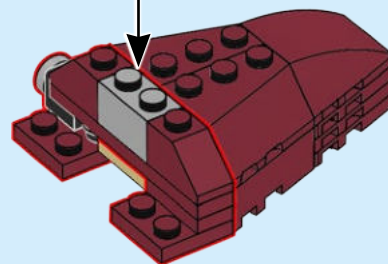
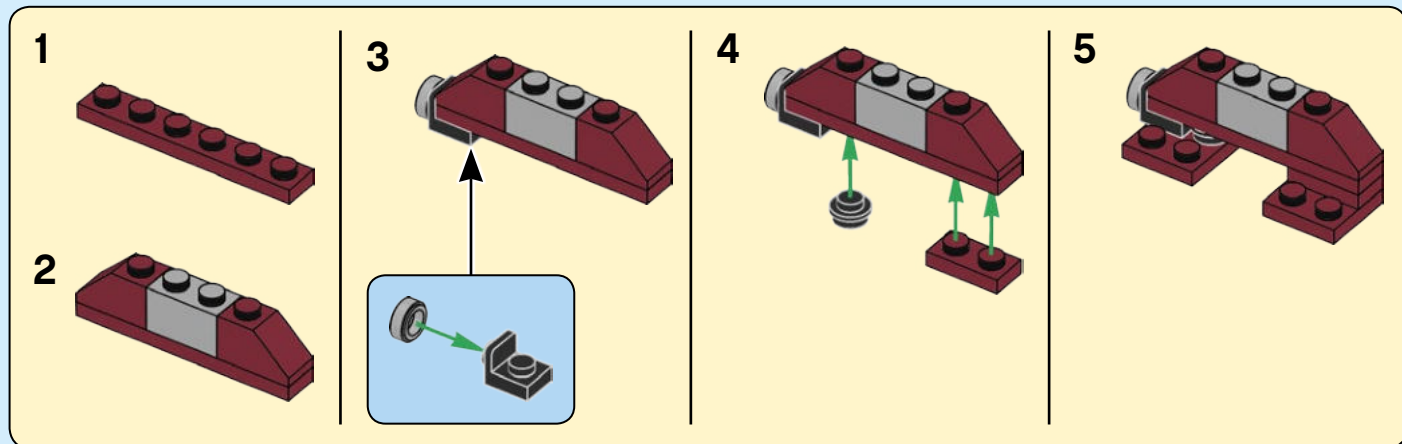

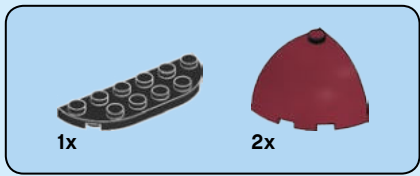

195

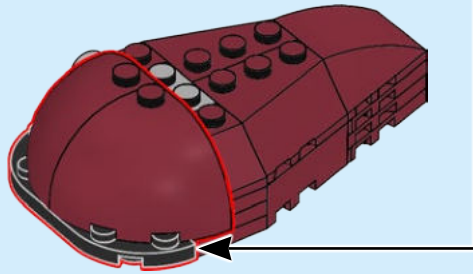
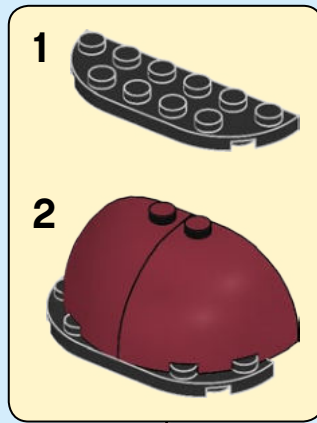

196

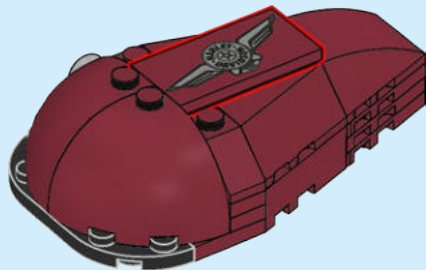

197

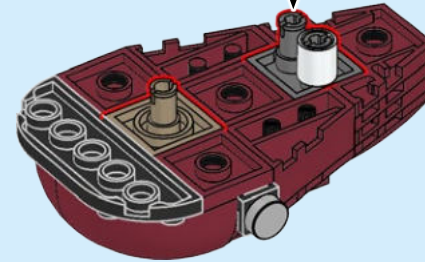
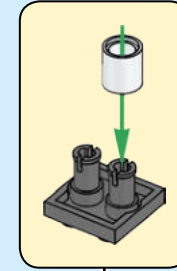
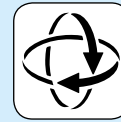

198

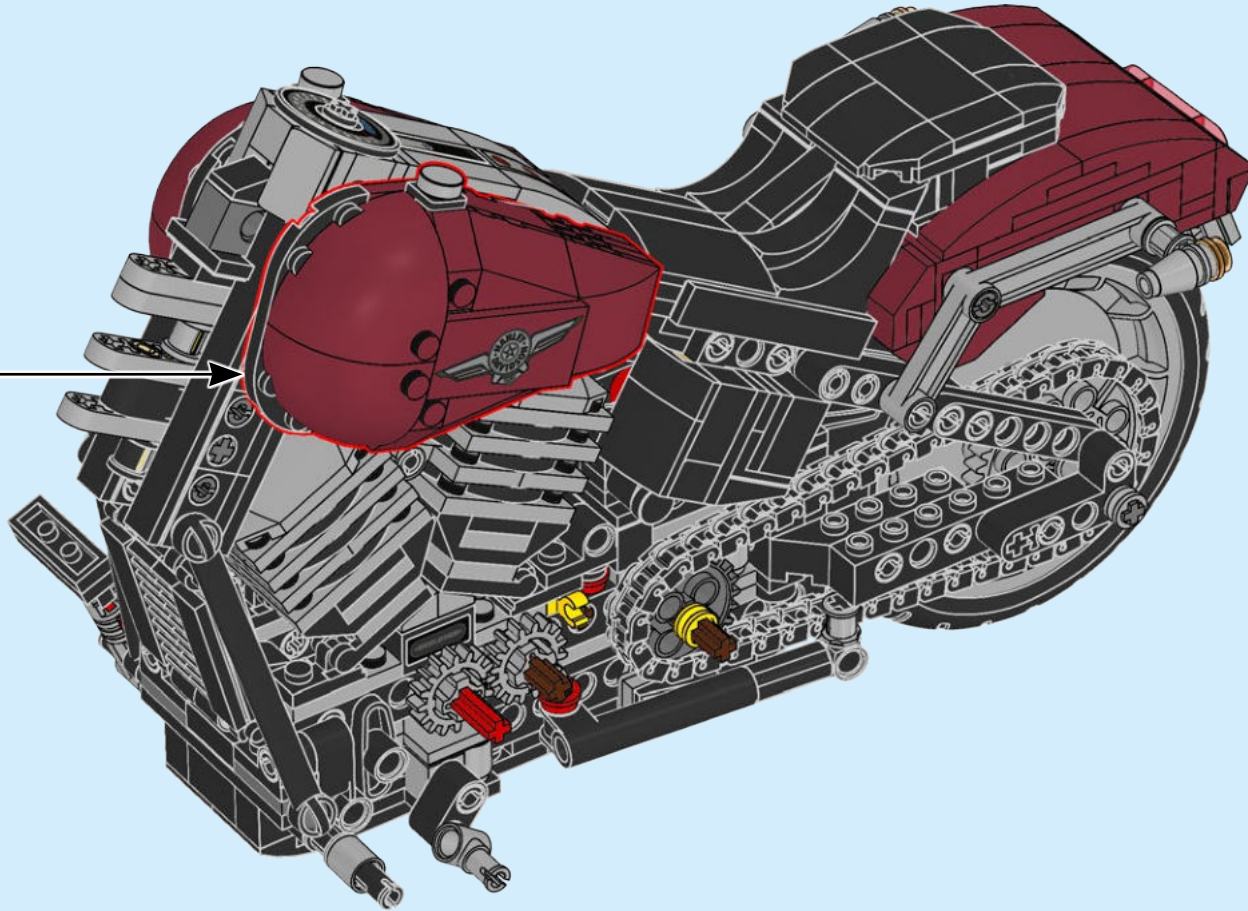

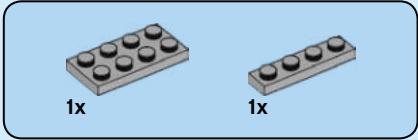
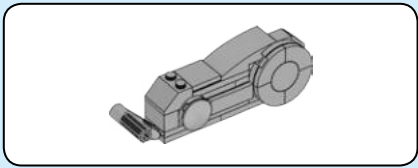

199

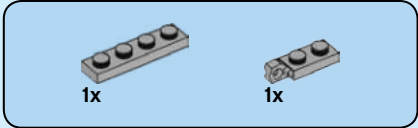
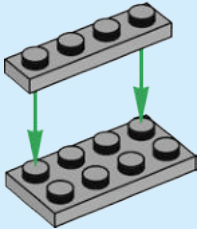

200

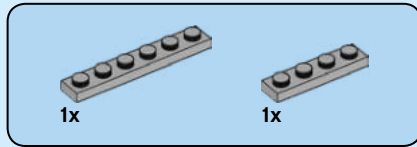
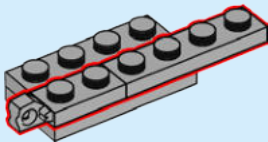

201

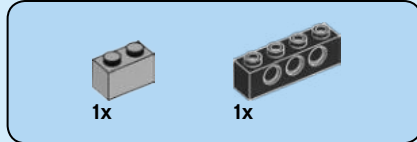
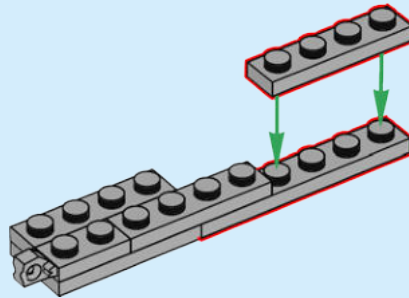

202

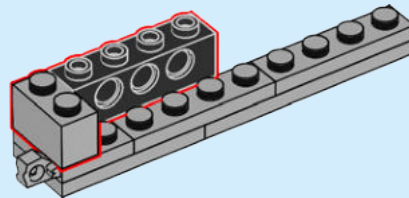

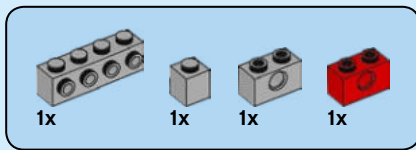

# 203

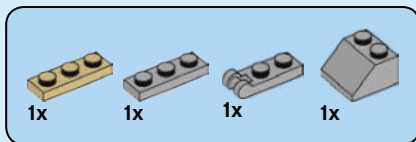
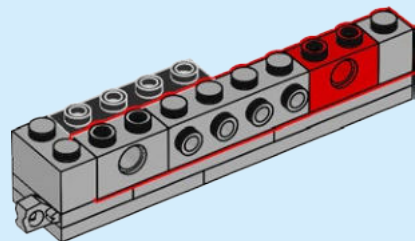

# 204

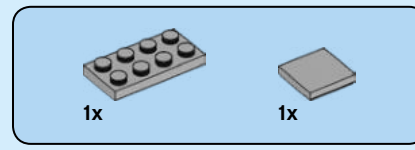
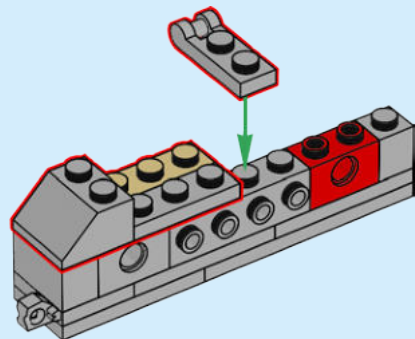

# 205

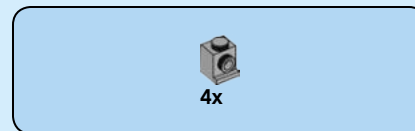
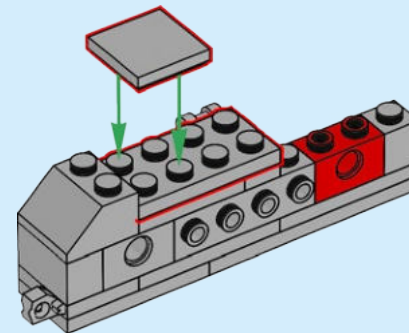

# 206

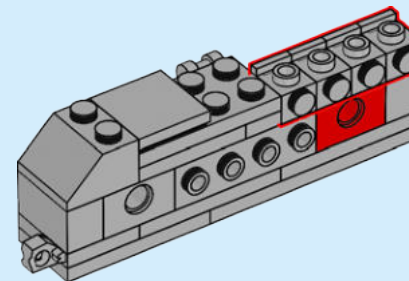



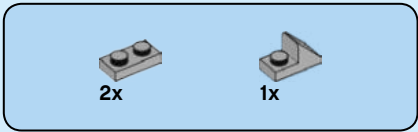

207

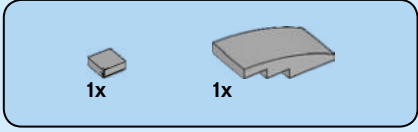
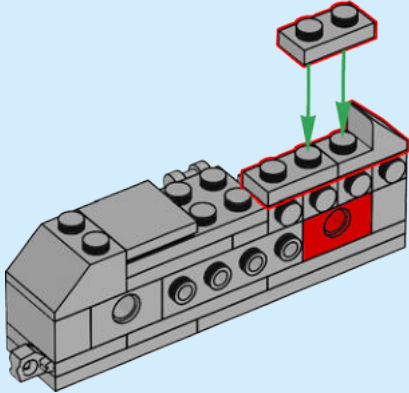

208

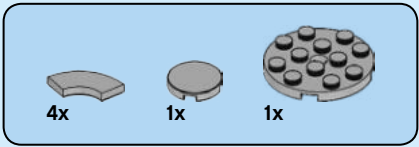
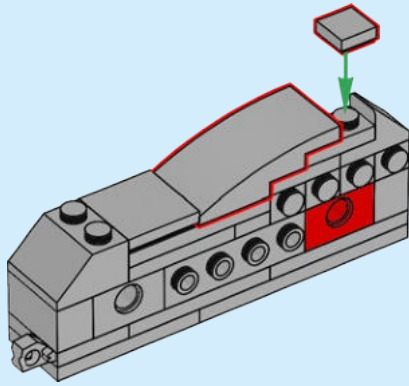

209

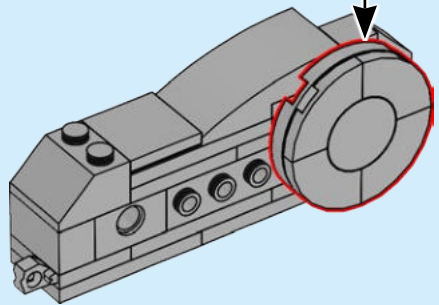
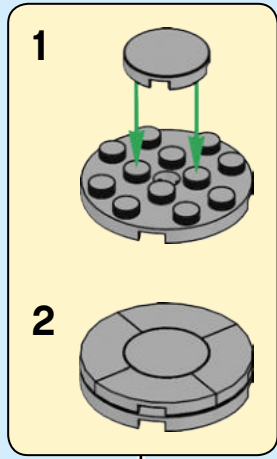

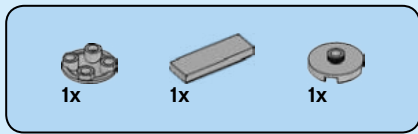

210

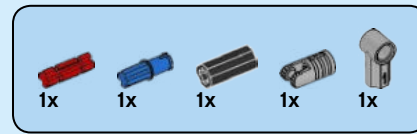
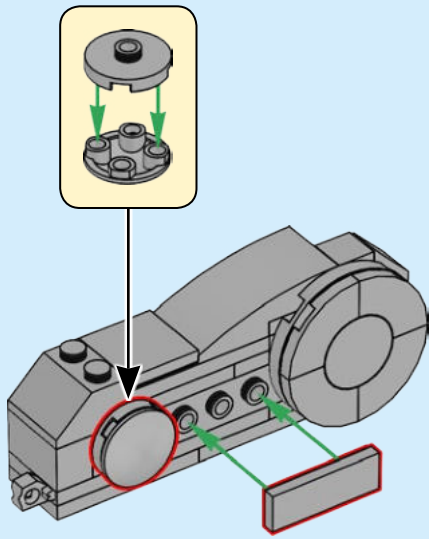

211

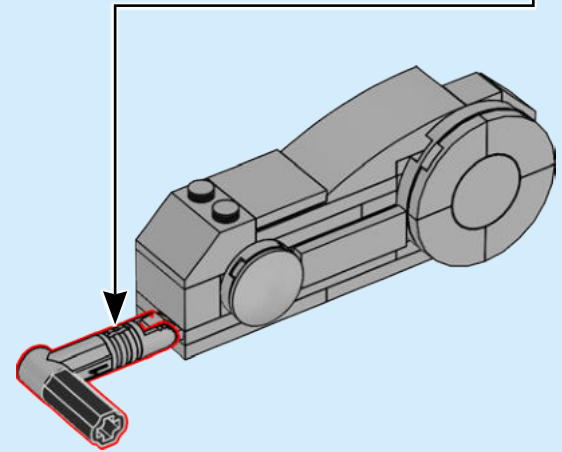
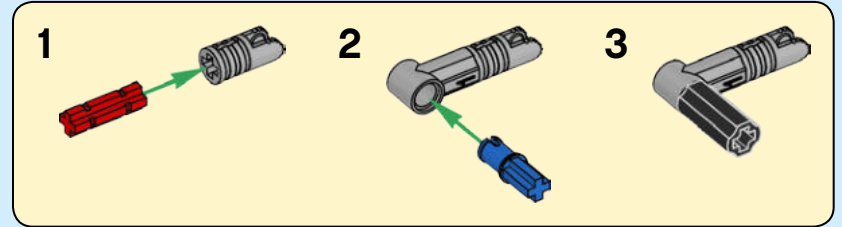

212

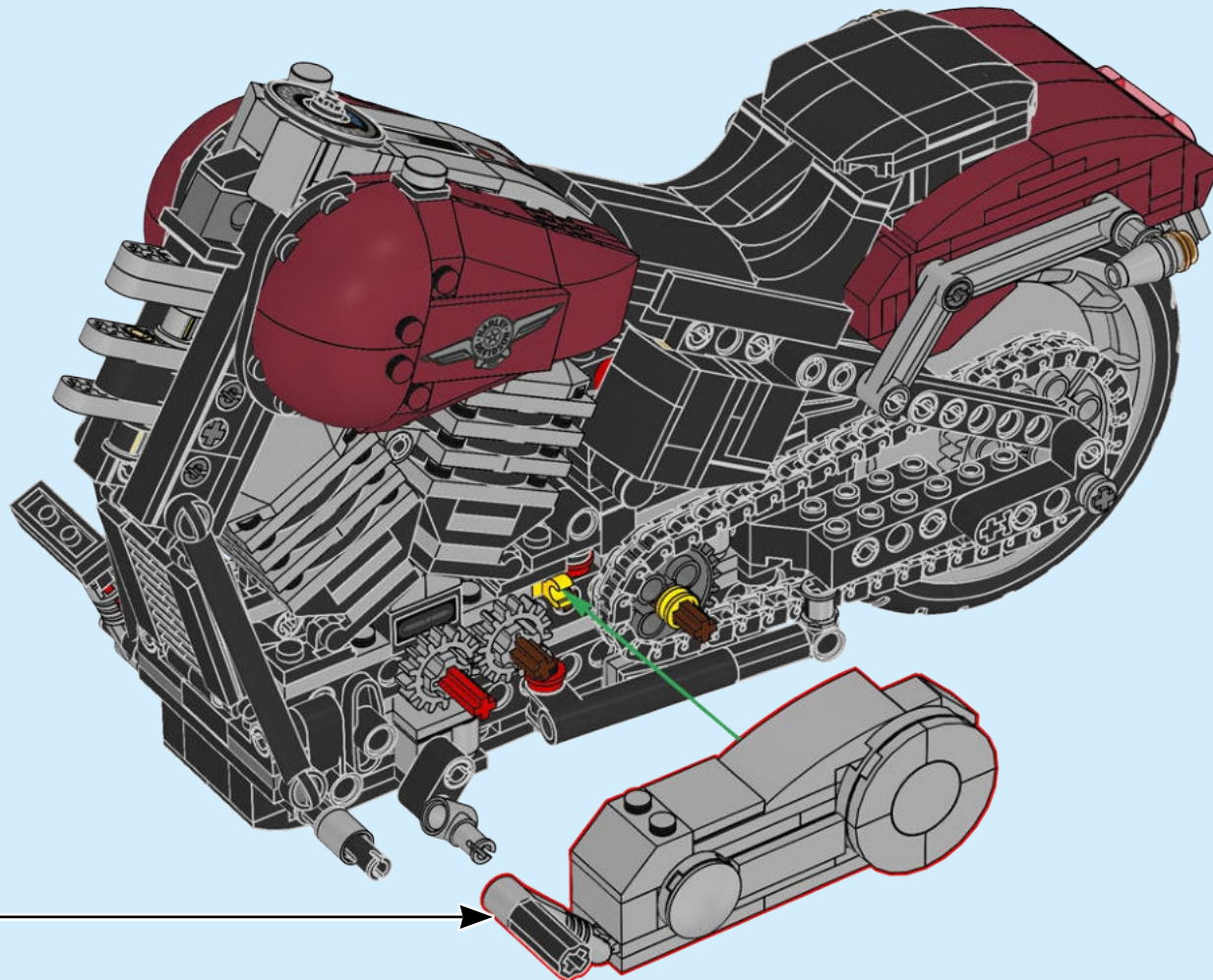

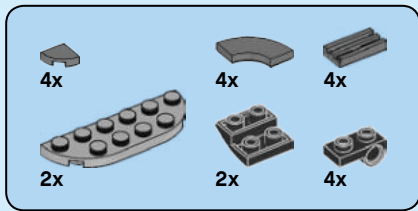

213

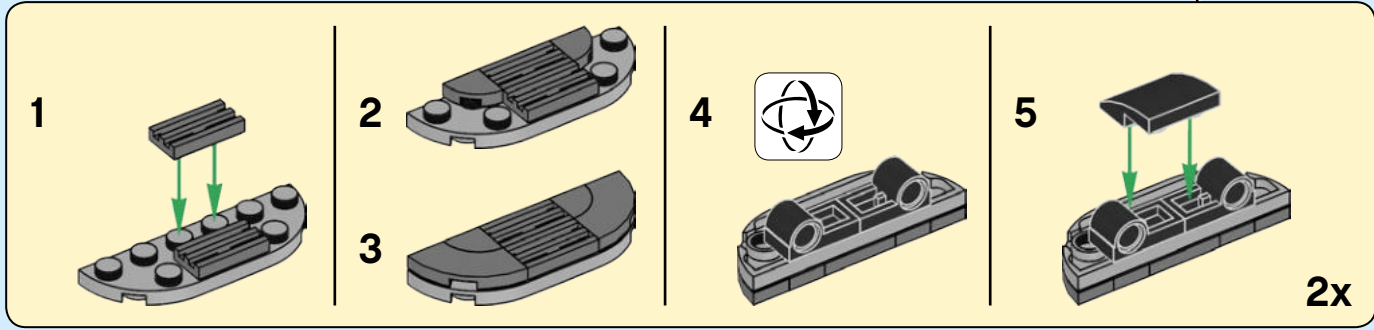
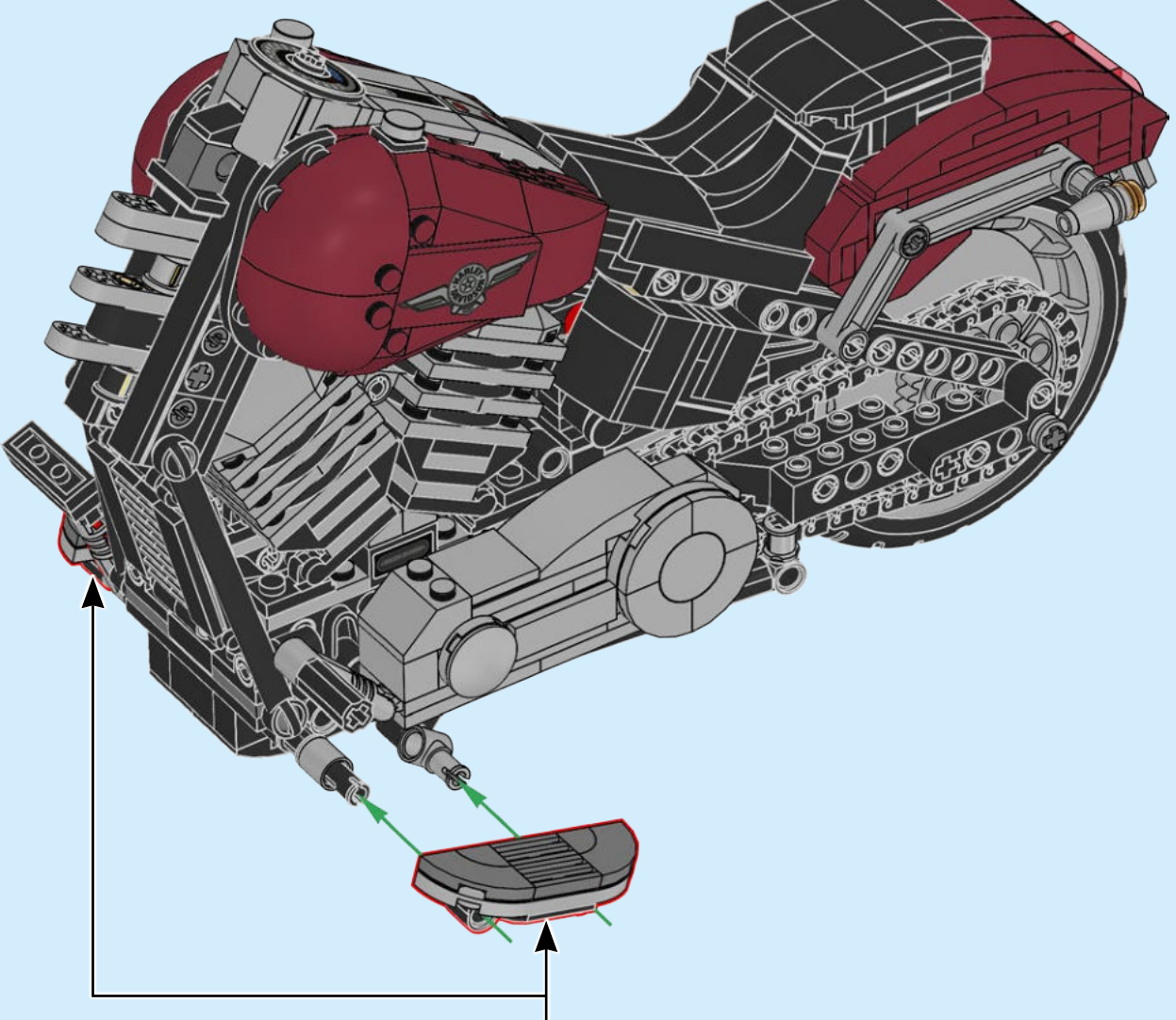



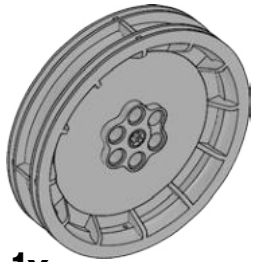

1x



1x

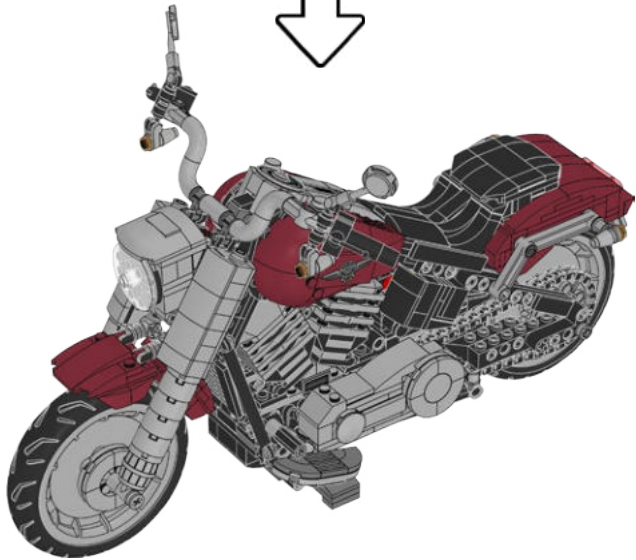
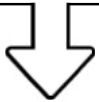
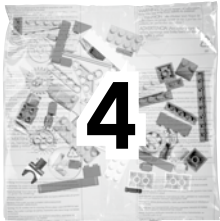

2x

1x

# 214

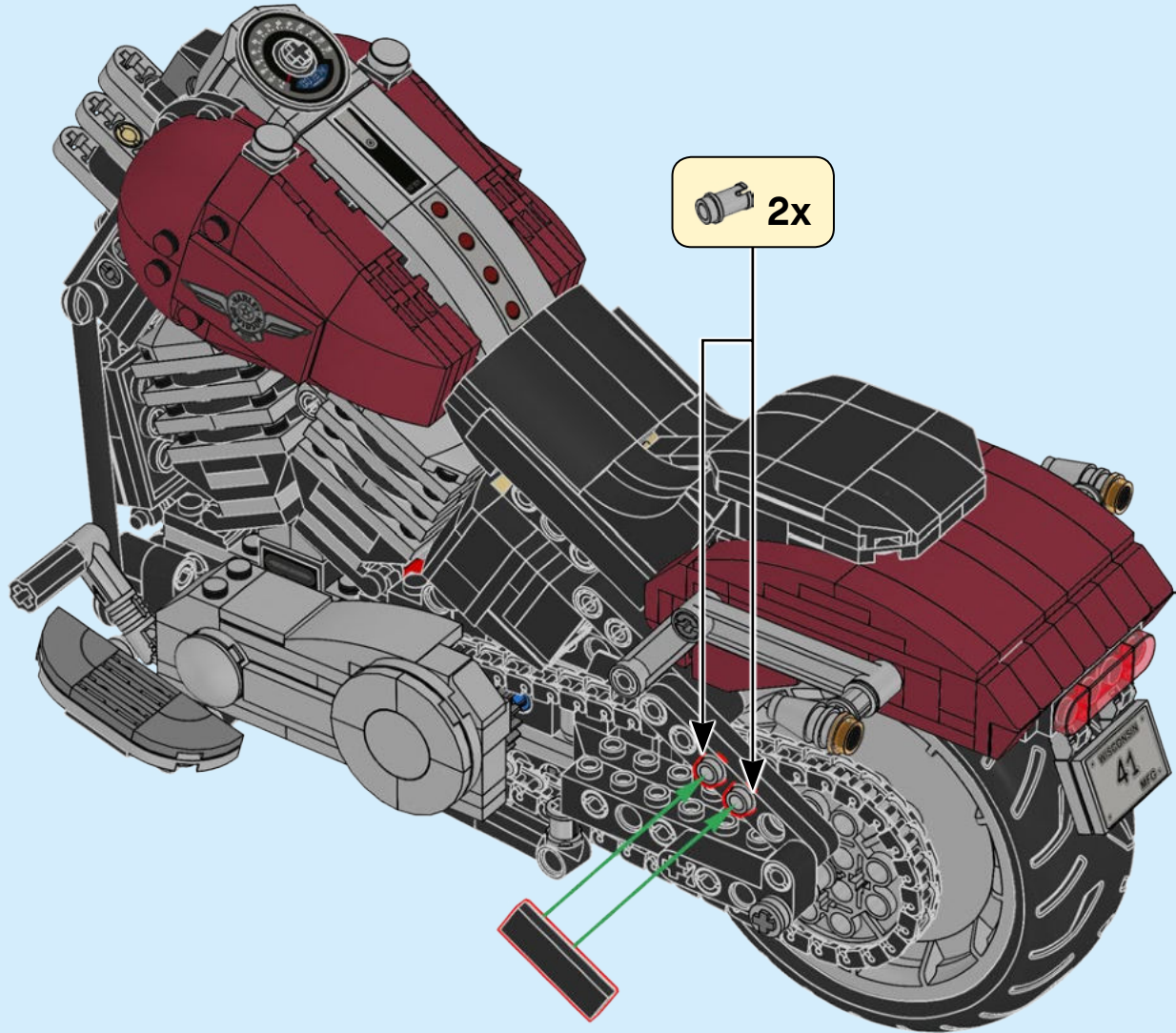

2x



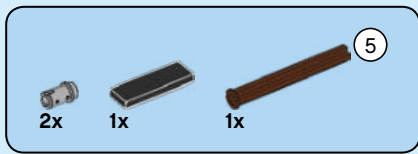

215

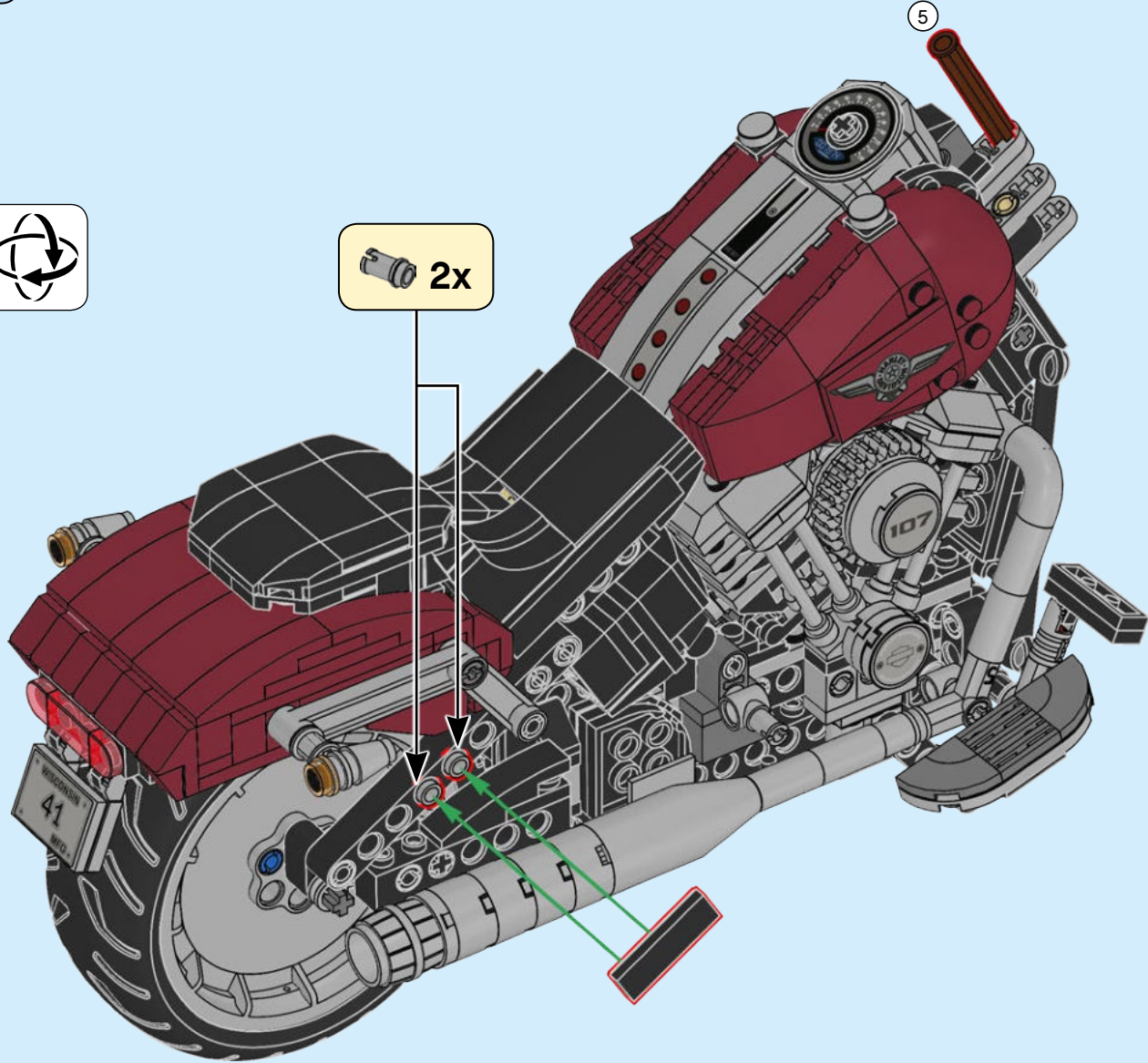
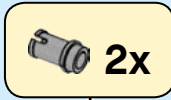

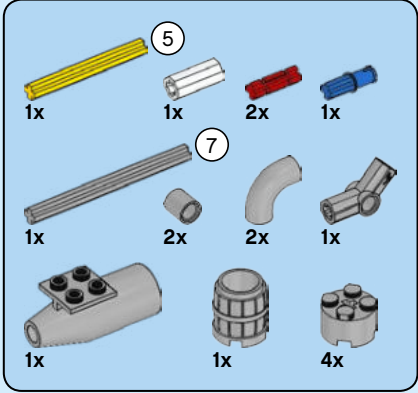
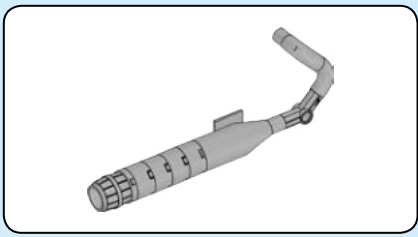

# 216

1

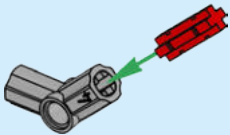

2

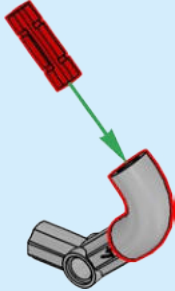

3

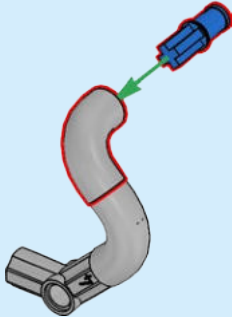

4

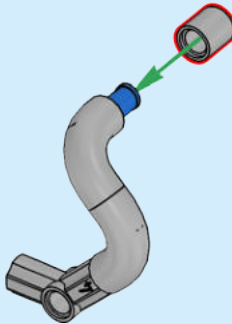

5

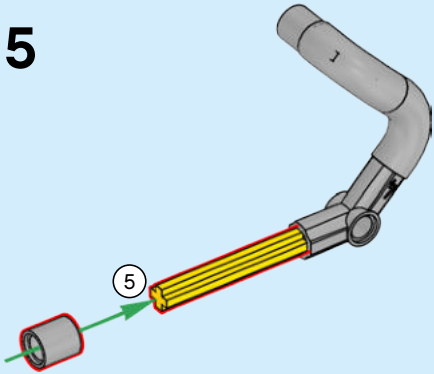

6

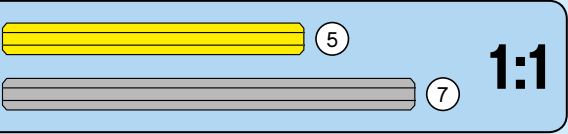
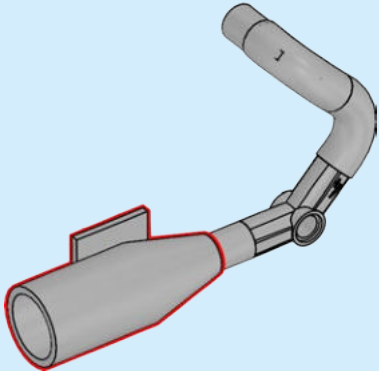

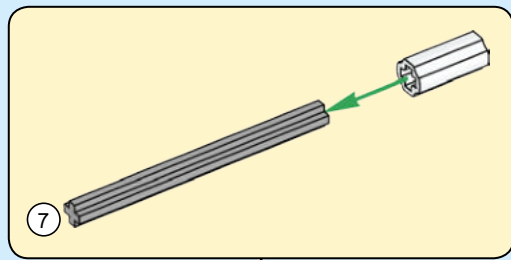

7

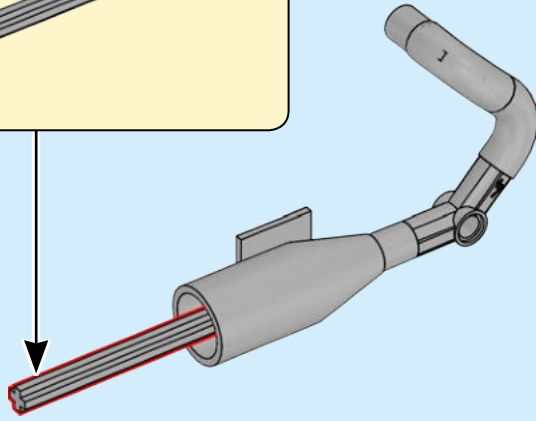

8

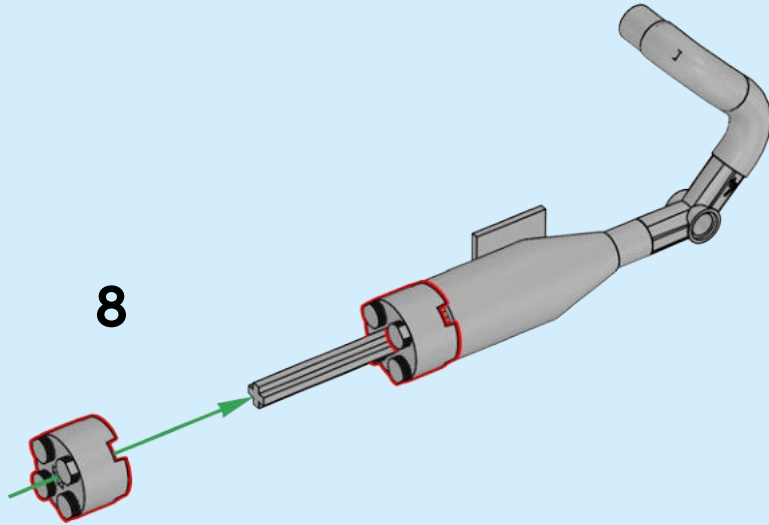

9

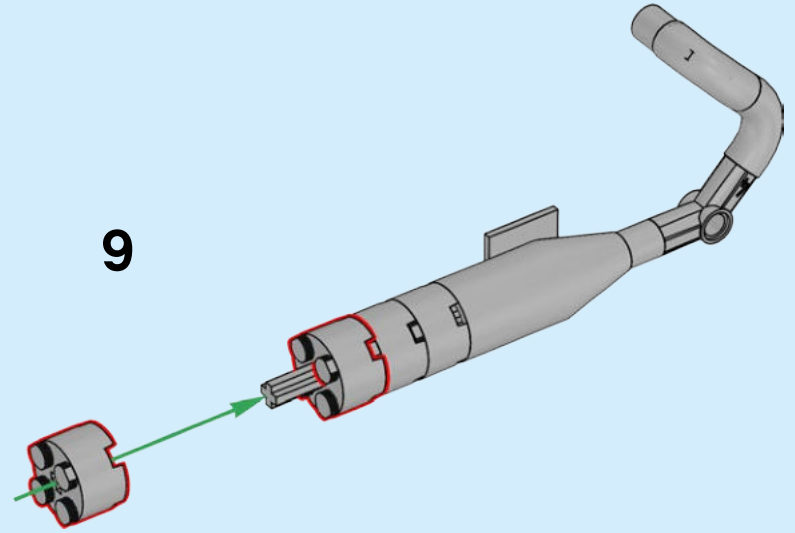

10

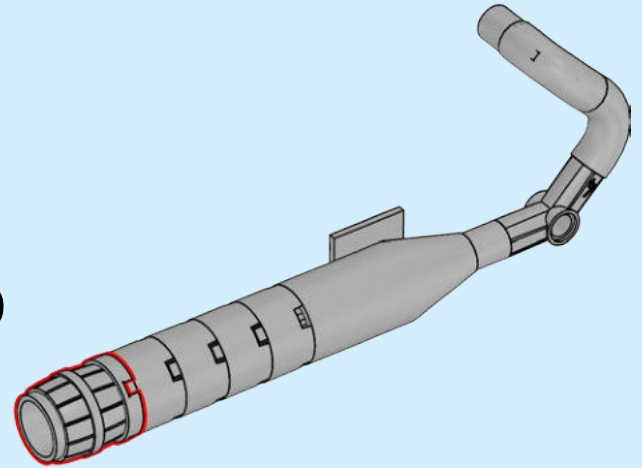

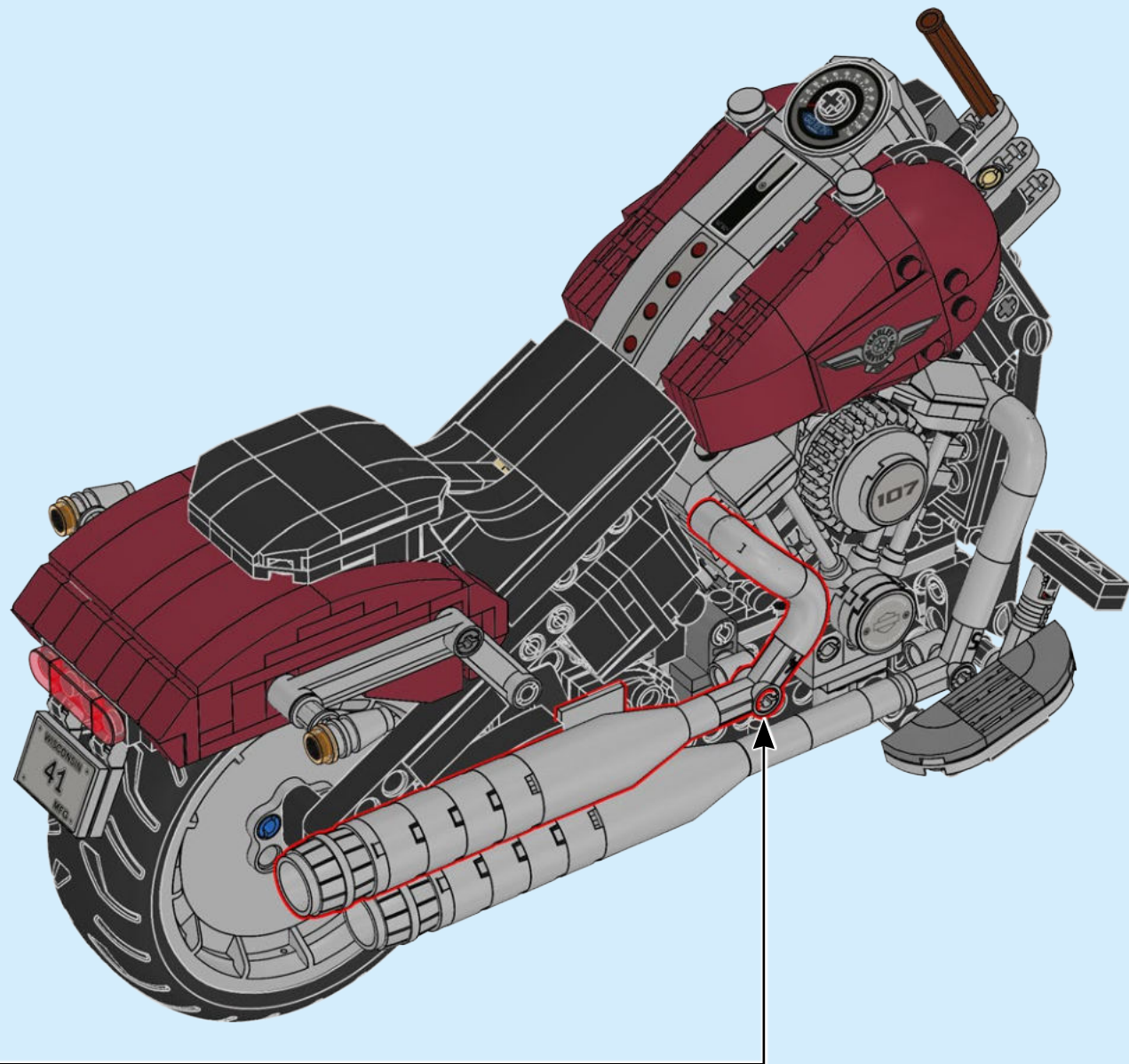

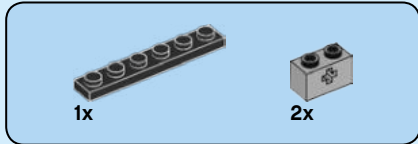
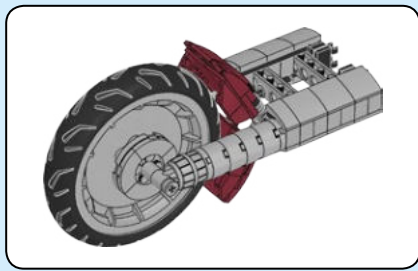

217

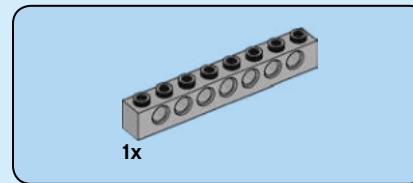
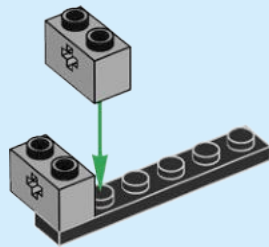

218

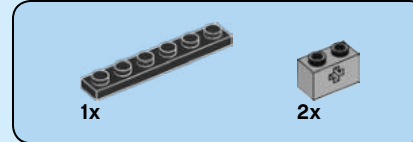
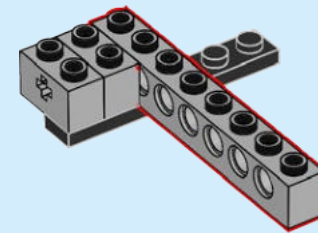

219

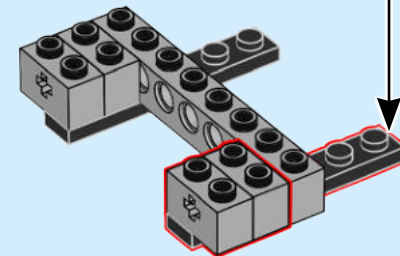
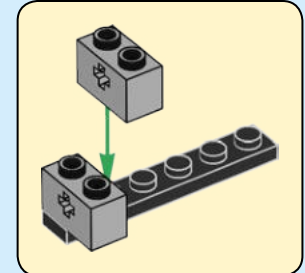





4x

# 220

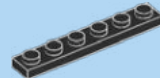
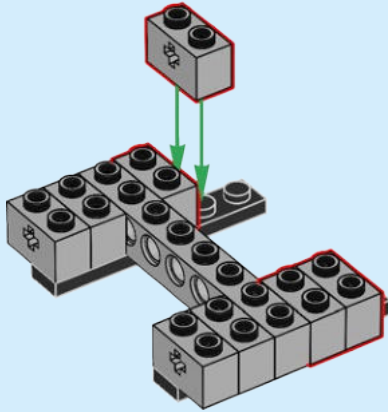

2x

# 222

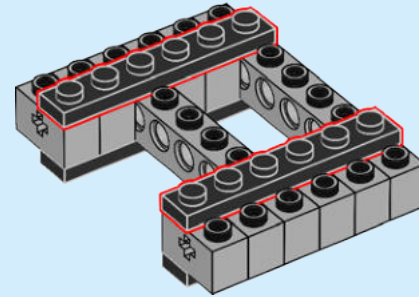

1x

# 221

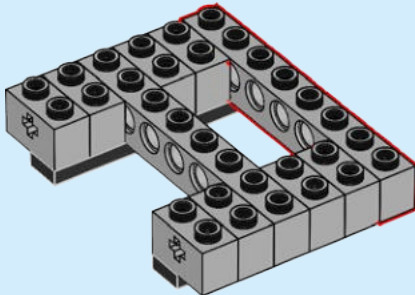

2x

# 223

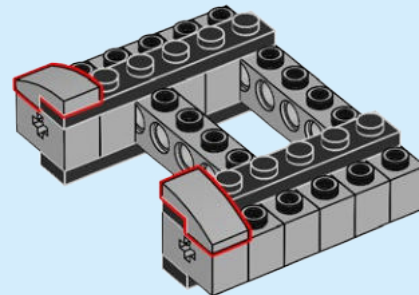



6x

# 224

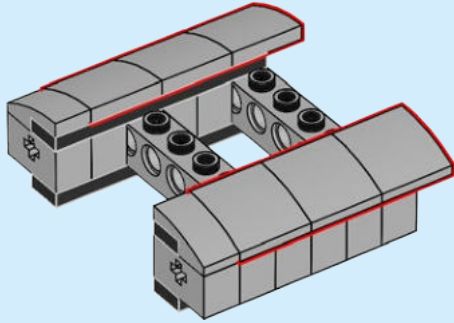

2x



2x

# 225

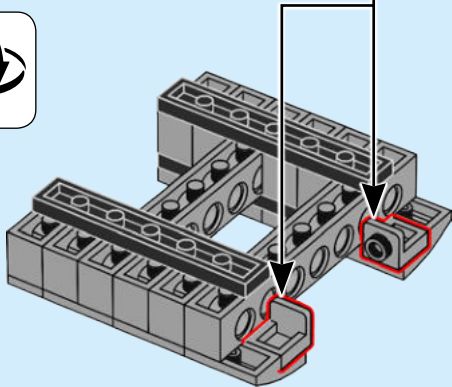

2x

# 226

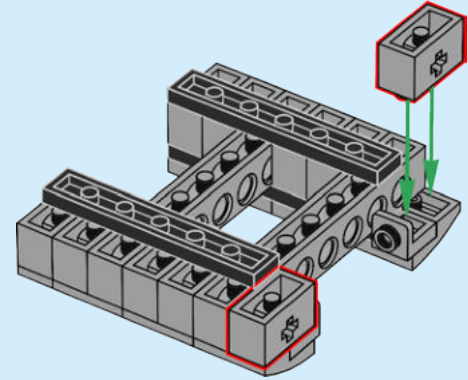

2x



2x

# 227

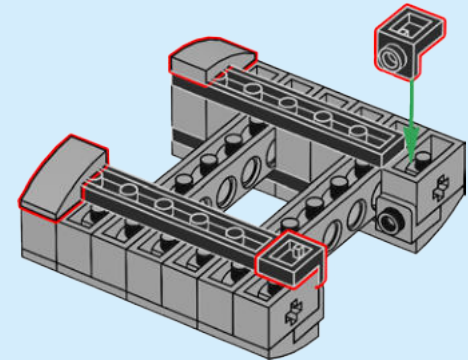



6x

# 228

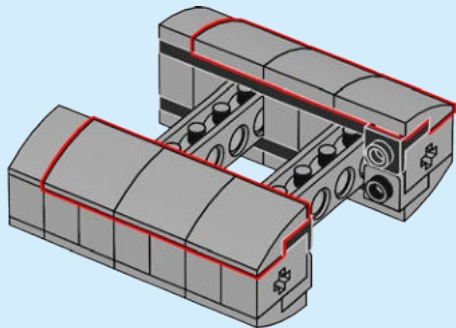

2x



2x

# 229

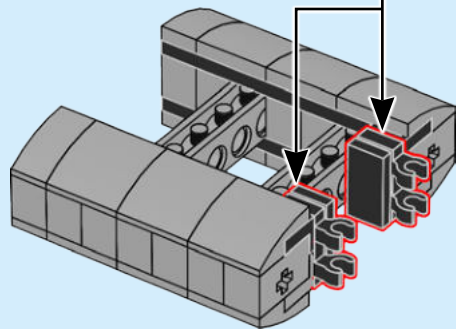
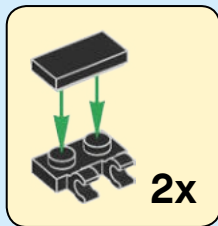

2x



2x

3

# 230



3

# 1:1

3

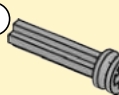

2x

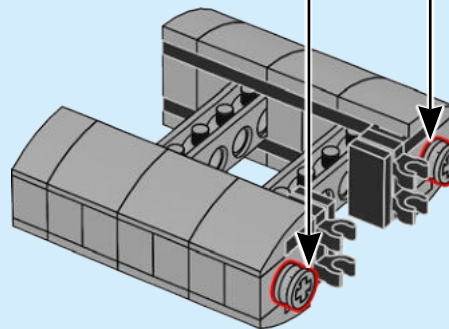

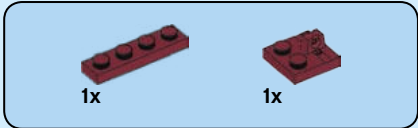
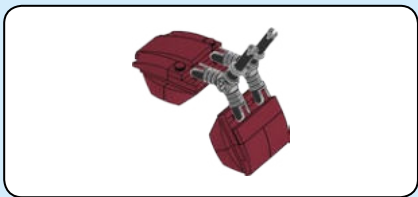

231

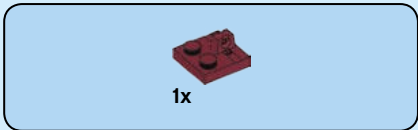
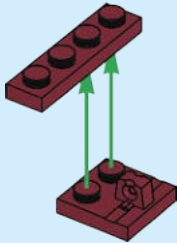

232

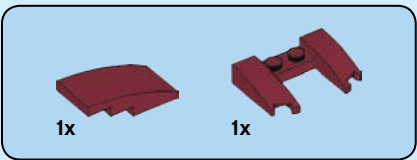
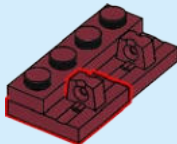

233

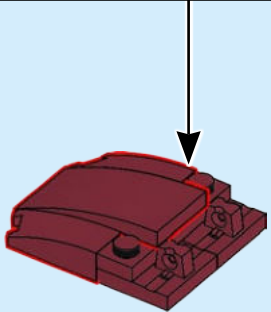
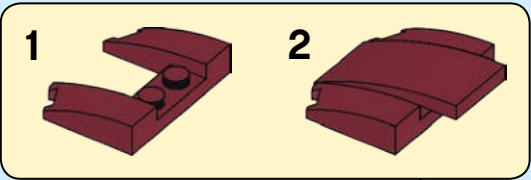

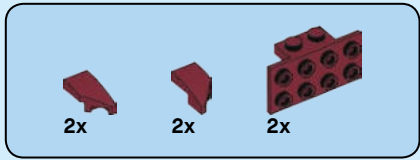

234

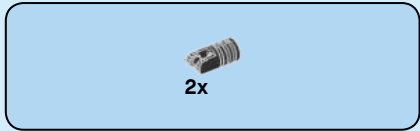
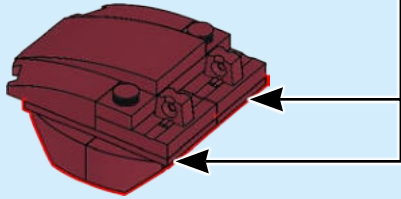
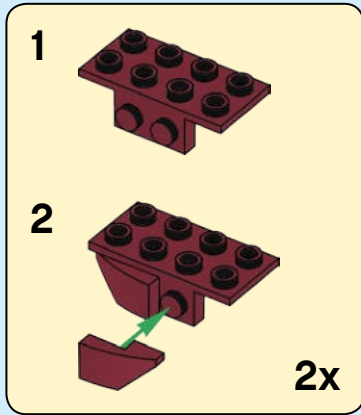

235

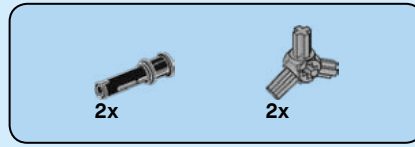
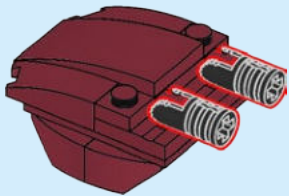

236

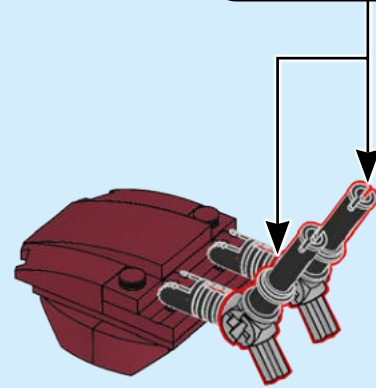
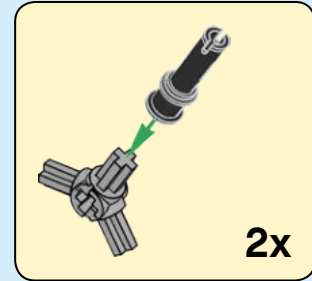



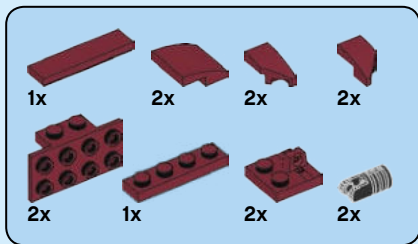

# 237

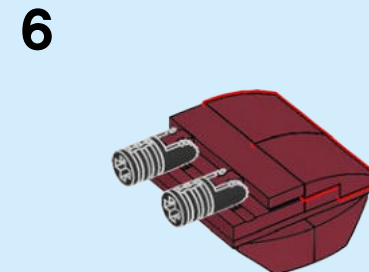
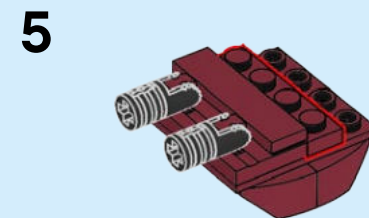
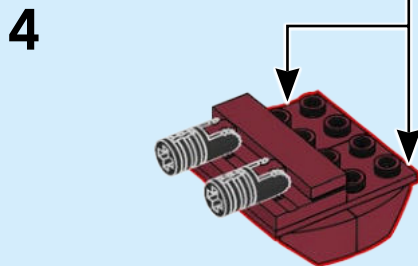
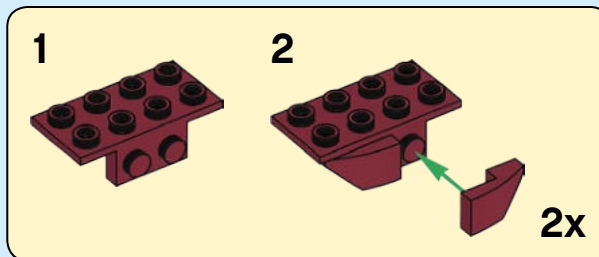
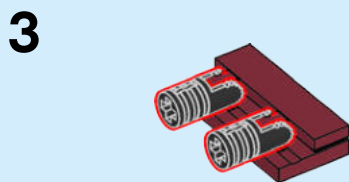
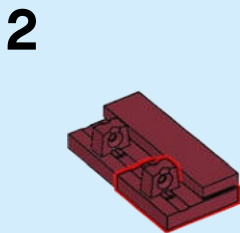
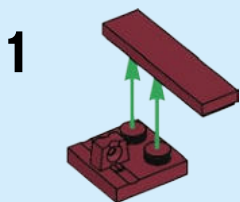

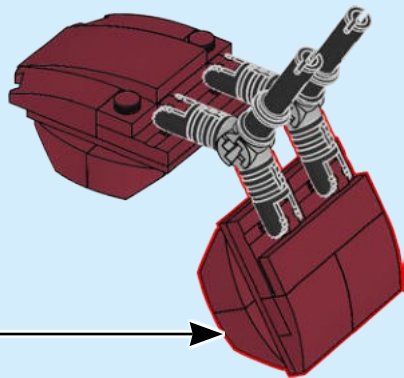

238

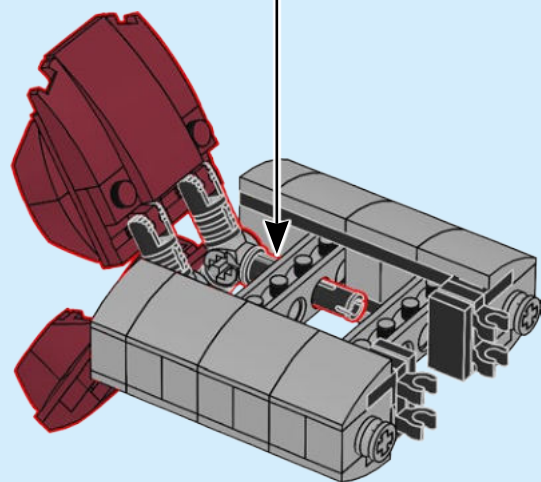

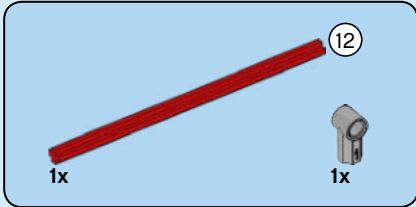
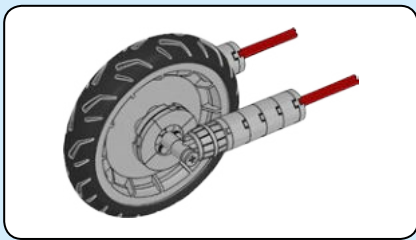

239

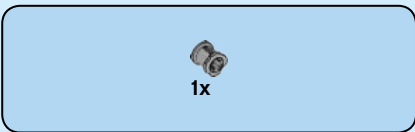
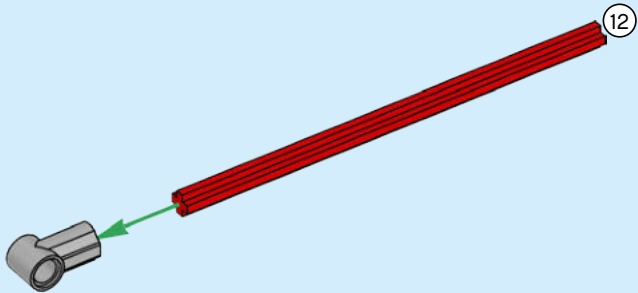

240

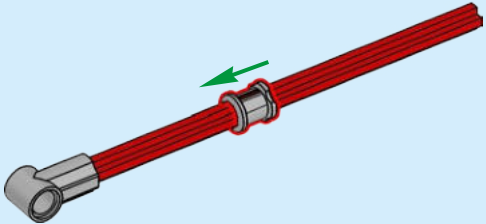

241

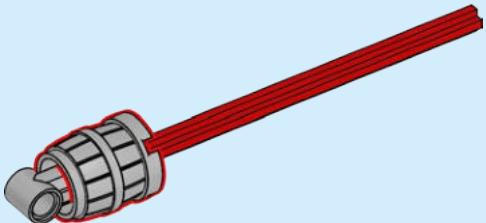



4x

# 242

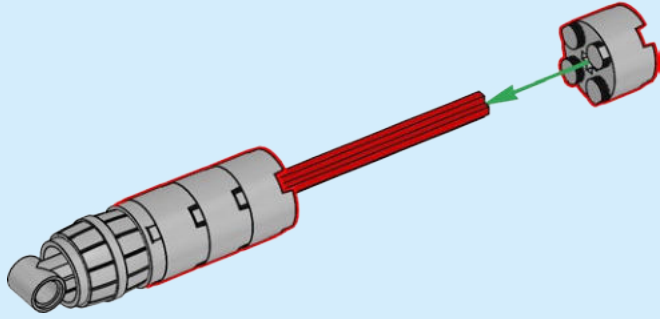

1x

# 243

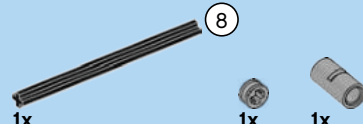
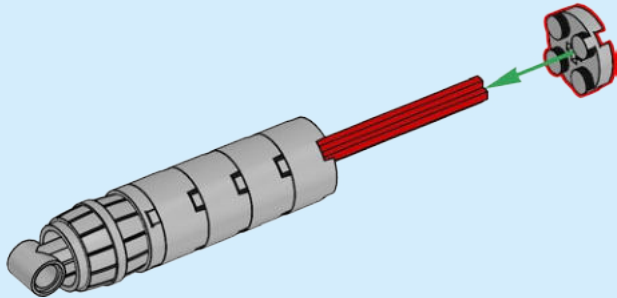

1x

8

1x

1x

# 244

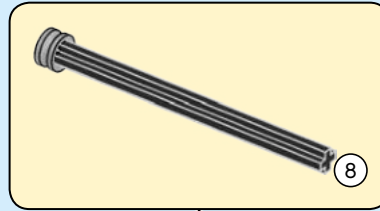

8

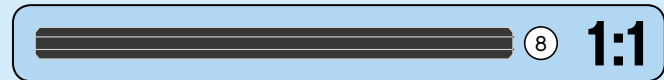
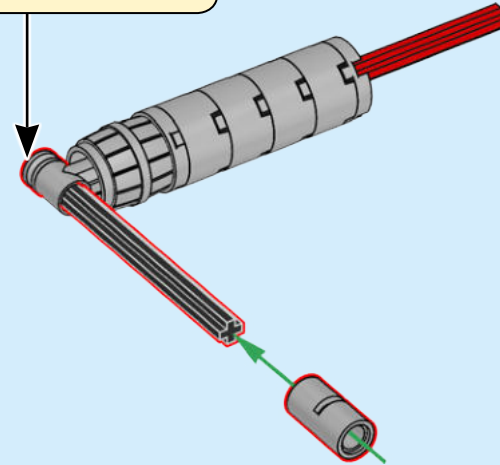

8

1:1

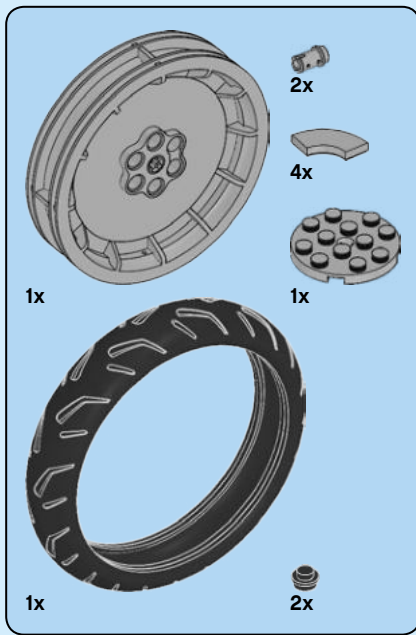

245

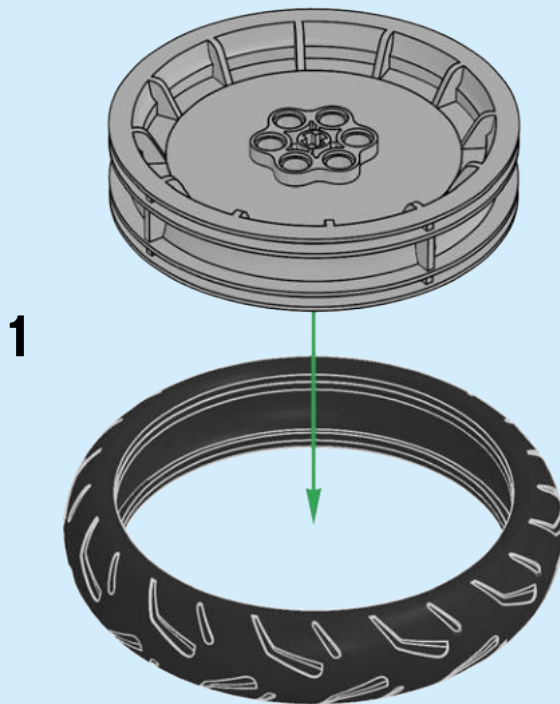

2

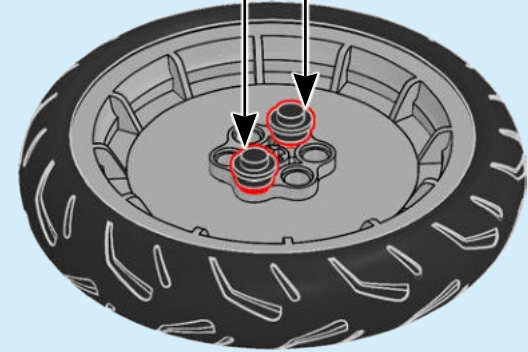
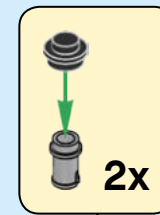

1

2

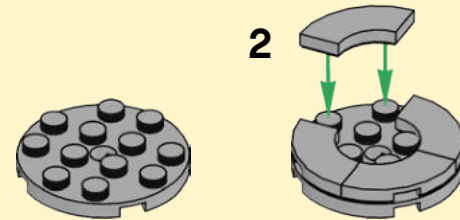

3

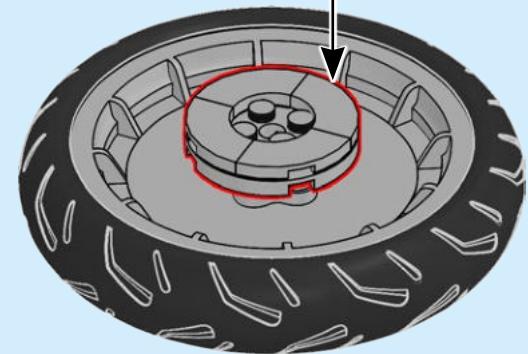



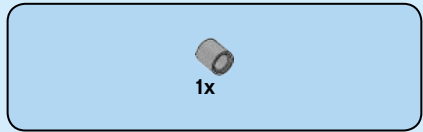

246

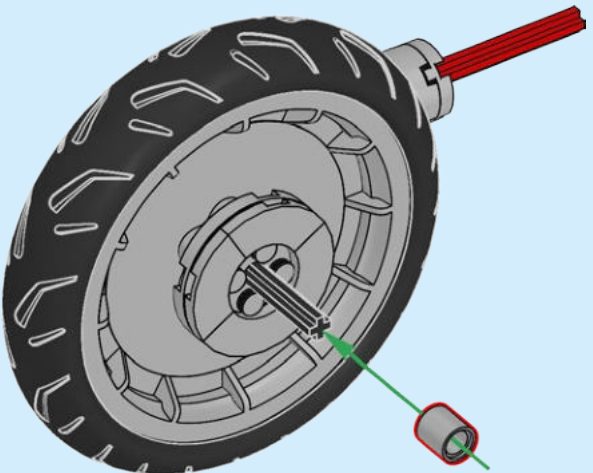
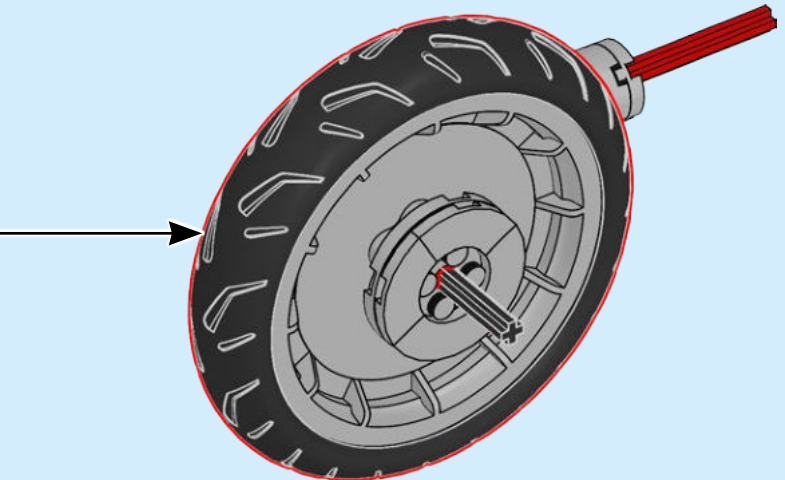

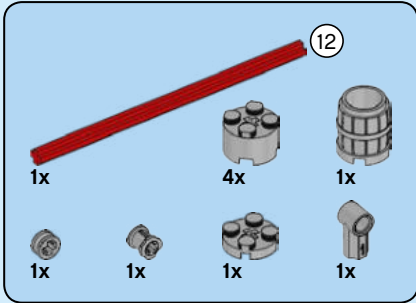
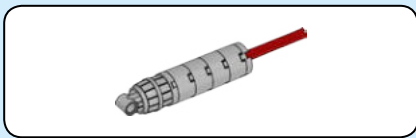

# 247

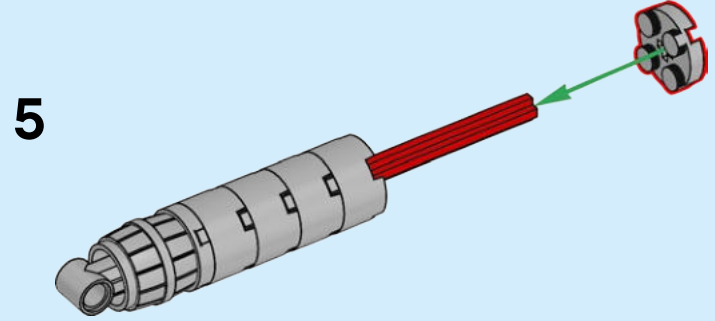
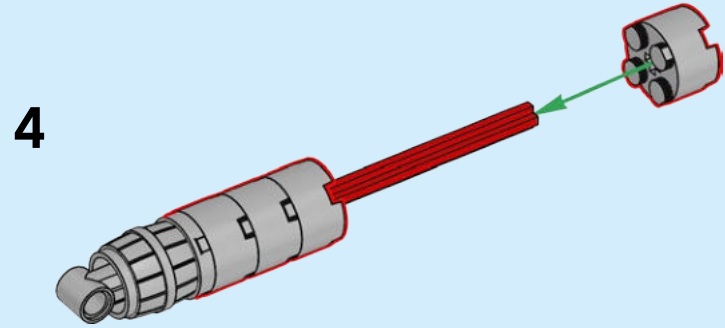
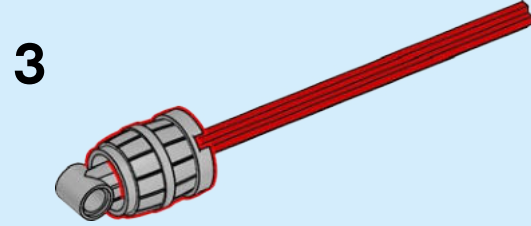
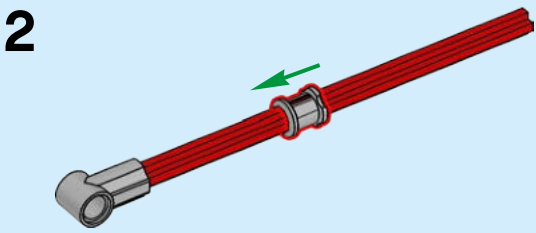
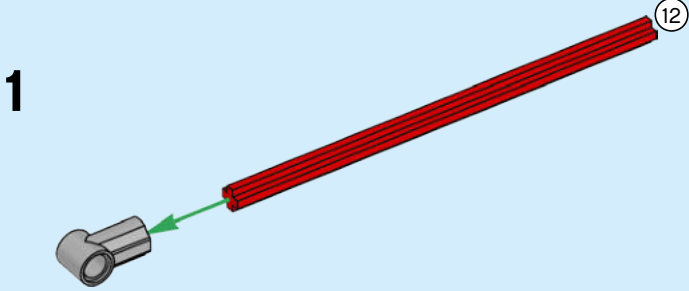

248

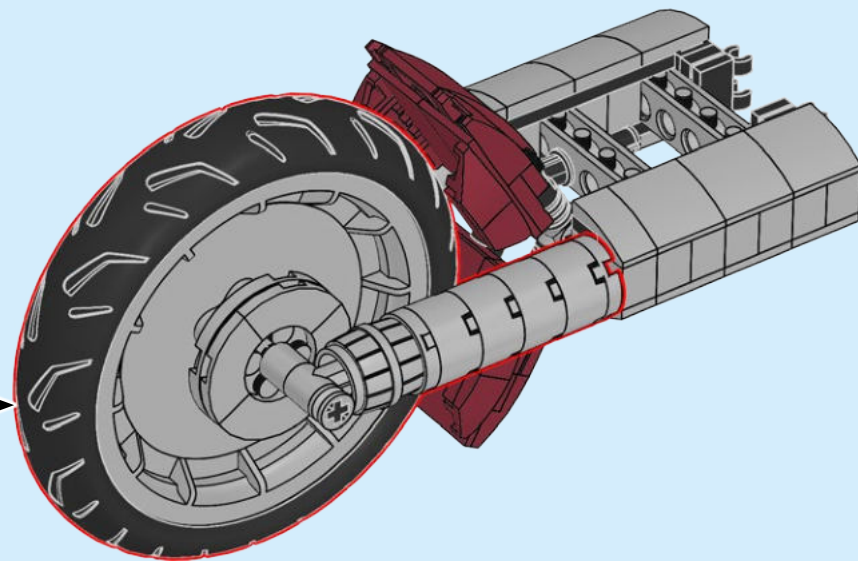
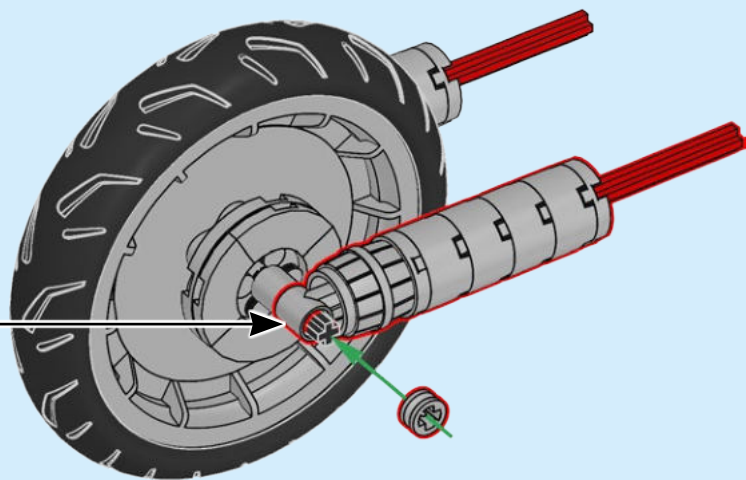

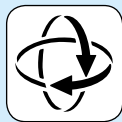

249

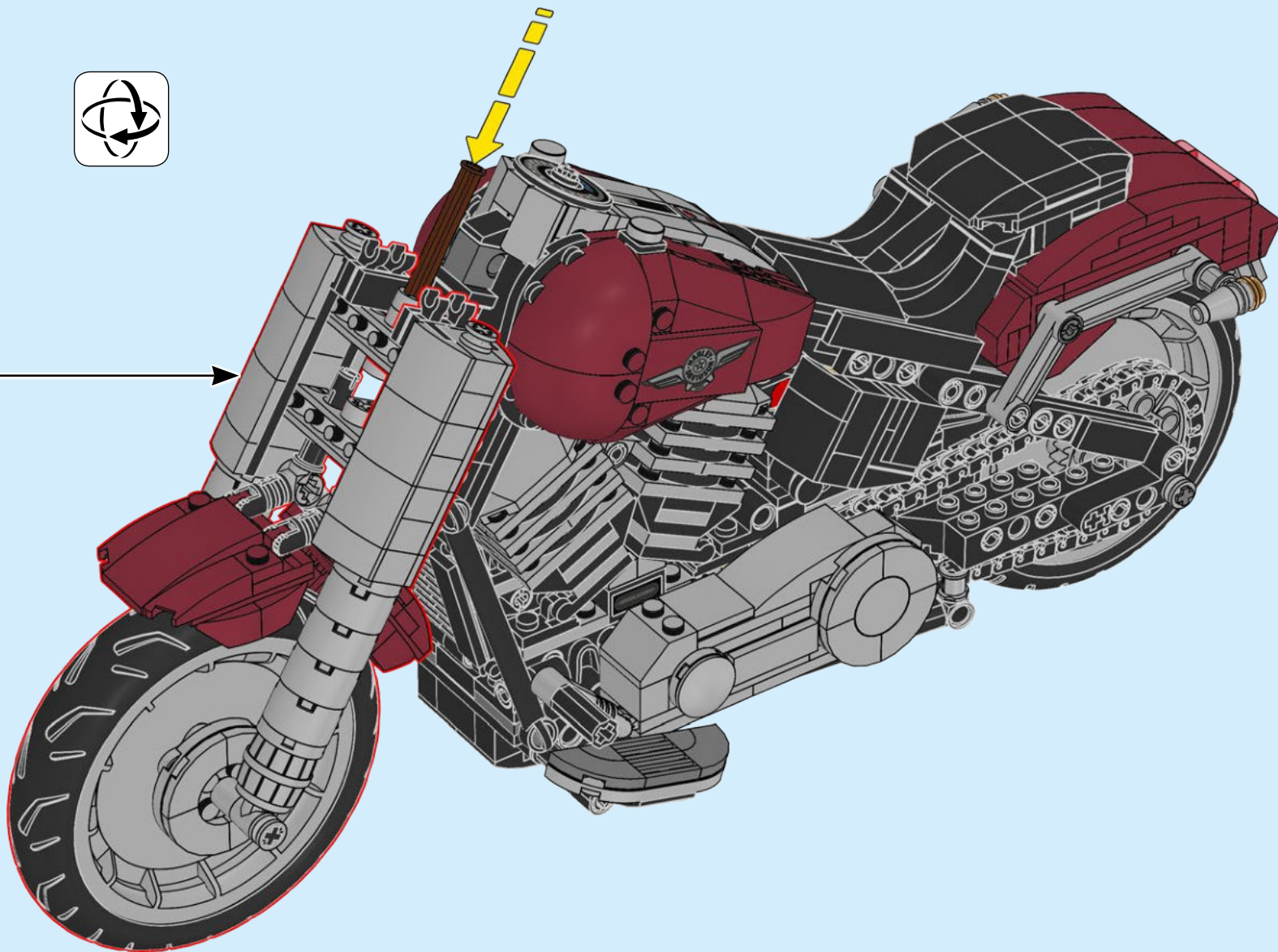

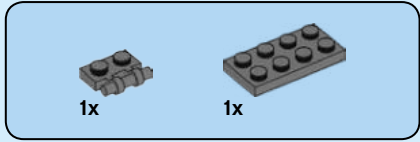

250

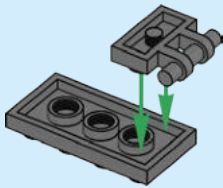

251

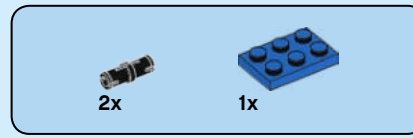
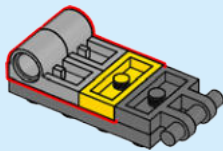

252

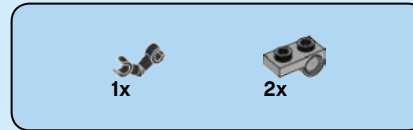
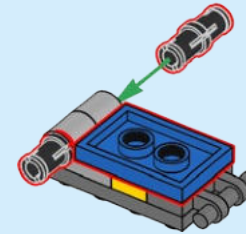

253

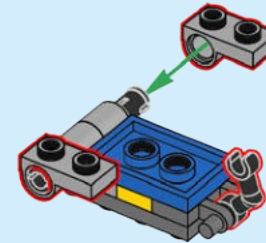



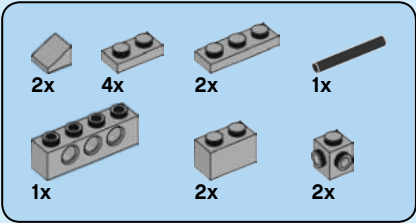
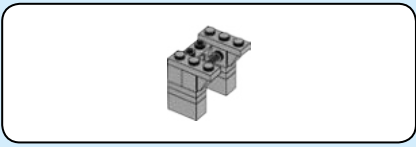

# 254

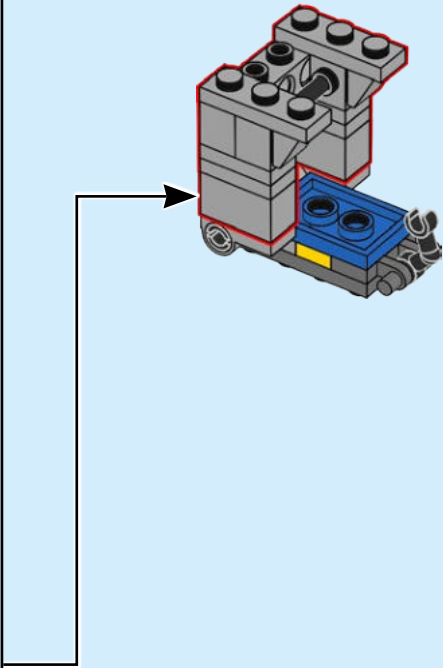
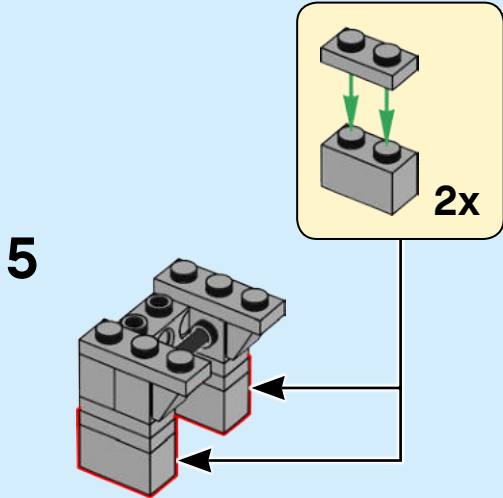
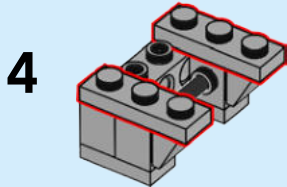
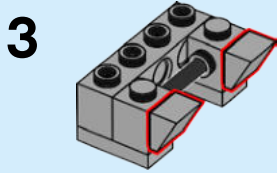
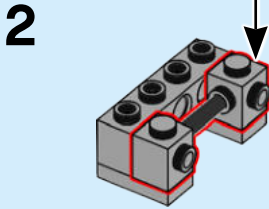
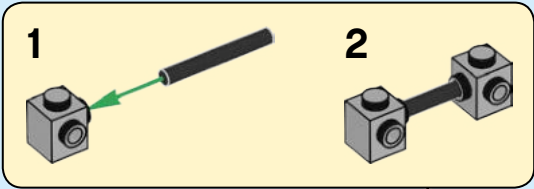
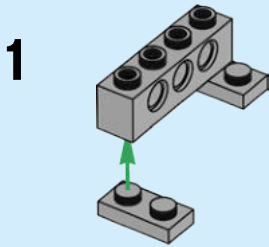

# 255

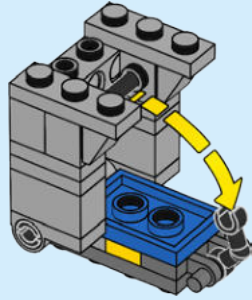

3x

# 256

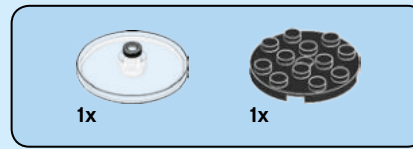
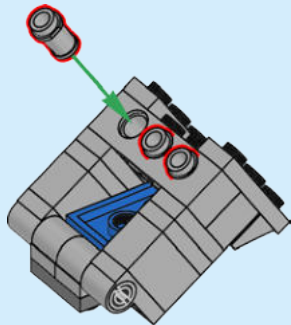

1x

1x

# 257

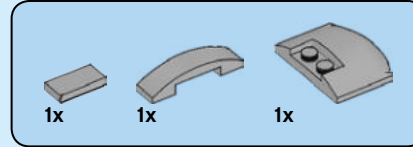
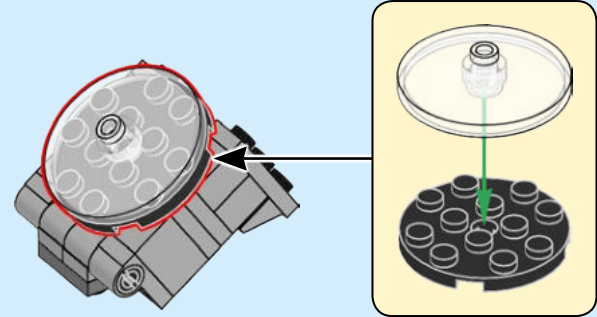

1x

1x

1x

# 258

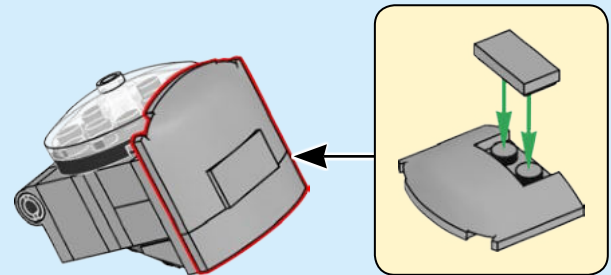

259

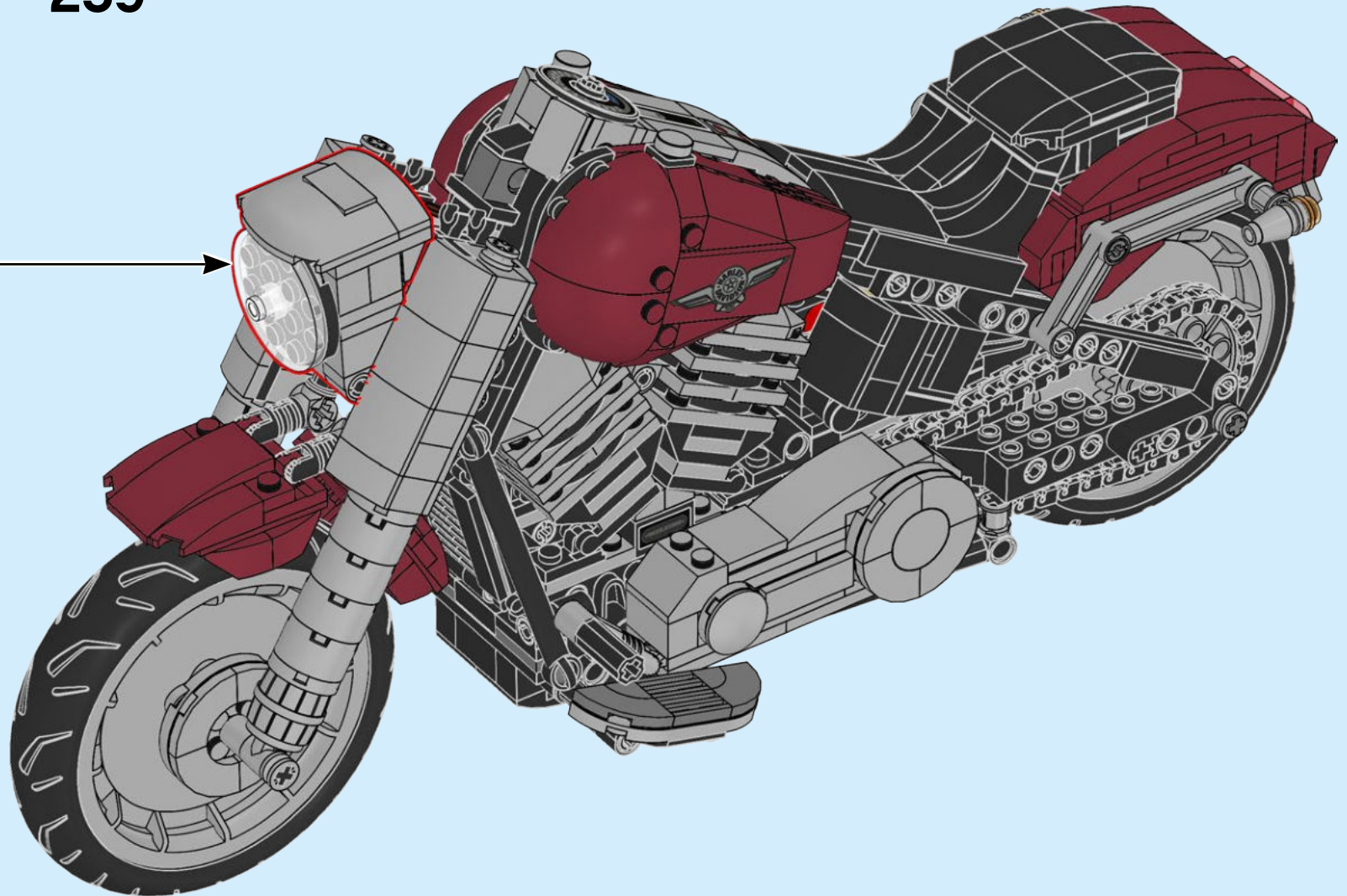

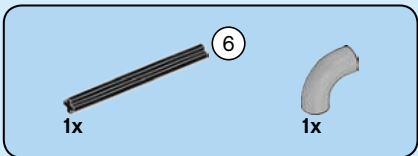
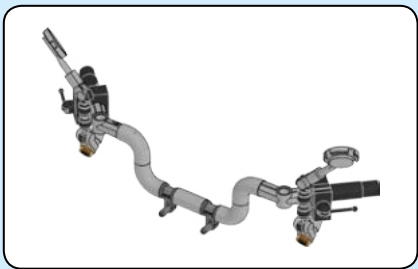

260

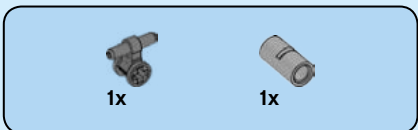
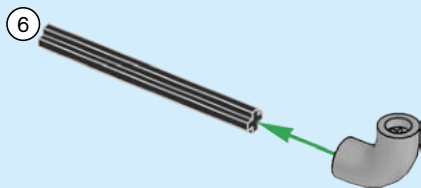

261

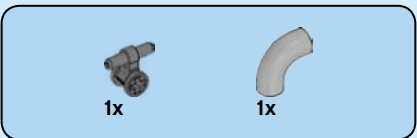
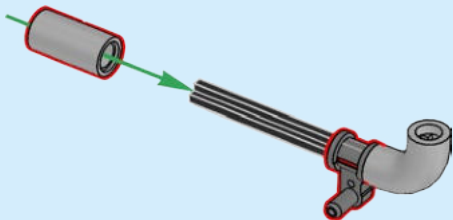

262

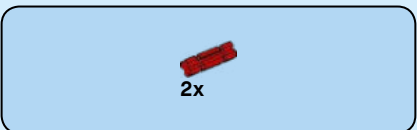
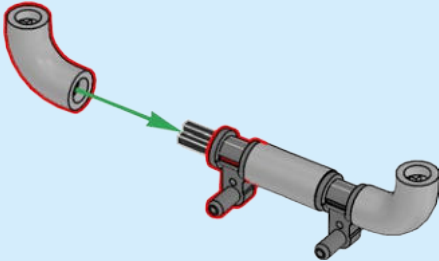

263

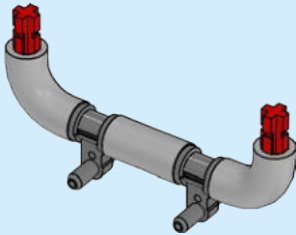

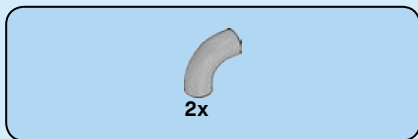

**264**

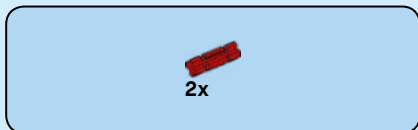
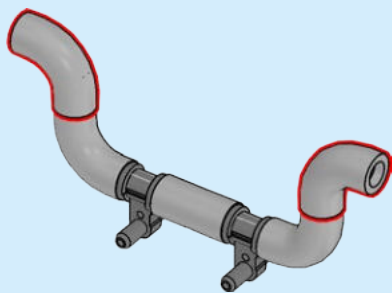

**265**

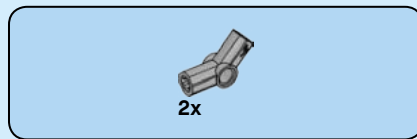
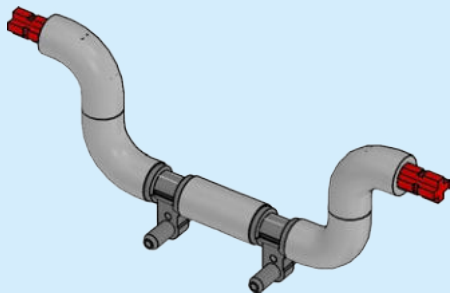

**266**

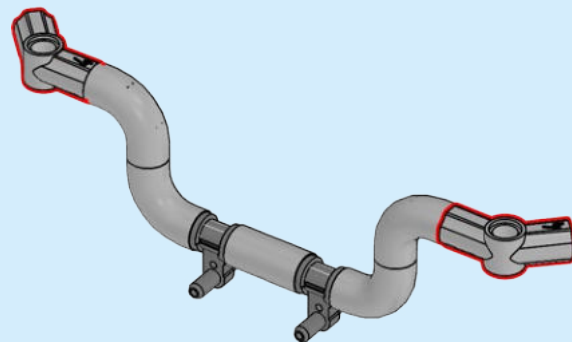



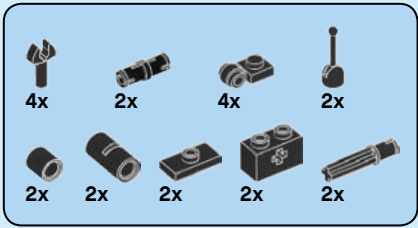

267

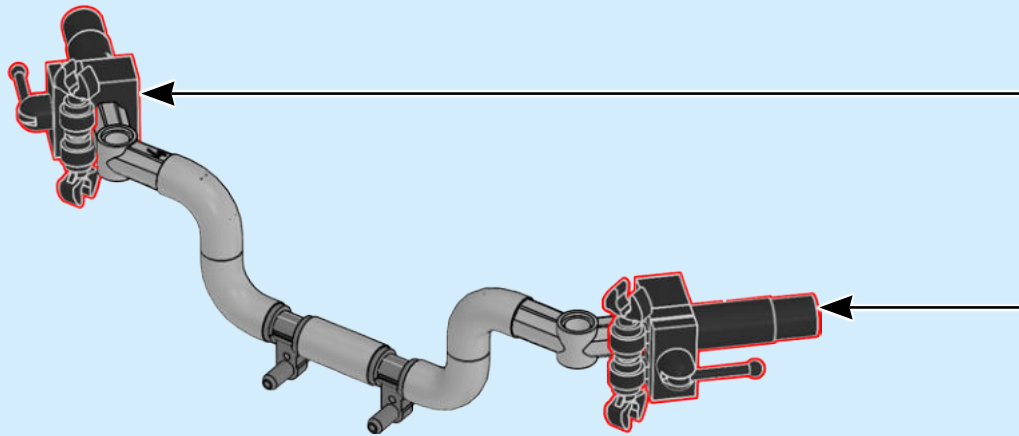
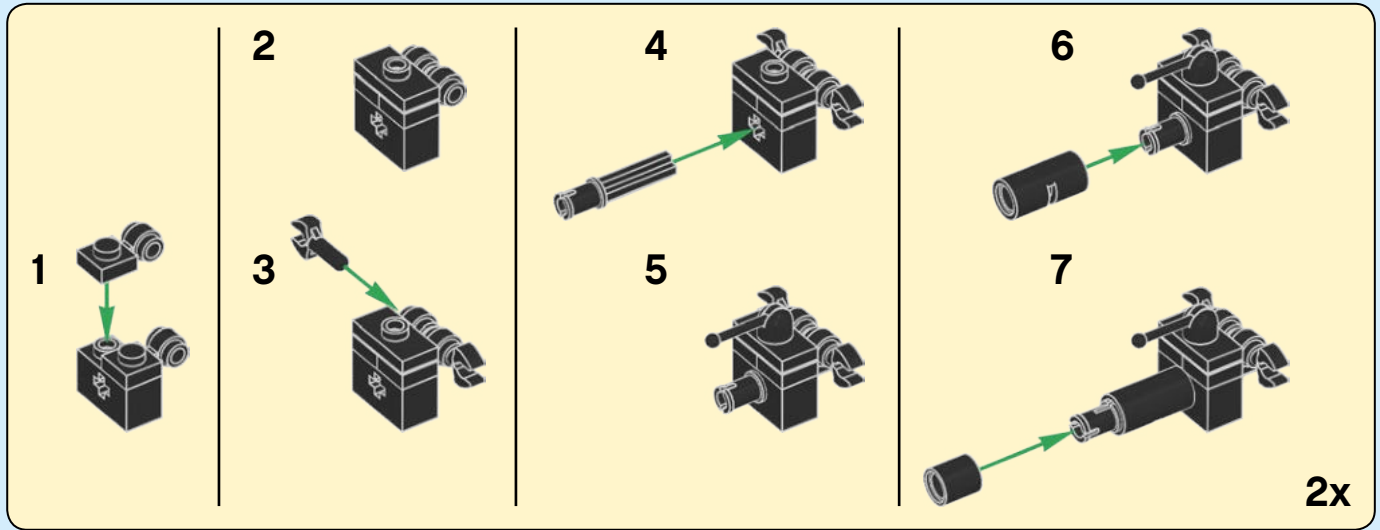

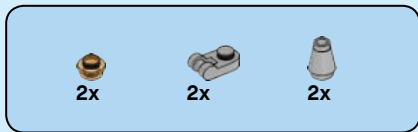

268

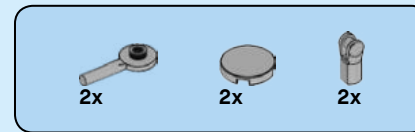
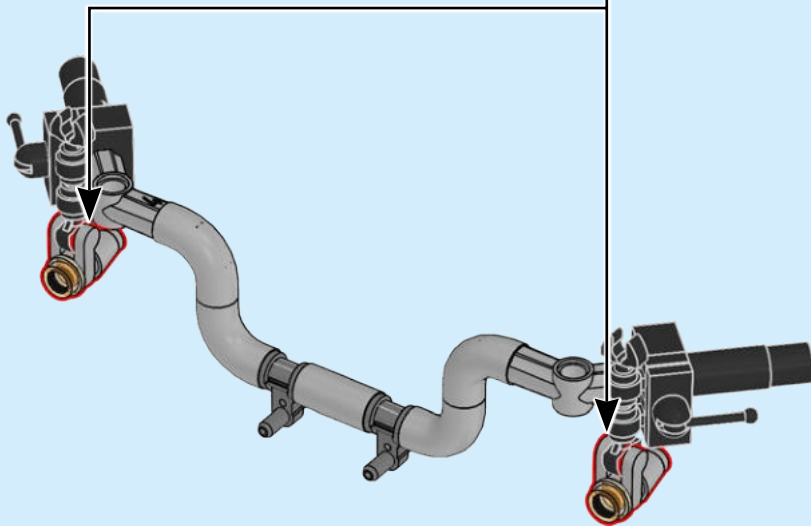

269

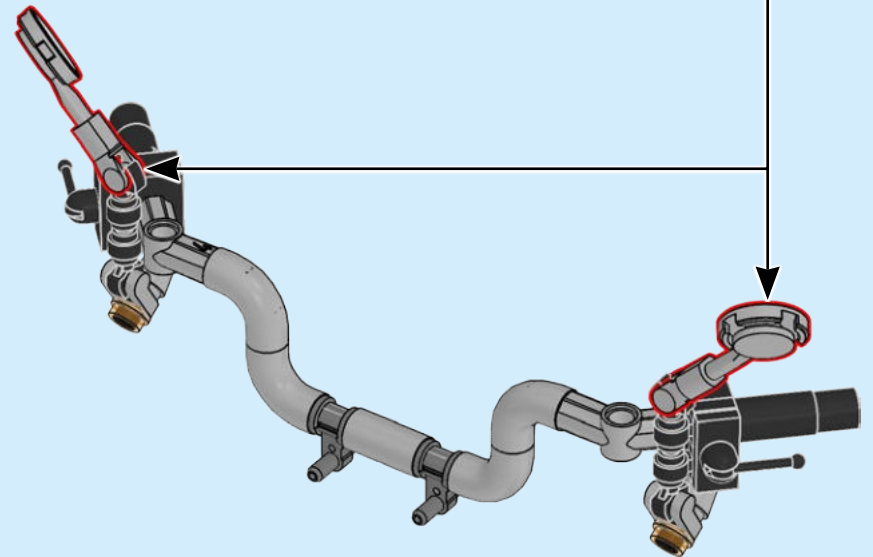
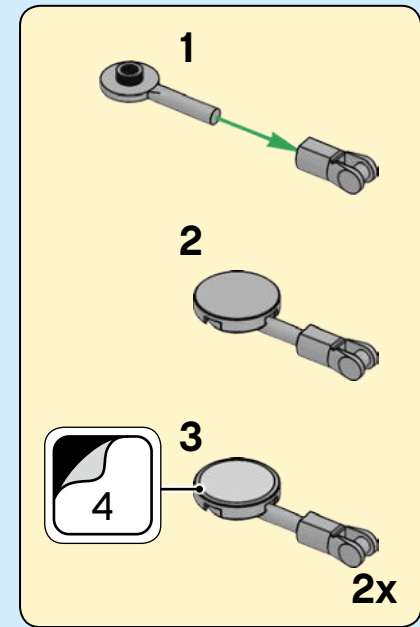

270

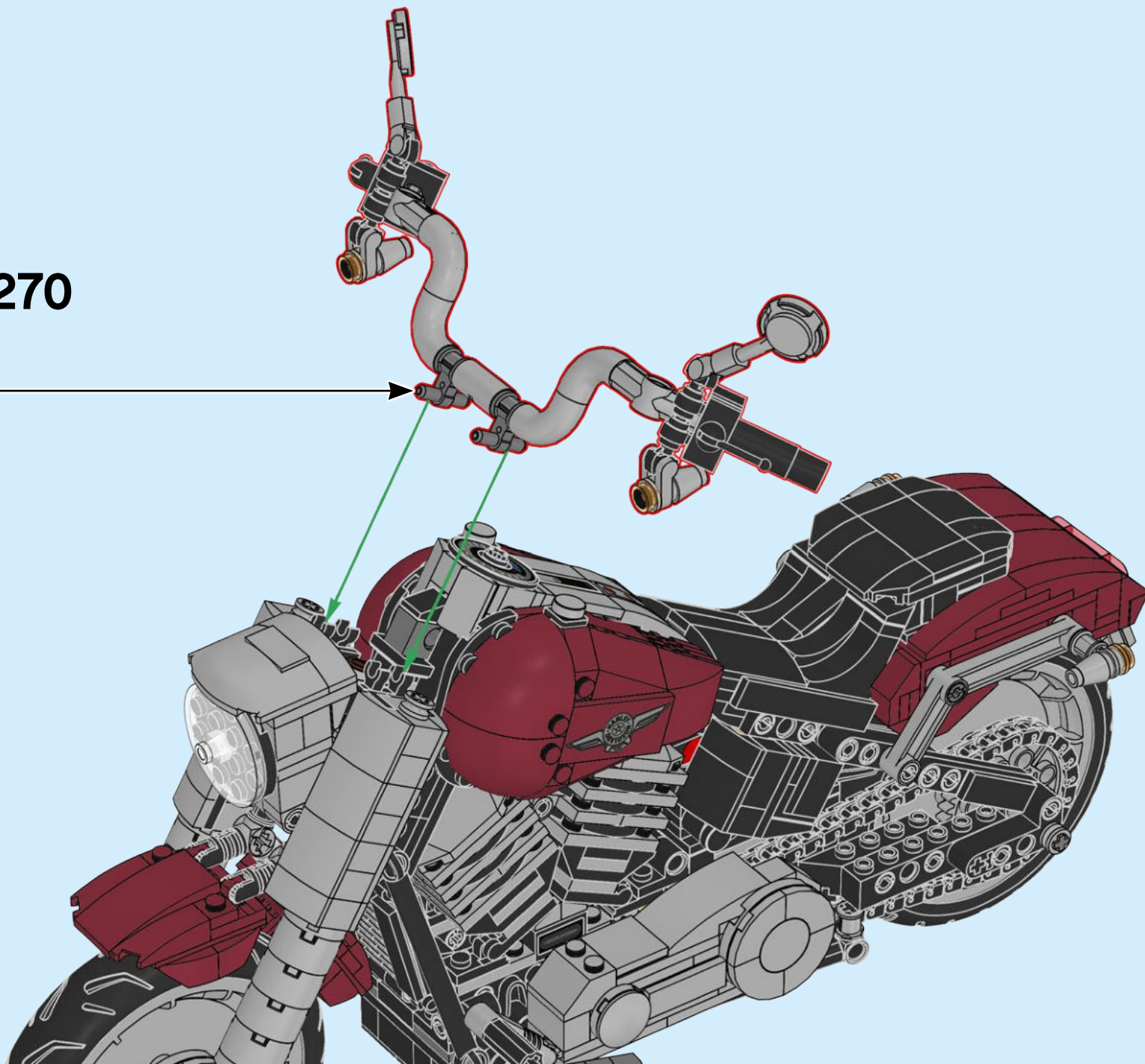

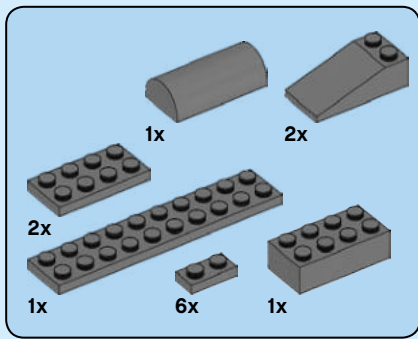

271

1

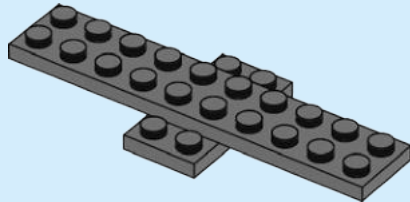

2

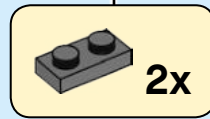
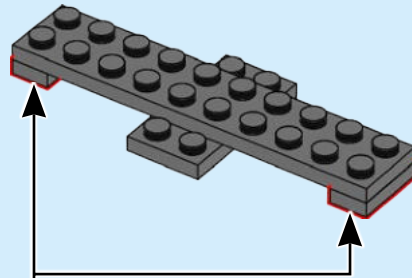

3

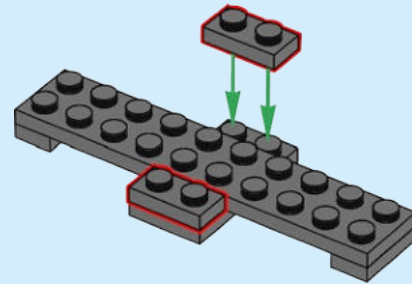

4

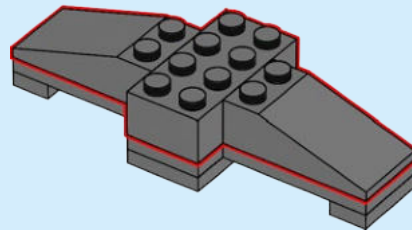

5

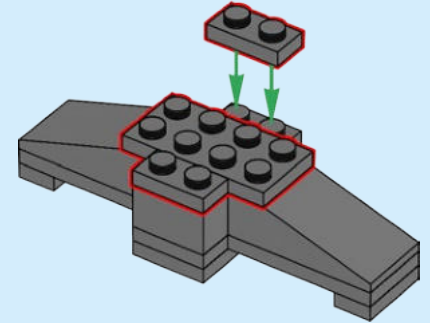

6

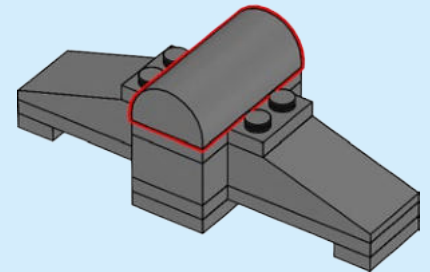



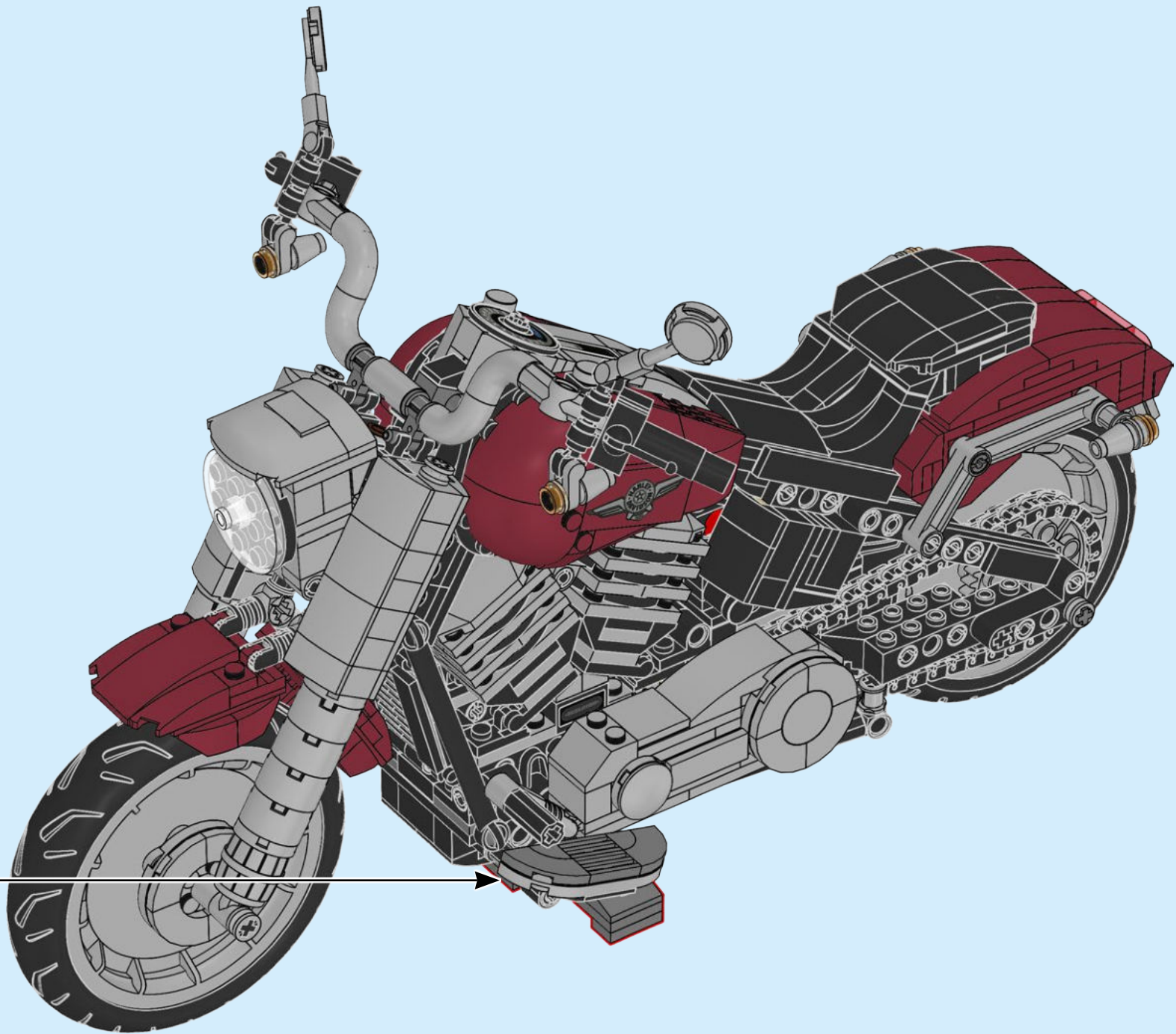



1

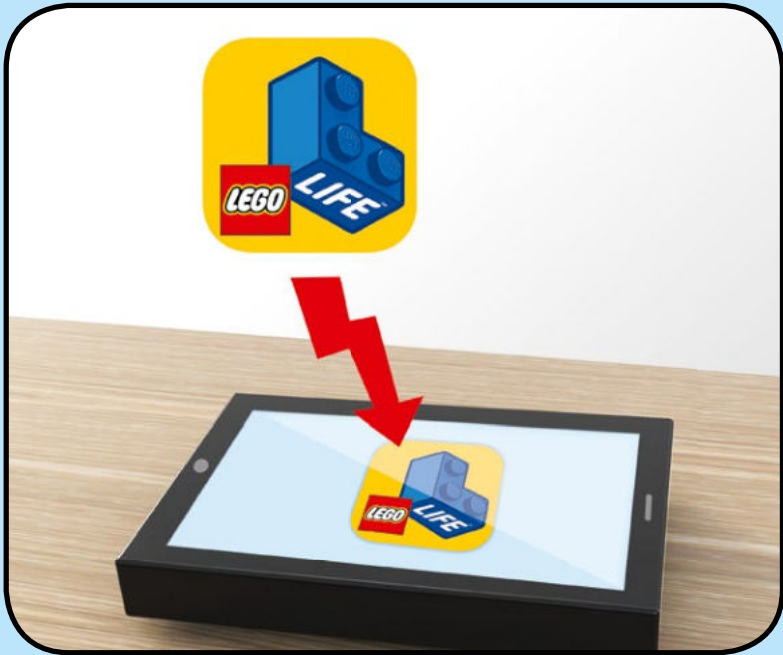

2



3





# CREATOR™

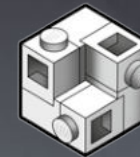

EXPERT

# LICENCE TO BUILD



ASTON MARTIN

# 007™

007™ and related James Bond Trademarks © 1962-2018 Danjaq, LLC and United Artists Corporation.  
007™ and related James Bond Trademarks are trademarks of Danjaq, LLC. All Rights Reserved.  
[www.007.com](http://www.007.com)

Aston Martin, the Aston Martin Wings logo and the model name DB5 are trademarks owned, licensed or used by Aston Martin Lagonda Limited. All rights reserved.





# CREATOR™



## EXPERT



10265



Ford Trademarks and Trade Dress used under license to the LEGO group of companies.

- 2x 6223427
- 10x 4142865
- 1x 6261351
- 3x 370021
- 2x 6209519
- 1x 4153718
- 1x 6129995
- 1x 4142132
- 2x 6147702
- 1x 4540040
- 6x 302324
- 2x 301024
- 2x 4503425
- 2x 6130008
- 1x 4495934
- 2x 6271167
- 2x 4504381
- 2x 6177114
- 4x 6212049
- 2x 6013938
- 2x 6267489
- 6x 4121921
- 4x 4114309
- 5x 4143005
- 6x 4206482
- 9x 4514553
- 3x 302123
- 9x 371023
- 2x 73587
- 1x 4529236
- 2x 6284070
- 3x 6121485
- 14x 614126
- 3x 4558954
- 3x 4504382
- 2x 6181720
- 7x 302426
- 4x 307026
- 1x 4106347
- 4x 6234695
- 43x 6044702
- 2x 4184169
- 2x 6181713
- 2x 4660886
- 1x 6261371
- 1x 6146095
- 2x 6173119
- 4x 4143372
- 2x 4109810
- 30x 4121715
- 3x 4548180
- 4x 4632571
- 1x 6253260
- 1x 6099801
- 3x 4143466
- 2x 4185620
- 2x 4177444
- 2x 4512363
- 6x 3200026
- 3x 6174243
- 3x 6047276
- 1x 6267487
- 2x 6178922
- 2x 4569733
- 6x 6114987
- 4x 6192309
- 14x 302326
- 4x 4598528
- 6x 4541191
- 2x 6069000
- 9x 6092585
- 3x 300426
- 6x 306926
- 2x 4144023
- 2x 6147050
- 2x 6117973
- 2x 4556158
- 2x 6055630
- 1x 4218868
- 6x 4535739
- 1x 6093525
- 2x 4119589
- 3x 6089119
- 2x 6269869
- 4x 302226
- 4x 6053077
- 6x 6211476
- 2x 300326
- 5x 4140801
- 4x 4515368
- 3x 4142822
- 1x 6199908
- 2x 362226
- 4x 362326
- 10x 362326
- 4x 6154860
- 3x 4558170
- 1x 4296142
- 4x 303826
- 2x 6278152
- 2x 6116604
- 1x 6162892
- 7x 302126
- 2x 6271825
- 5x 370126
- 2x 4205760
- 1x 6037746
- 7x 371026
- 1x 365926
- 3x 243126
- 4x 6267482
- 6x 6167800
- 1x 4227392
- 2x 6102782
- 1x 4530589
- 1x 4515350
- 2x 4587844
- 2x 302026
- 1x 4142135
- 2x 4142823
- 1x 6269866
- 2x 4114634
- 2x 6105963
- 1x 6280168
- 2x 663626
- 13x 366626
- 2x 389426
- 2x 370626
- 1x 4243819
- 1x 370726
- 1x 6170702
- 2x 370226
- 2x 416226
- 1x 303226
- 2x 6244698
- 1x 4645732
- 1x 373726
- 1x 6261718
- 2x 389526
- 1x 6264060
- 2x 370326
- 1x 6252205
- 2x 6264033
- 2x 4210637
- 1x 4508553
- 1x 4210678
- 1x 4211137
- 2x 6083620
- 1x 4590786
- 3x 4211065
- 1x 4211085



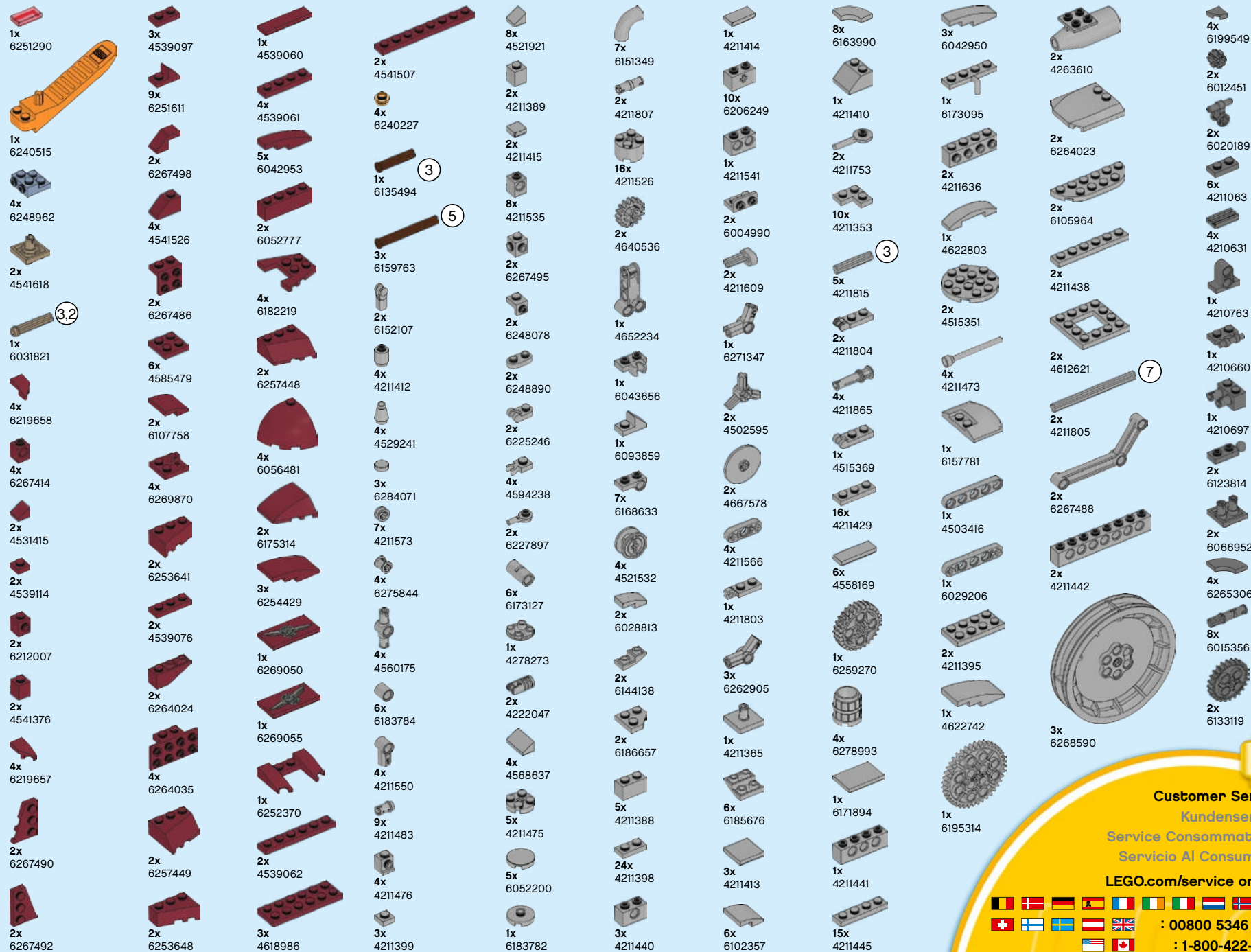

**Customer Service**  
 Kundenservice  
 Service Consommateurs  
 Servicio Al Consumidor  
**LEGO.com/service or dial**



**: 00800 5346 5555**  
**: 1-800-422-5346**



# WIN

GO TO [WWW.LEGO.COM/PRODUCTFEEDBACK](http://WWW.LEGO.COM/PRODUCTFEEDBACK) AND  
GIVE US YOUR SHORT **FEEDBACK** ABOUT THIS  
LEGO® SET FOR A CHANCE TO WIN  
A COOL LEGO PRIZE.

Terms & Conditions apply

## [LEGO.com/productfeedback](http://LEGO.com/productfeedback)

### GEWINNE

Erzähle uns auf  
[www.LEGO.com/productfeedback](http://www.LEGO.com/productfeedback)

etwas über die Erfahrungen, die  
du mit diesem LEGO® Set gemacht  
hast, und sichere dir die Chance  
auf einen coolen LEGO Preis!

Es gelten die  
Teilnahmebedingungen

### GAGNE

Rends-toi sur  
[www.LEGO.com/productfeedback](http://www.LEGO.com/productfeedback)

et donne-nous quelques com-  
mentaires sur ce produit LEGO®  
pour avoir une chance de gagner  
un prix LEGO !

Voir Conditions Générales

### GANAN

Visita  
[www.LEGO.com/productfeedback](http://www.LEGO.com/productfeedback)

y envíanos tu opinión acerca de  
este set LEGO®. ¡Participarás en el  
sorteo de un premio LEGO!

Términos y Condiciones aplicables

### 获取奖品

登录  
[www.LEGO.com/productfeedback](http://www.LEGO.com/productfeedback)

给出关于此乐高®套装的简短反馈，  
就有机会获得炫酷乐高奖品

《条款及条件》适用

### 경품 당첨 기회

[www.LEGO.com/productfeedback](http://www.LEGO.com/productfeedback)

페이지로 이동하여 이 레고® 세트에  
대한 간략한 피드백을 보내 주시고  
멋진 레고 경품을 탈 수 있는 기회도  
잡으십시오

약관 적용

### ЗАПОЛНИ АНКЕТУ И ПОЛУЧИ ПРИЗ

Перейди по ссылке  
[www.LEGO.com/productfeedback](http://www.LEGO.com/productfeedback)

ответь всего на несколько во-  
просов об этом наборе LEGO®,  
и у тебя появится шанс выиграть  
замечательный приз от компании  
LEGO.

Применяются Условия и правила  
участия

LEGO and the LEGO logo are trademarks of the LEGO Group. ©2019 The LEGO Group.

©2019 H-D or its affiliates. HARLEY-DAVIDSON, HARLEY, H-D, and the Bar and Shield Logo are among the trademarks of H-D U.S.A., LLC. Third-party trademarks are the property of their respective owners.

6283511