



31197

Booklet available in English on  
Heft in deutscher Sprache erhältlich auf  
Livret disponible en français sur  
Libretto disponibile in italiano su  
Folleto disponible en español en  
如需中文版手册, 请访问





Imagine crafting your own wall art. Maybe it's a passion that fascinates you, or maybe it's the promise of an immersive creative experience like no other: a piece of iconic art you can build from scratch, paired with a unique soundtrack curated around the world of Andy Warhol. You can listen as you build, at your own pace, and get the inside story. Relax and reconnect with your creative side. Create something you'll love and give your living space a touch of the iconic.



Your LEGO® Art set is created by Senior Designer Kitt Kossmann and Design Lead Christopher Stamp

WELCOME TO LEGO® ART. READY TO DIVE IN?



Andy Warhol

# Andy Warhol by Andrew Warhola

The man who once quipped he "came from nowhere" was born Andrew Warhola in 1928. Raised in Pittsburgh, PA, he became a successful commercial illustrator in 1950's

Manhattan. From there he would go on to shock the art world, cross over into mainstream celebrity, and democratise art with his wildly accessible work drawing from mass culture, everyday objects and the seemingly mundane.

By choosing to be at once enigmatic and overexposed – Truman Capote once described him as "a sphinx without a secret" – Andrew Warhola turned the Andy Warhol persona into his greatest creation.



## Warhol at Work

A true multimedia artist, during his four-decade tenure Warhol created paintings, drawings, sculptures, fashion designs, photographs and up to 610 'time capsules' filled with objects from his daily life. Obsessed with applying industrial-style production methods to art, Warhol perfected the silkscreen printing technique in his New York studio, which he named 'The Factory.'



Art is what  
you can get away with

Andy Warhol

The Factory was more than an art studio.  
It was a hangout for bohemians, free-thinkers and  
socialites, known as the Warhol Superstars.





Warhol's iconic celebrity portraits are some of his most recognisable pieces, but his subject matter stretched well beyond the human form.



# About the Andy Warhol Foundation for the Visual Arts, Inc.

Since its founding in 1987, in accordance with Warhol's will, The Andy Warhol Foundation has established itself among the leading funders of contemporary art in the United States. The Foundation has distributed over USD 200,000,000 in cash grants which support the creation, presentation and documentation of contemporary visual arts, particularly work that is experimental, under-recognised or challenging in nature. Proceeds the Foundation receives from licensing projects such as this contribute to the Foundation's endowment from which these grants are distributed.



*Marilyn Monroe (Marilyn), 1967*

Warhol based his colourful portraits of Marilyn on a black and white publicity photograph of the actress from her 1953 film Niagara. In true form, he'd sell them for as little as USD 250.

# Marilyn Made by You

Only a few other figures embody the turbulent glamour of 1960's America like Marilyn Monroe. Andy Warhol began working on his first set of Marilyn portraits shortly after her death. In 1998, one of those portraits would set the record as the highest price paid for a Warhol piece at the time - USD 17.3 million. The portrait of Marilyn you now own is a quintessentially Warholian piece of art - an icon recreated by an icon. Now it's your turn. Happy building!

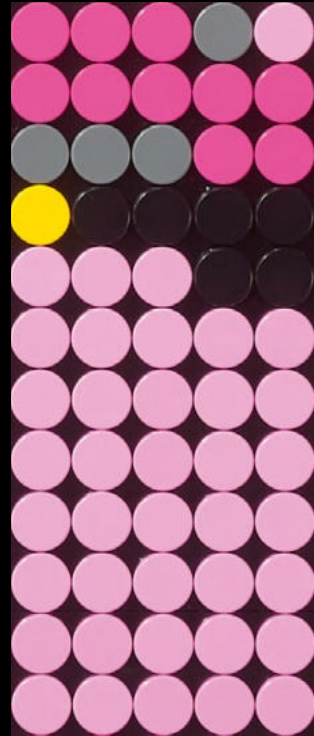





## LISTEN

Start your exclusive unique soundtrack and immerse yourself in the world of Andy Warhol.

## BUILD

Follow the simple instructions in this book to create your iconic piece of art.

## RELAX

LEGO® Art is the perfect way to disconnect, de-stress and recharge.



[LEGO.com/brickseparator](https://www.lego.com/brickseparator)

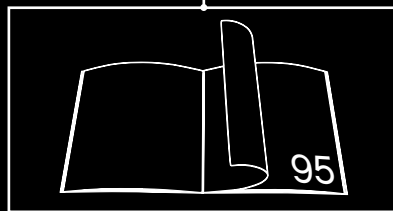
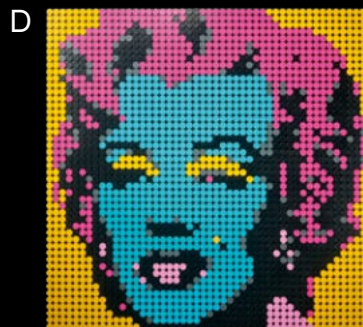
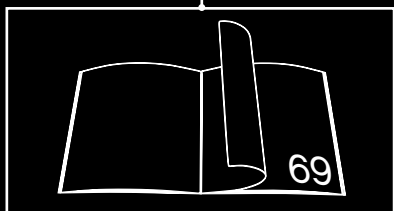
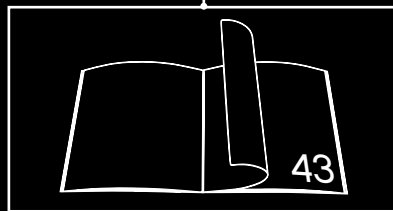
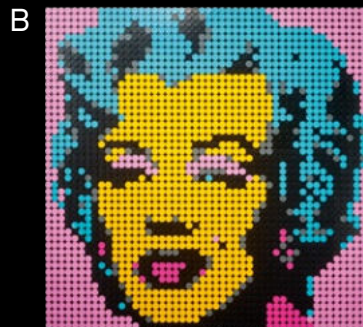
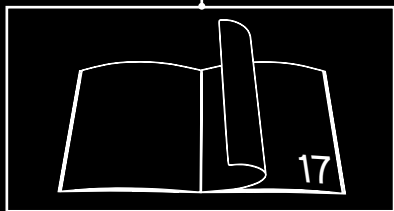





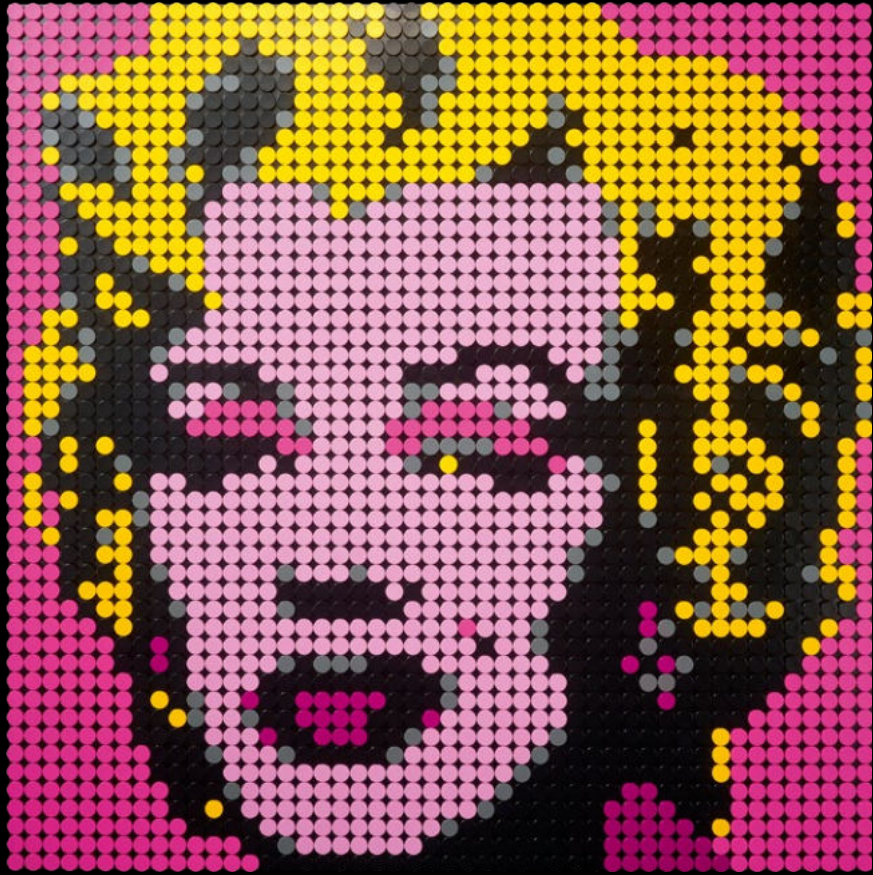

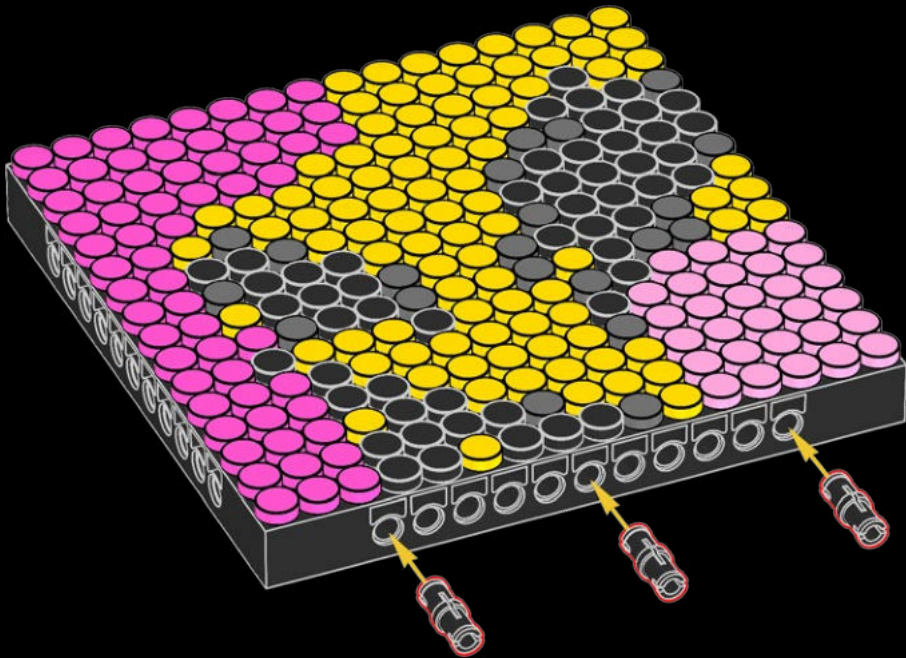

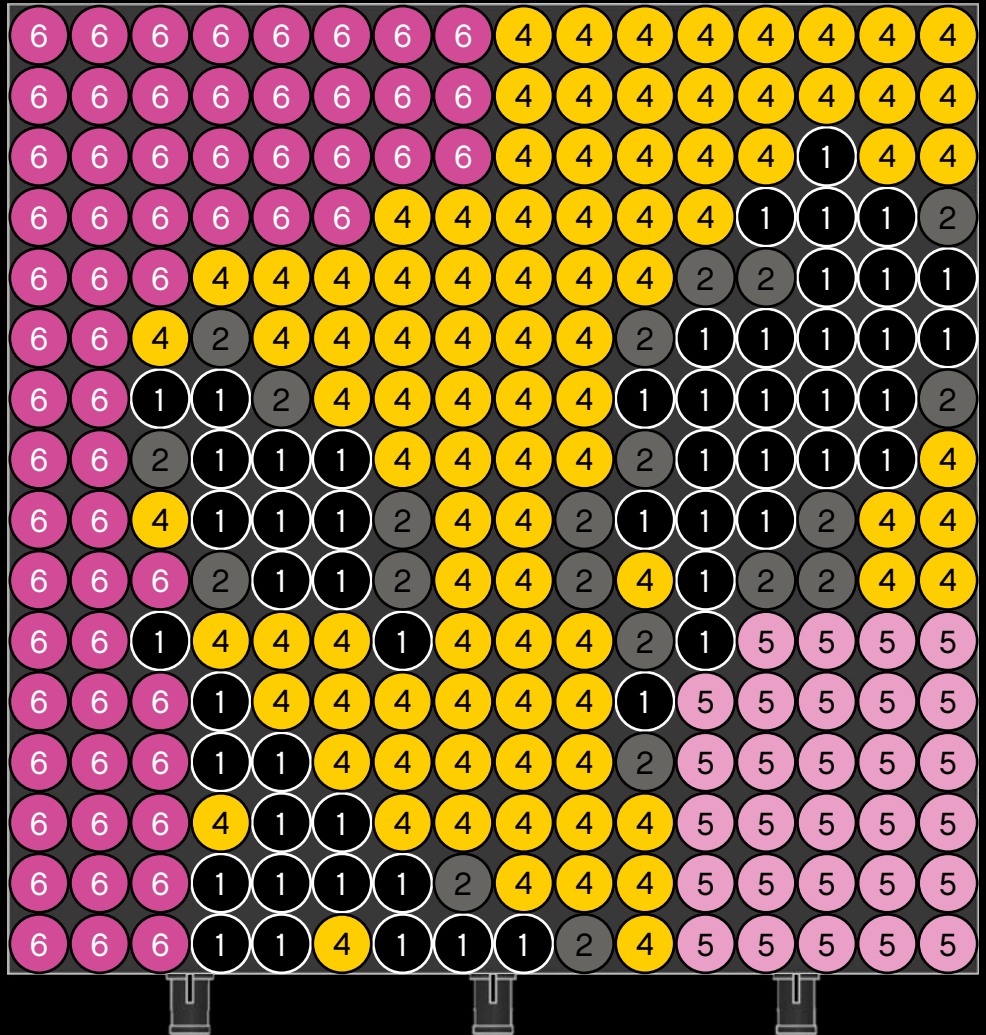
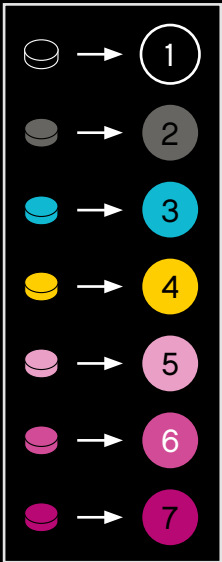

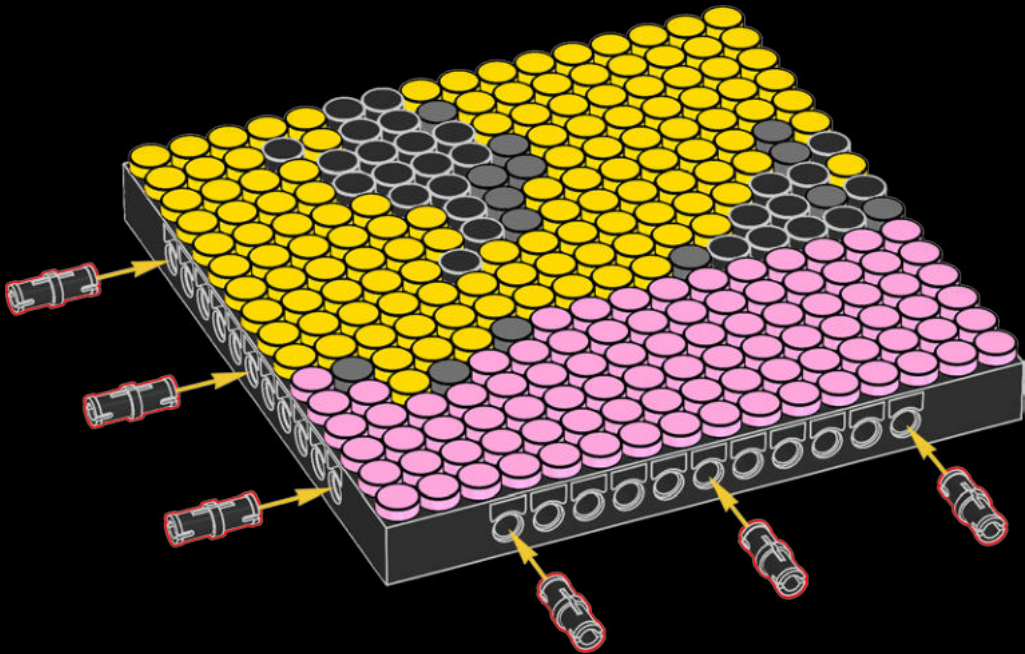

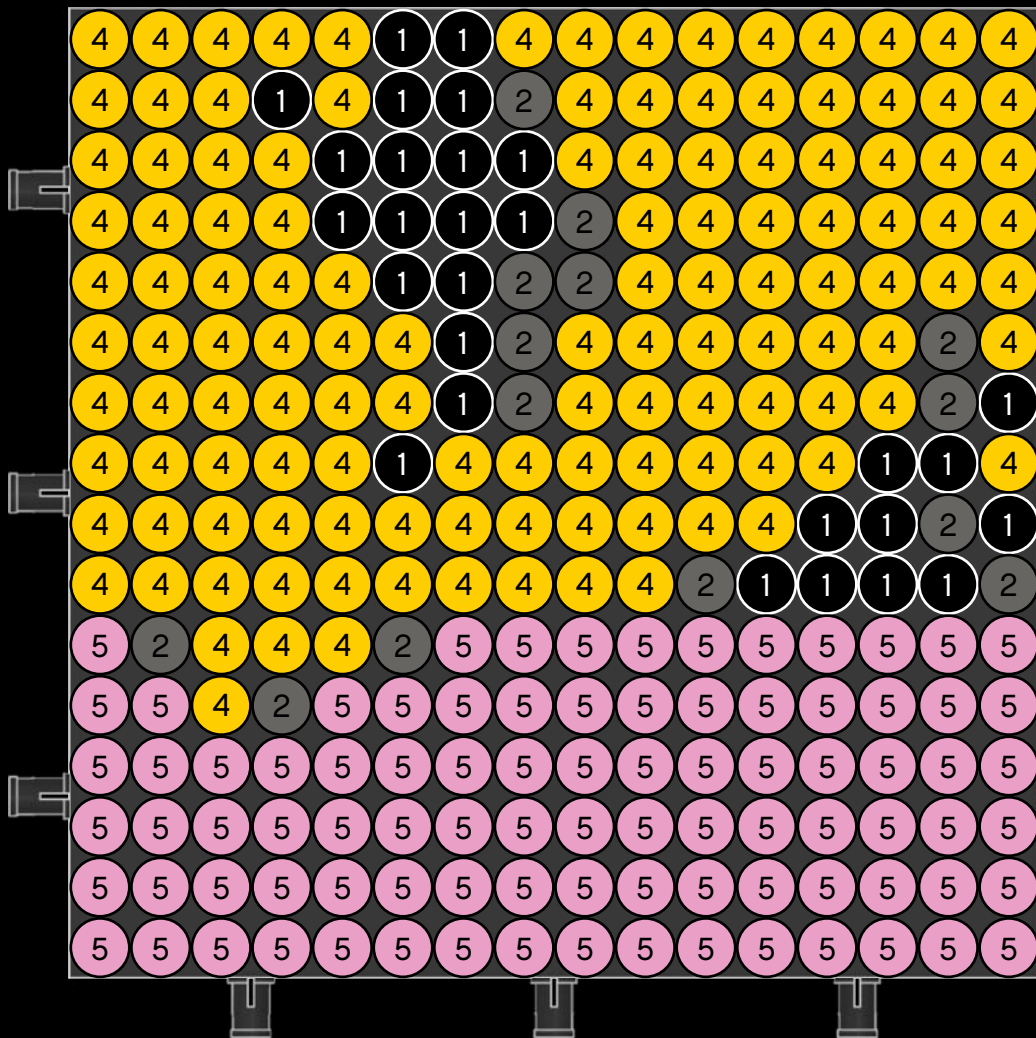
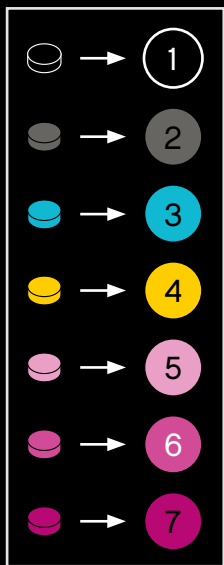

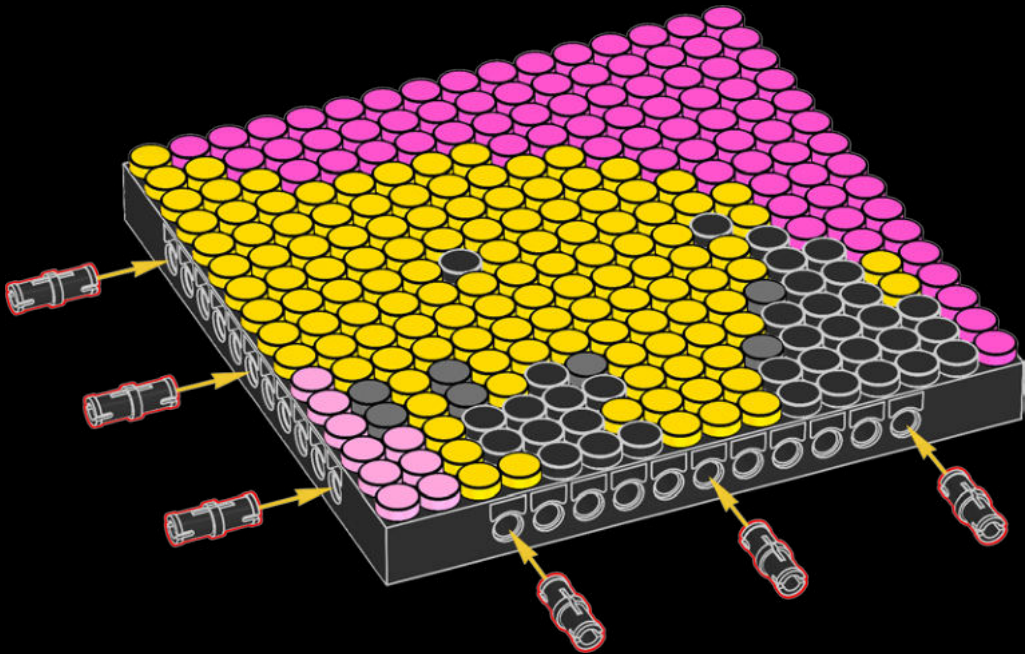

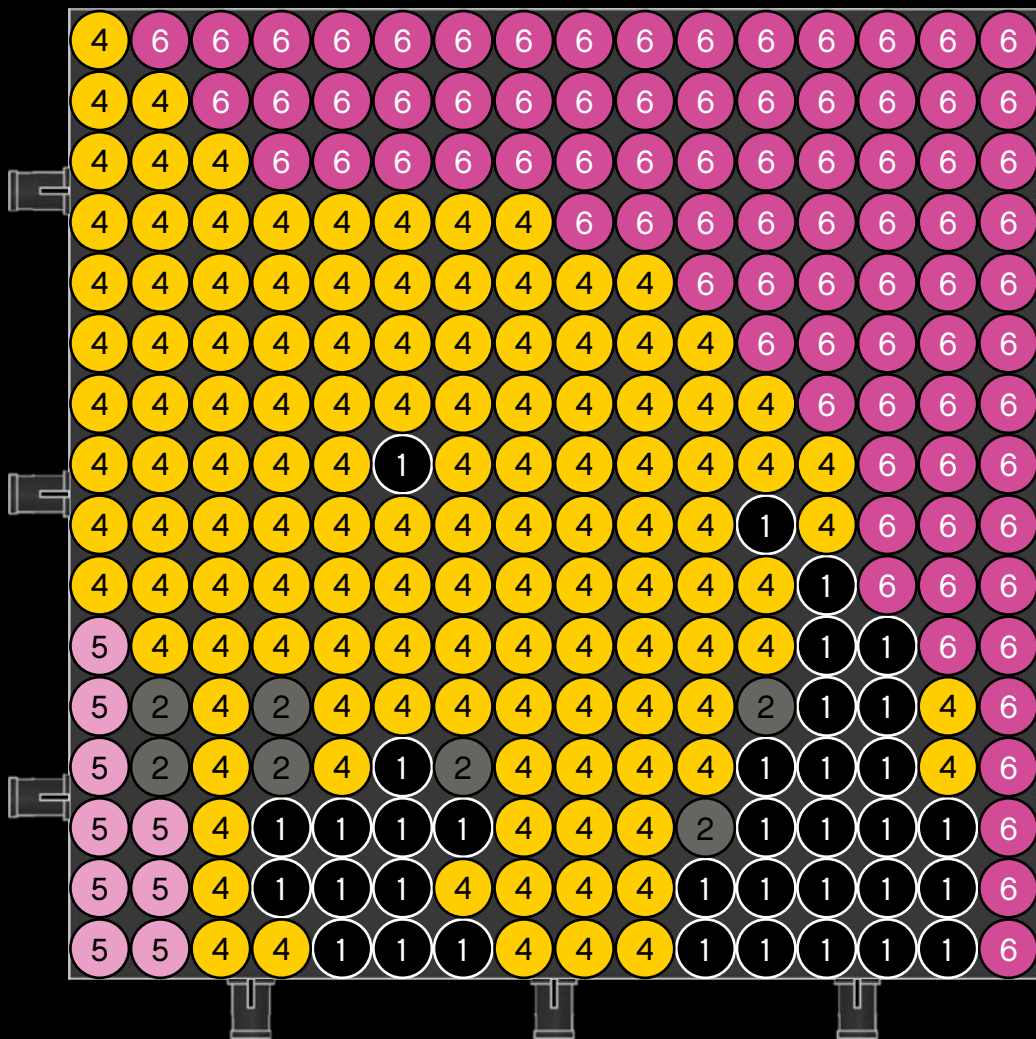
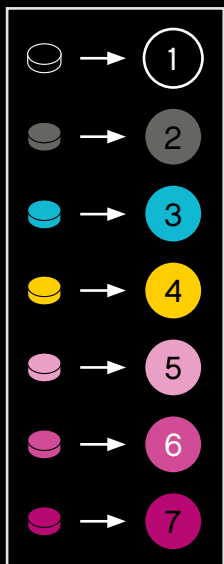

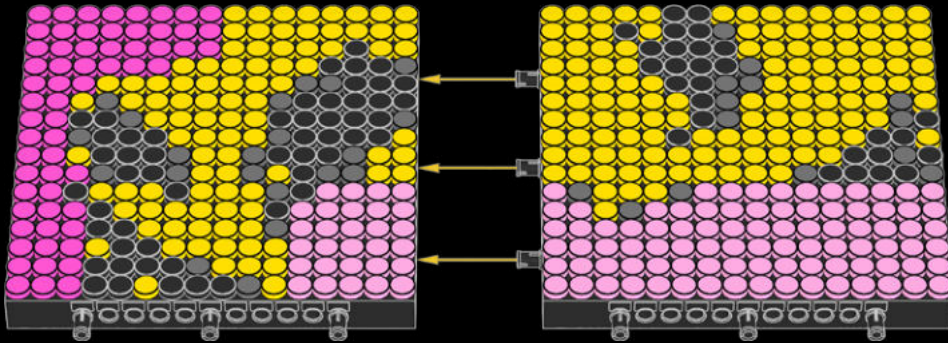



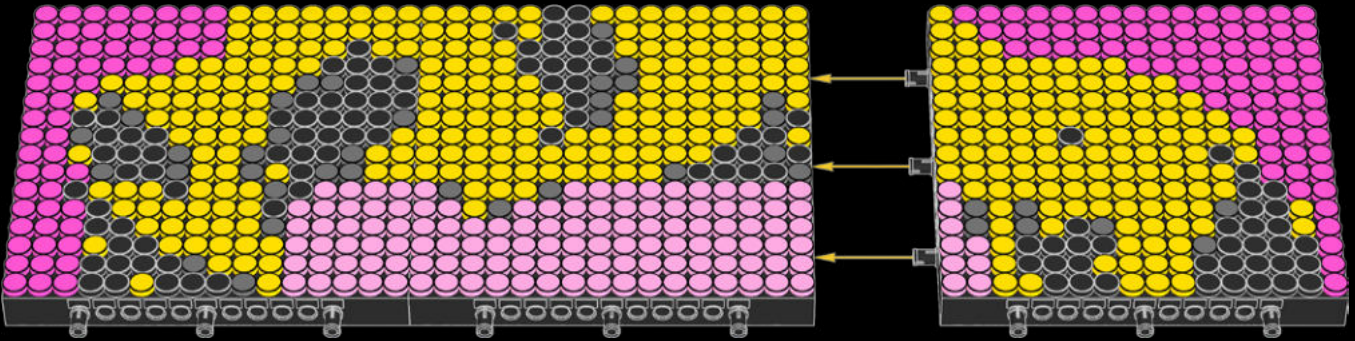

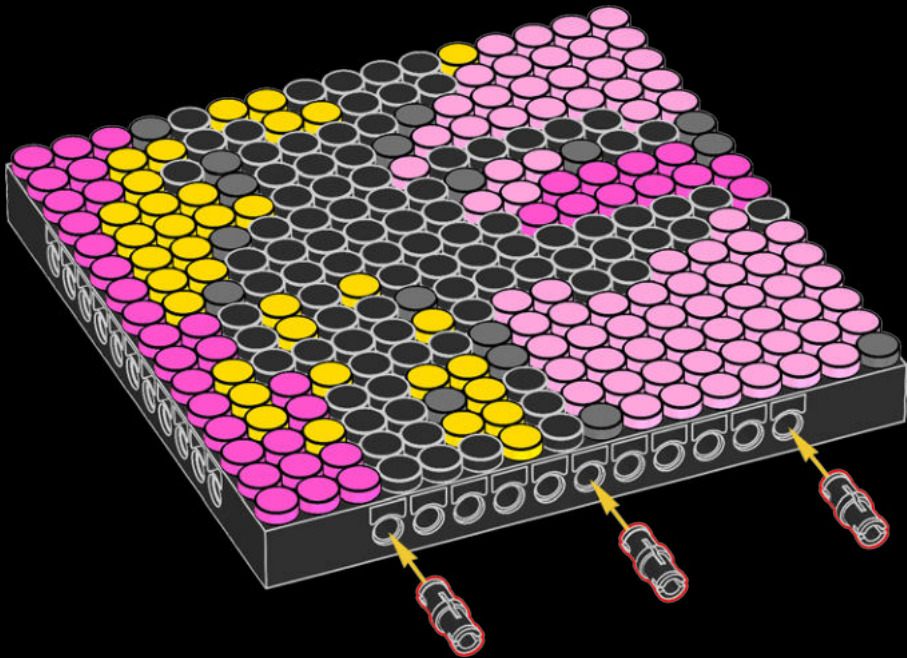

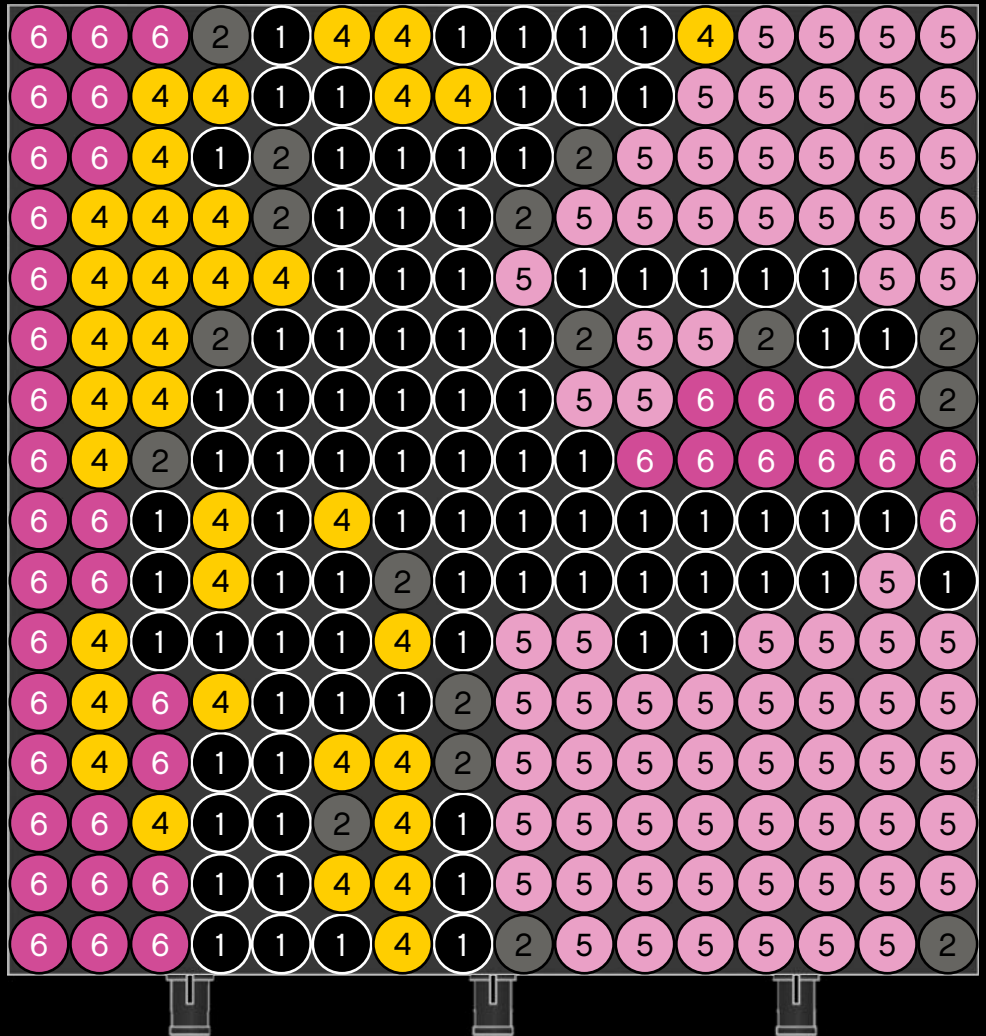
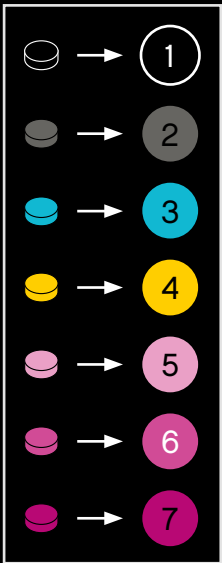

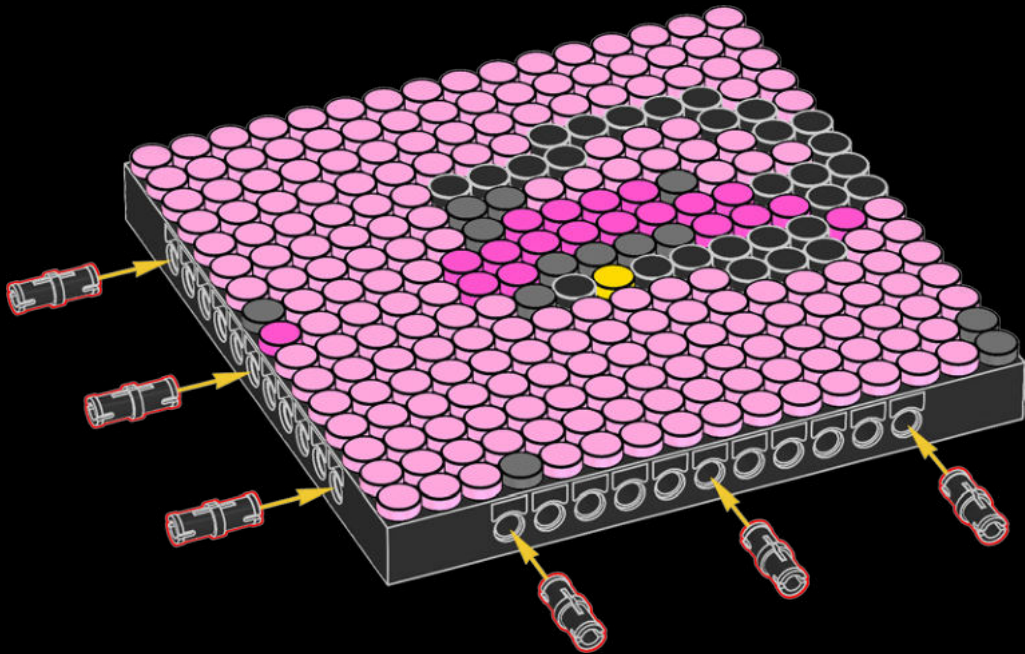

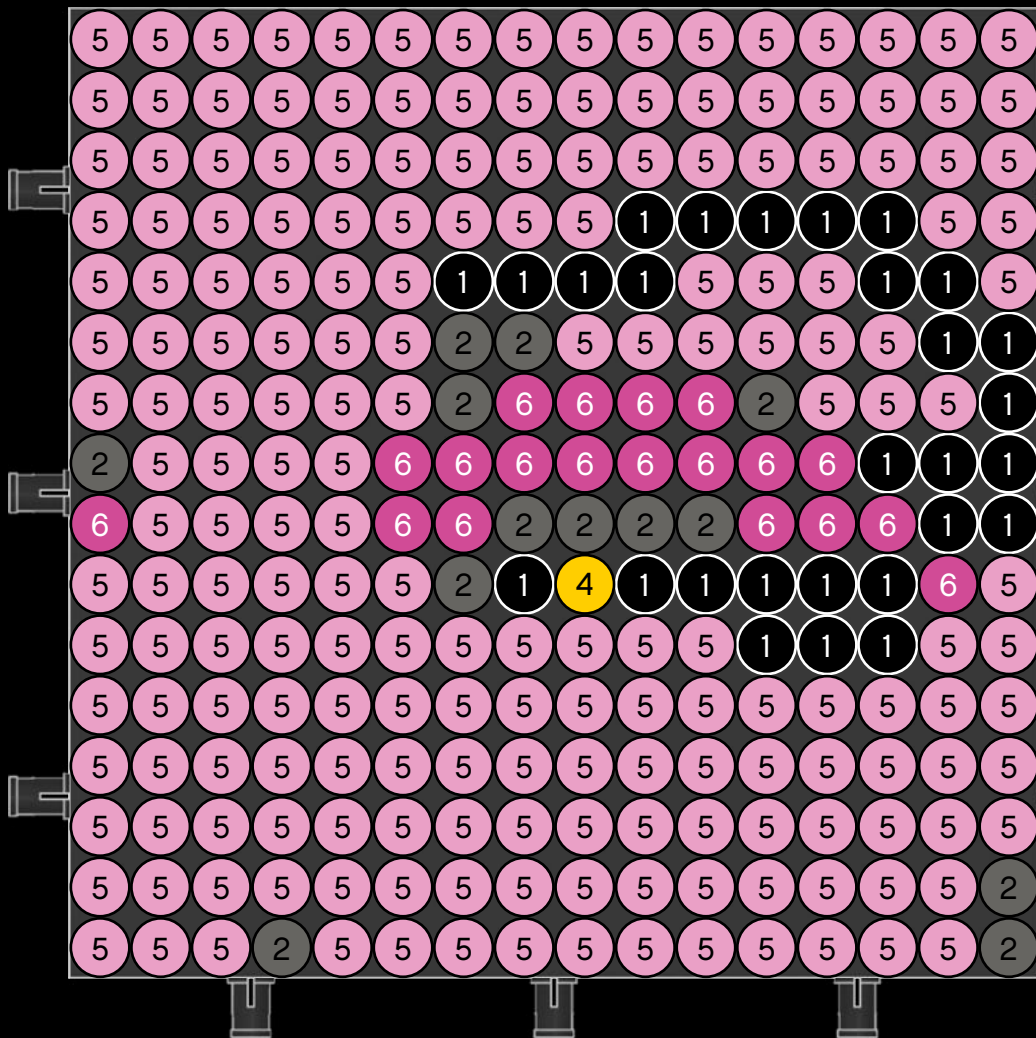
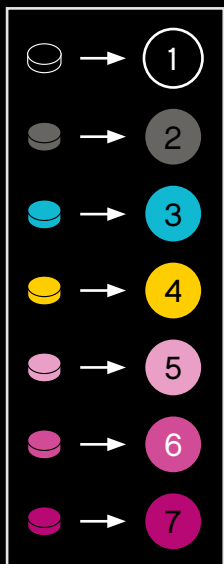

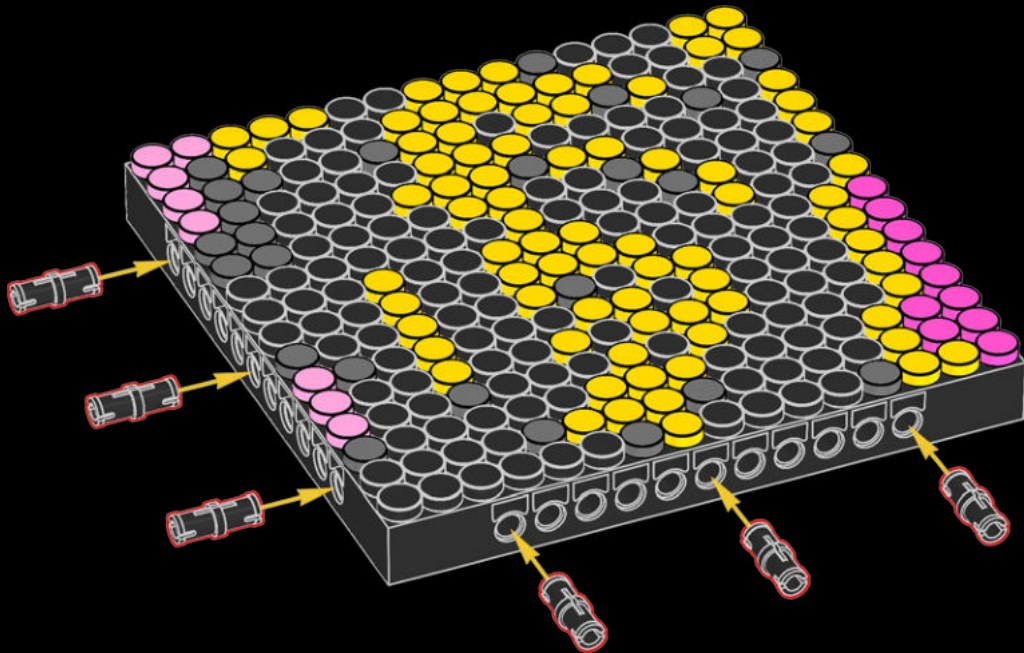

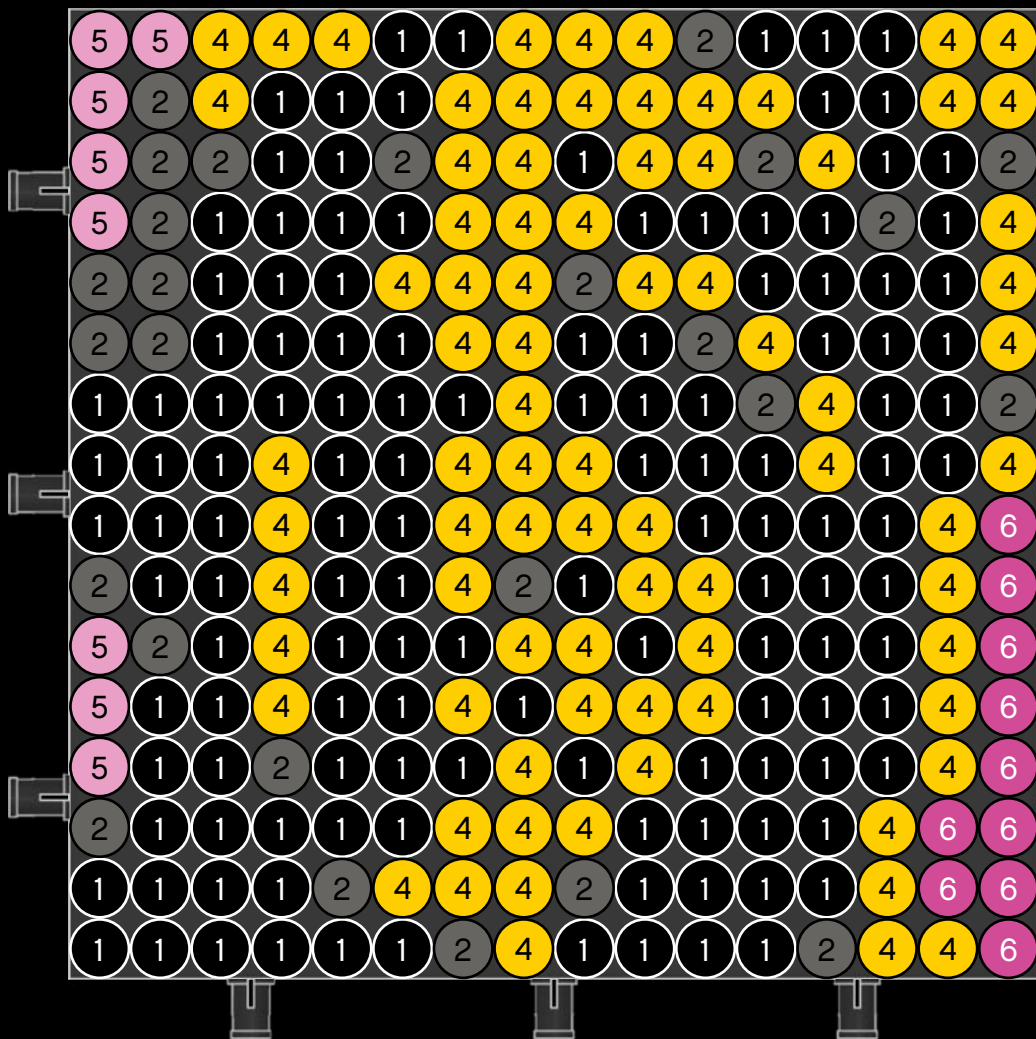
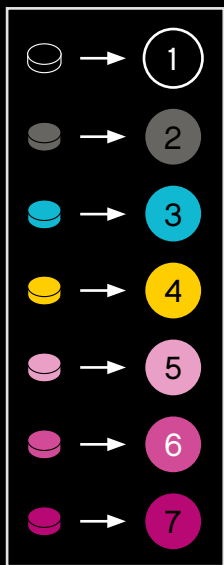

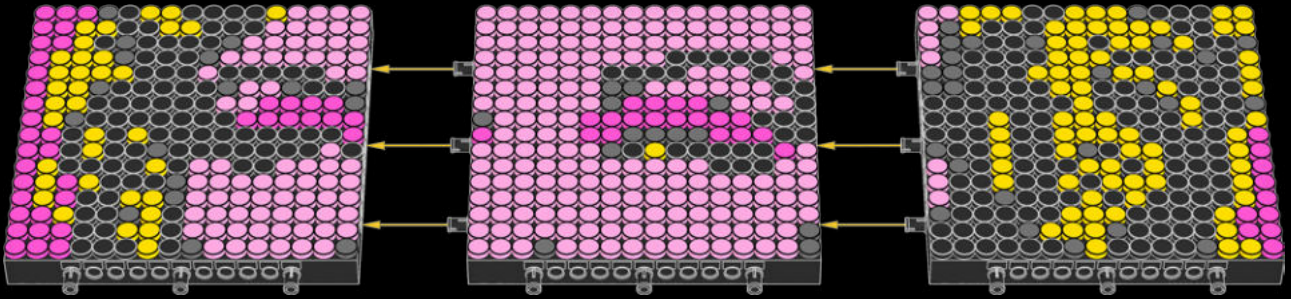



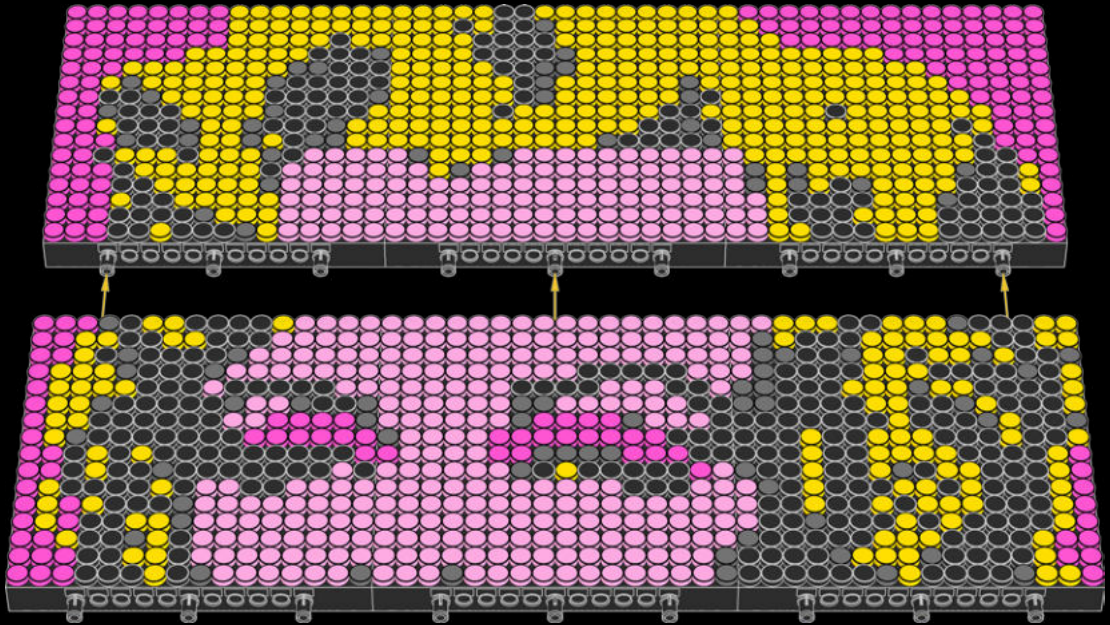

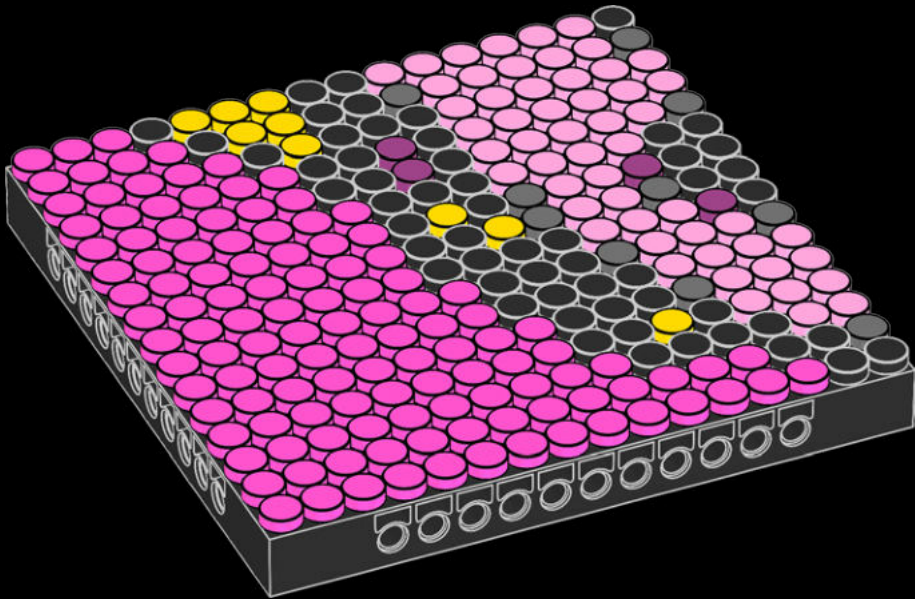
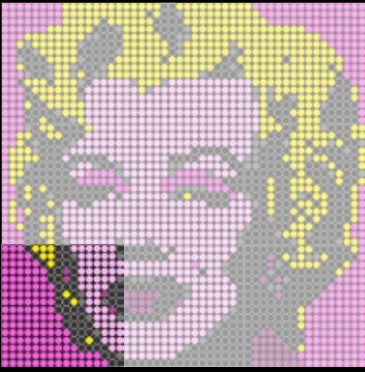

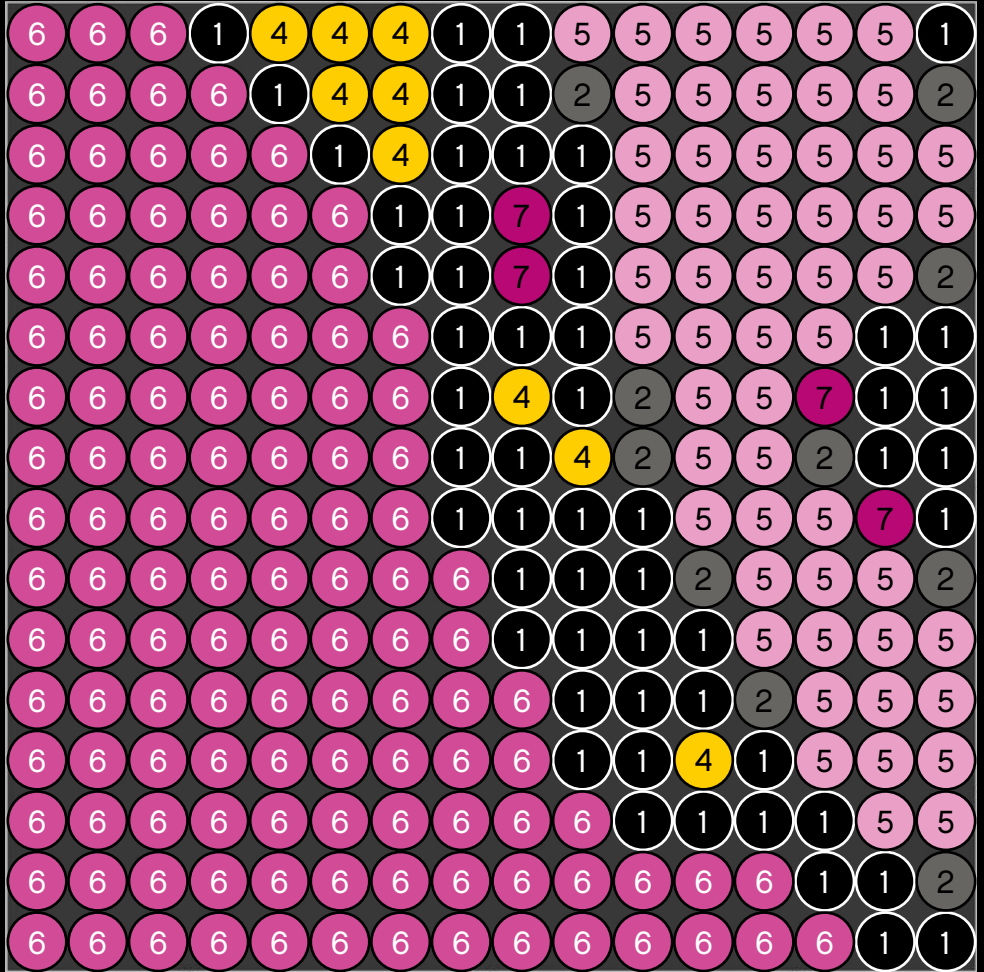
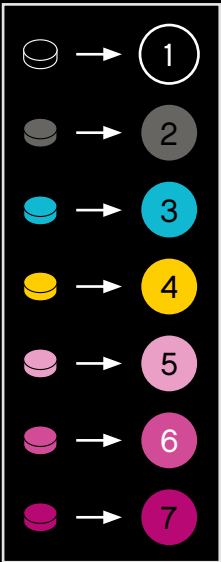

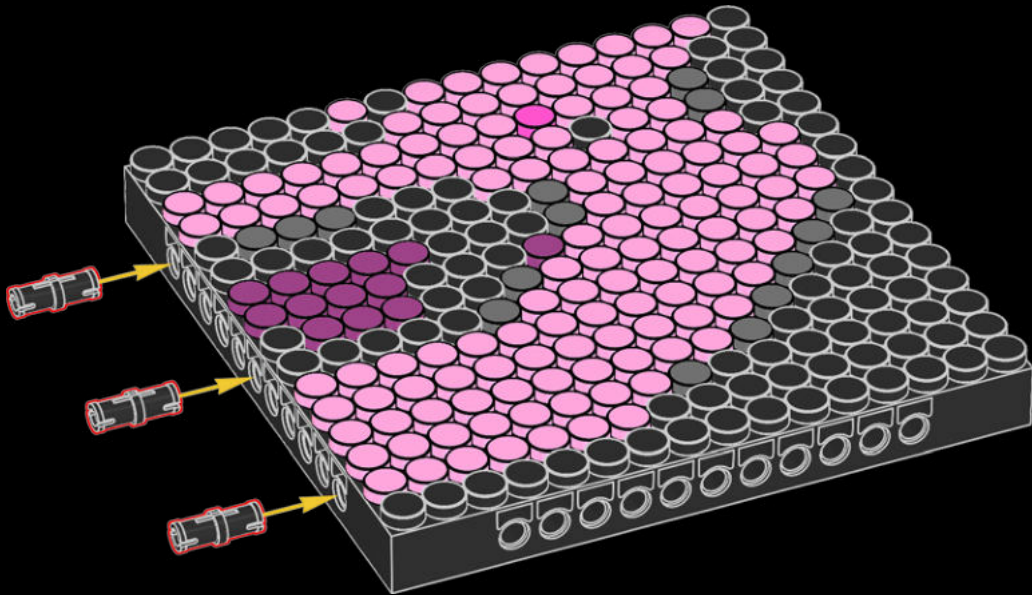

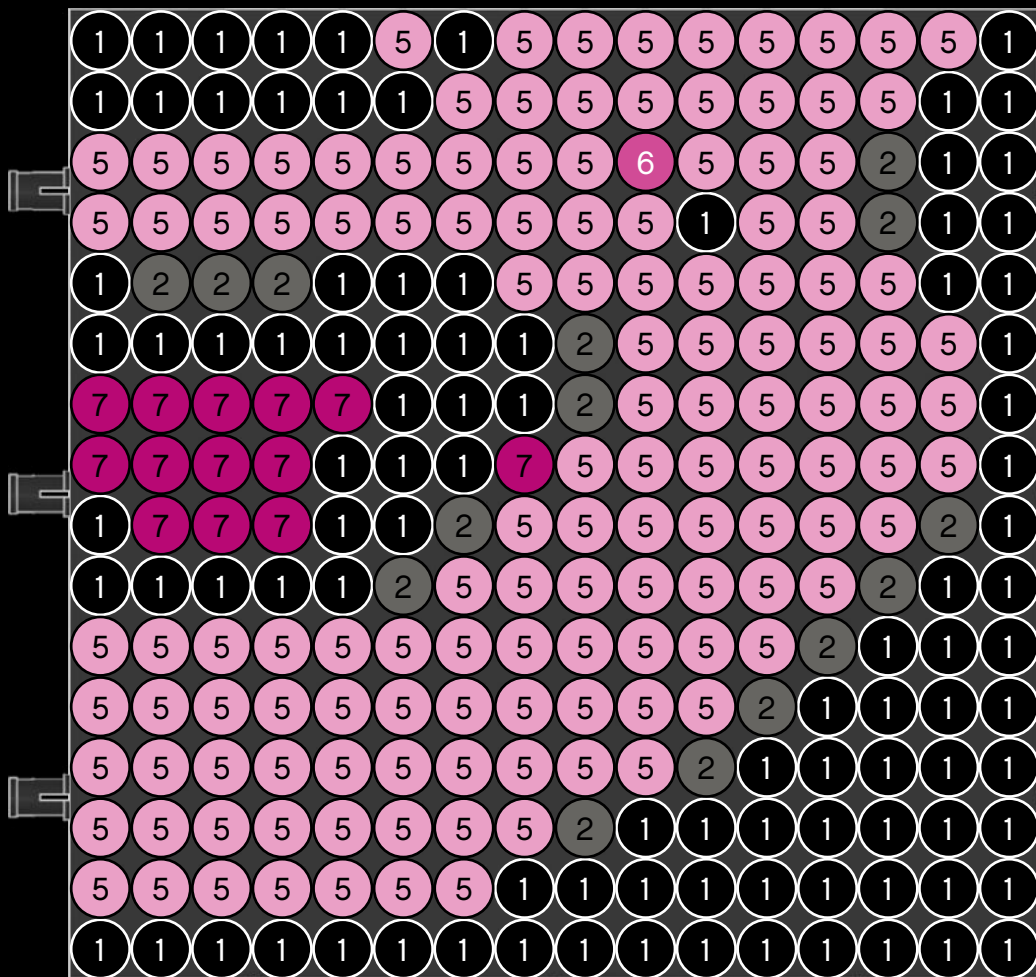
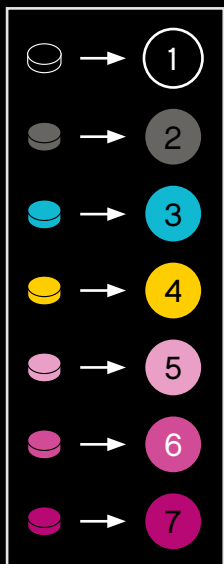

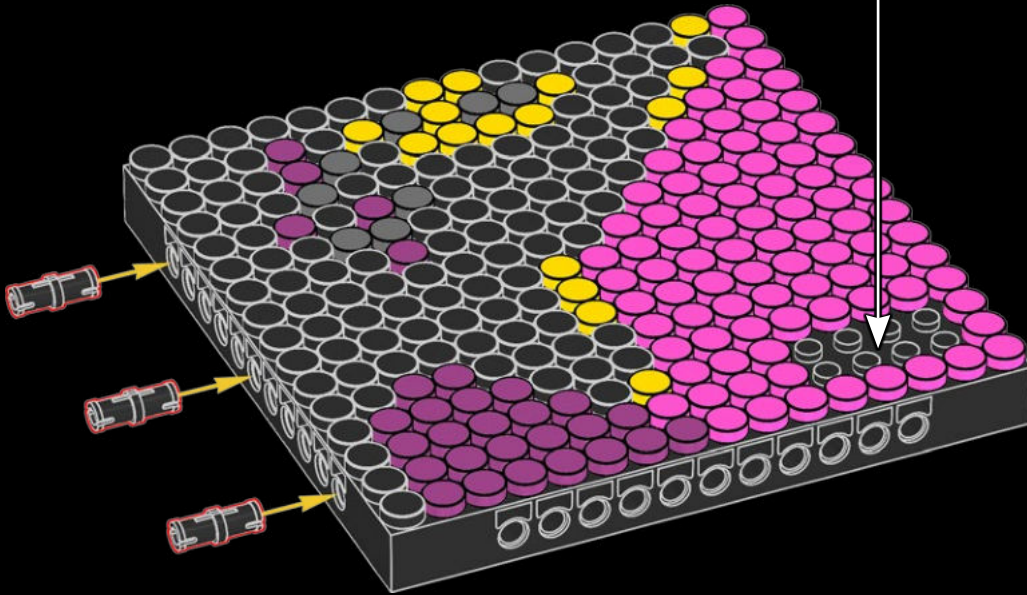
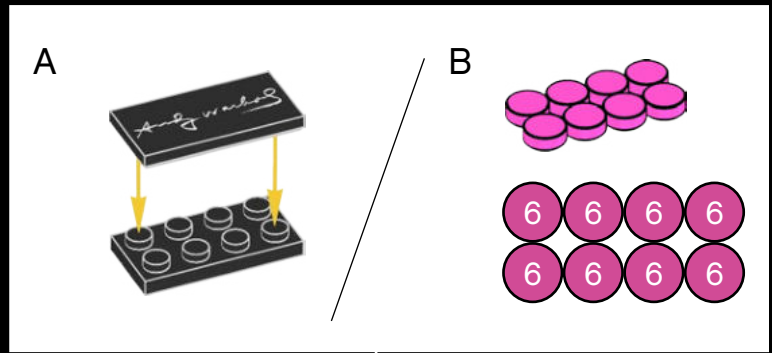
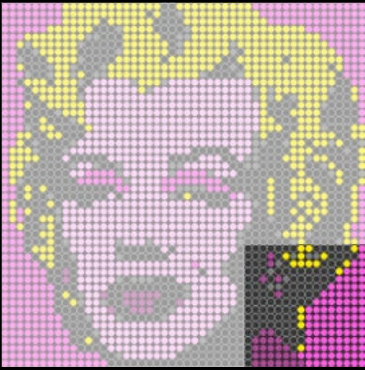

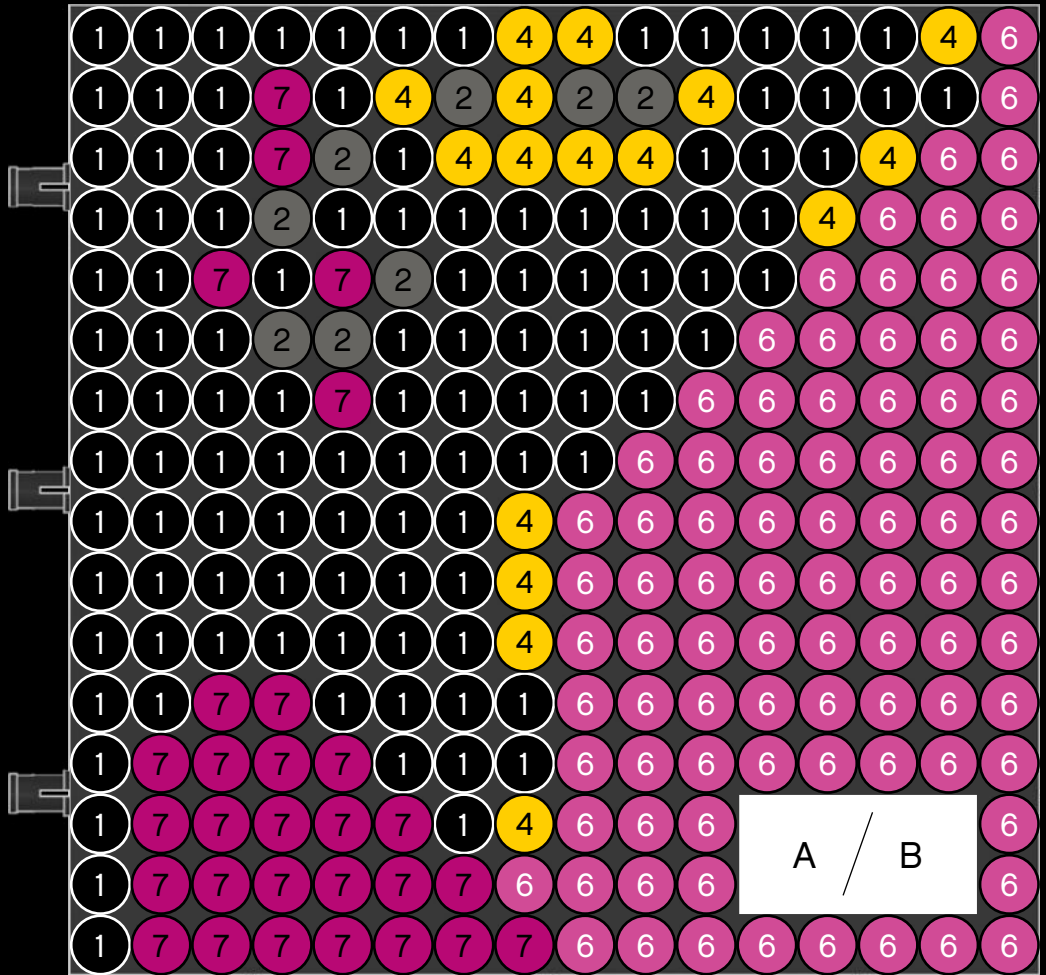
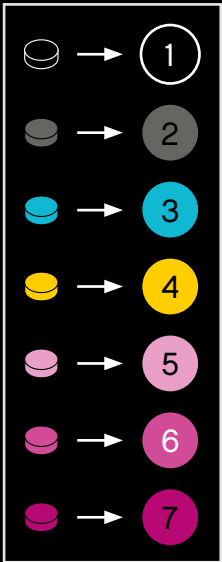

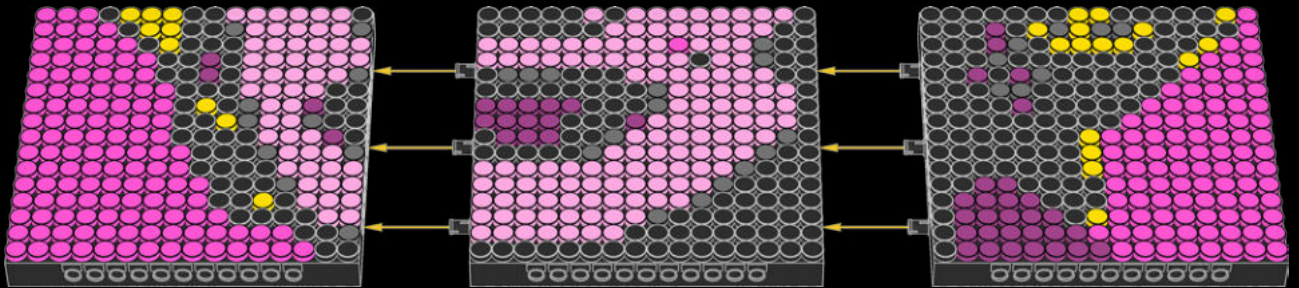
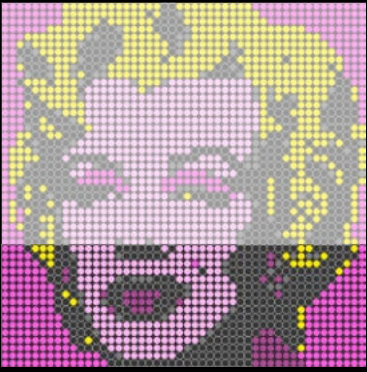



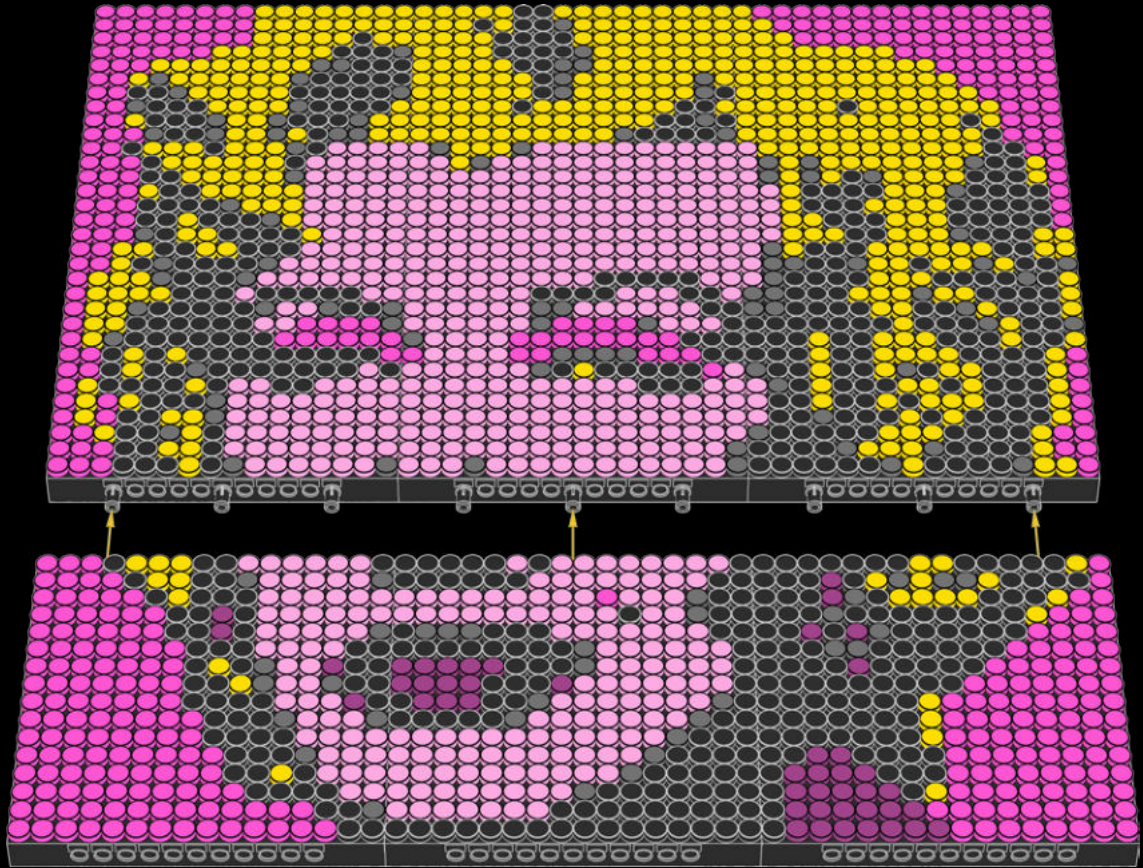

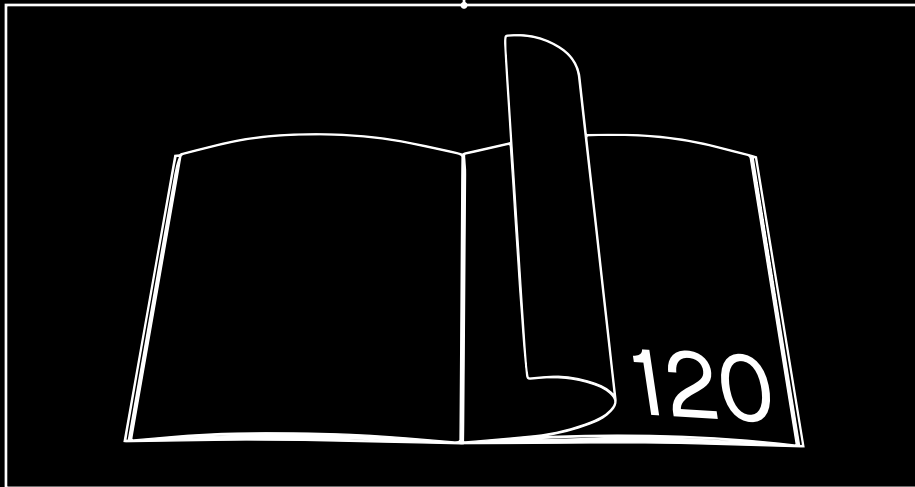

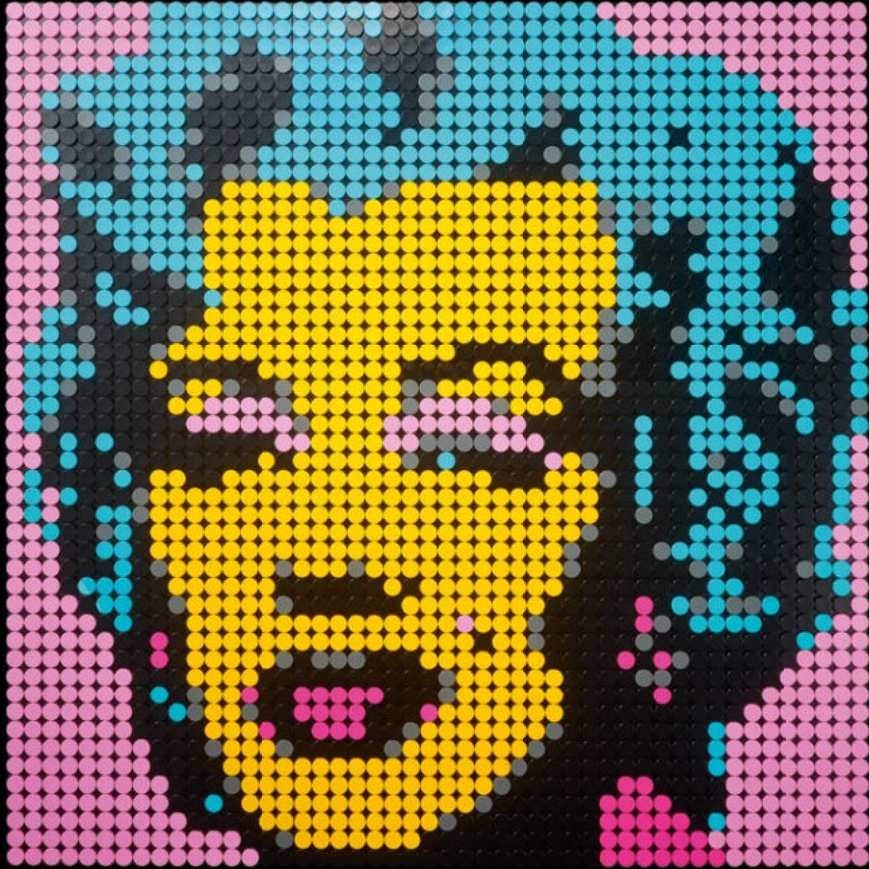

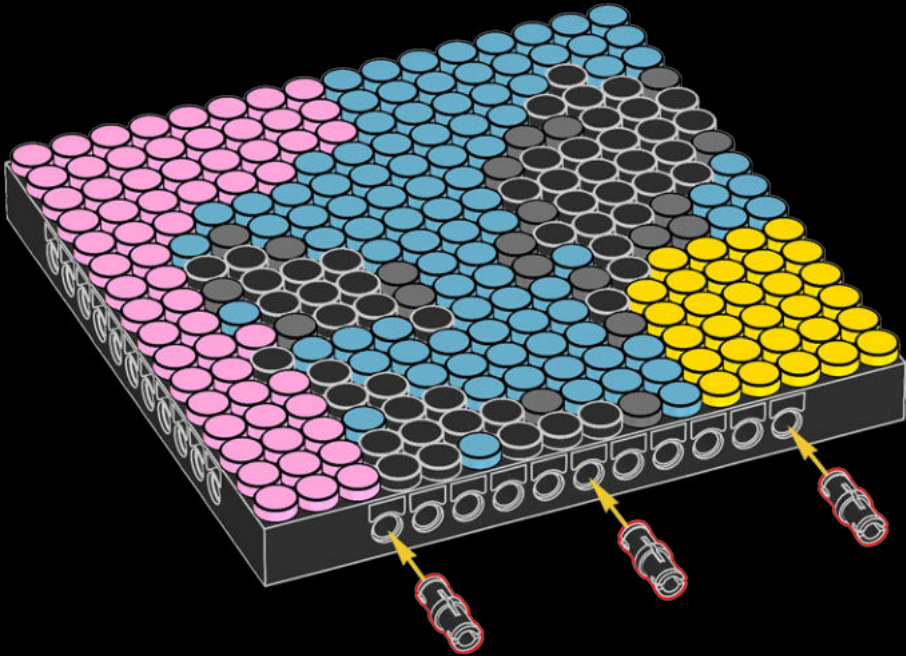

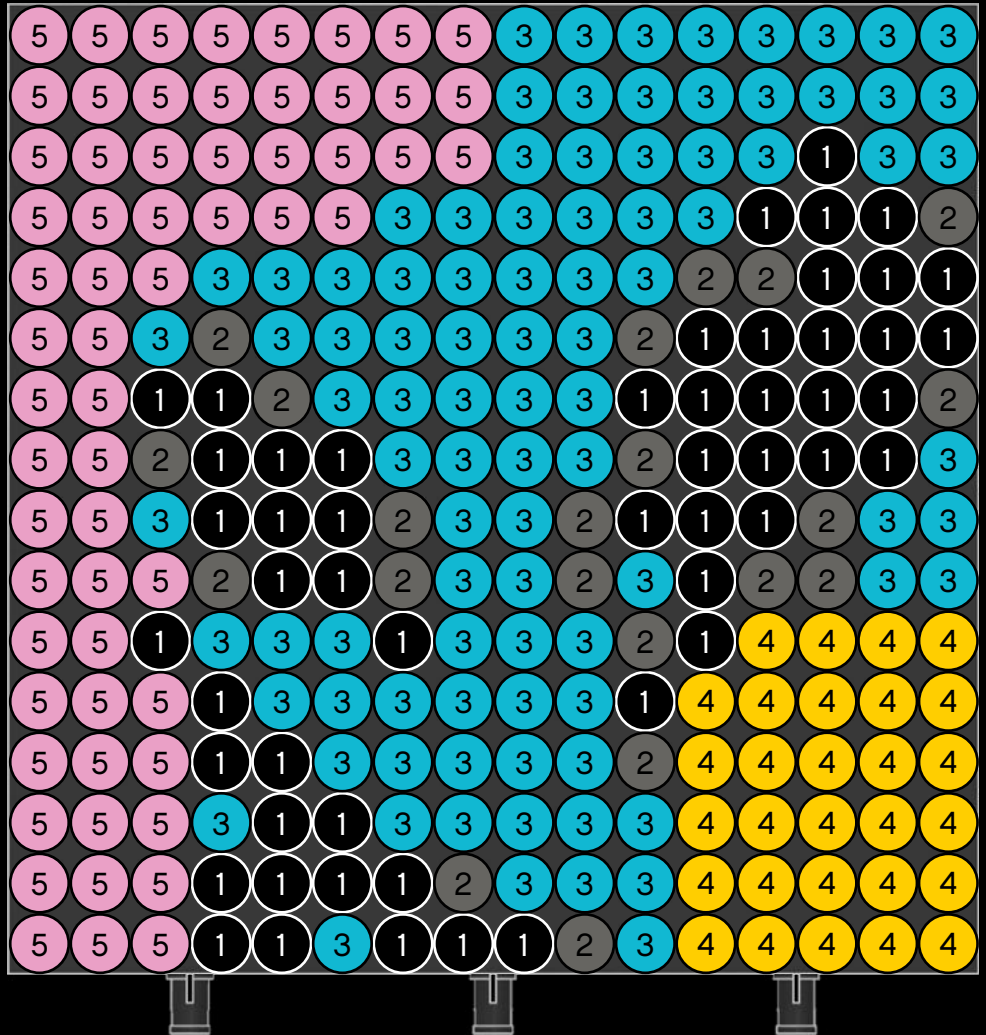
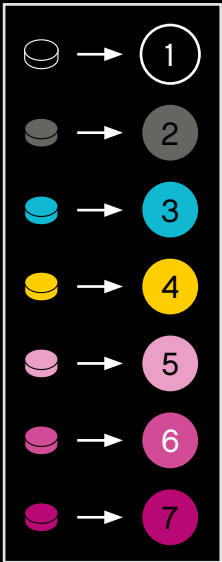

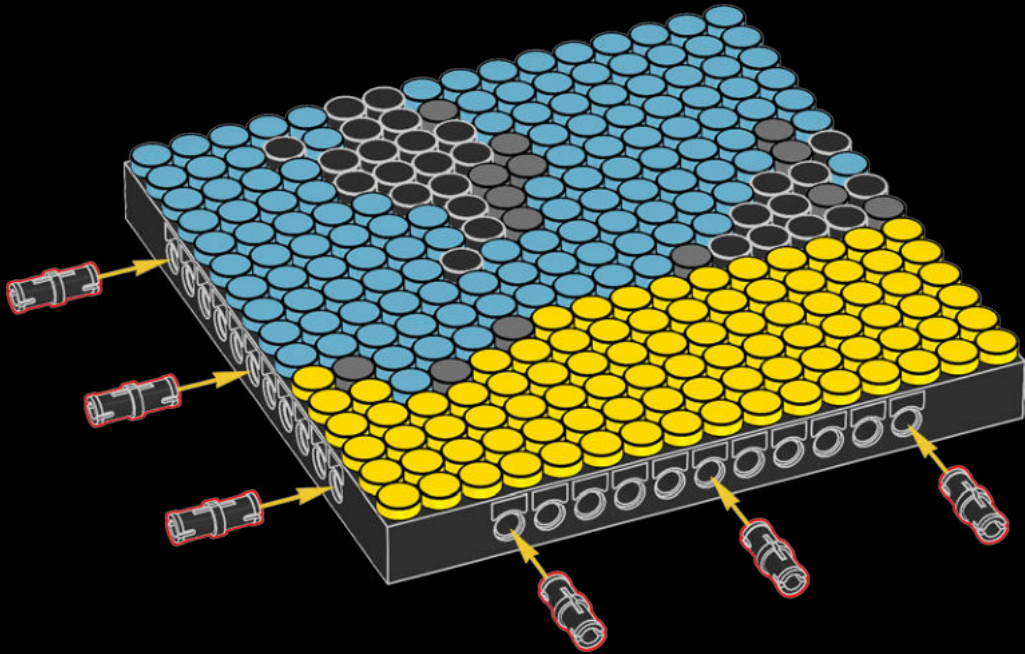

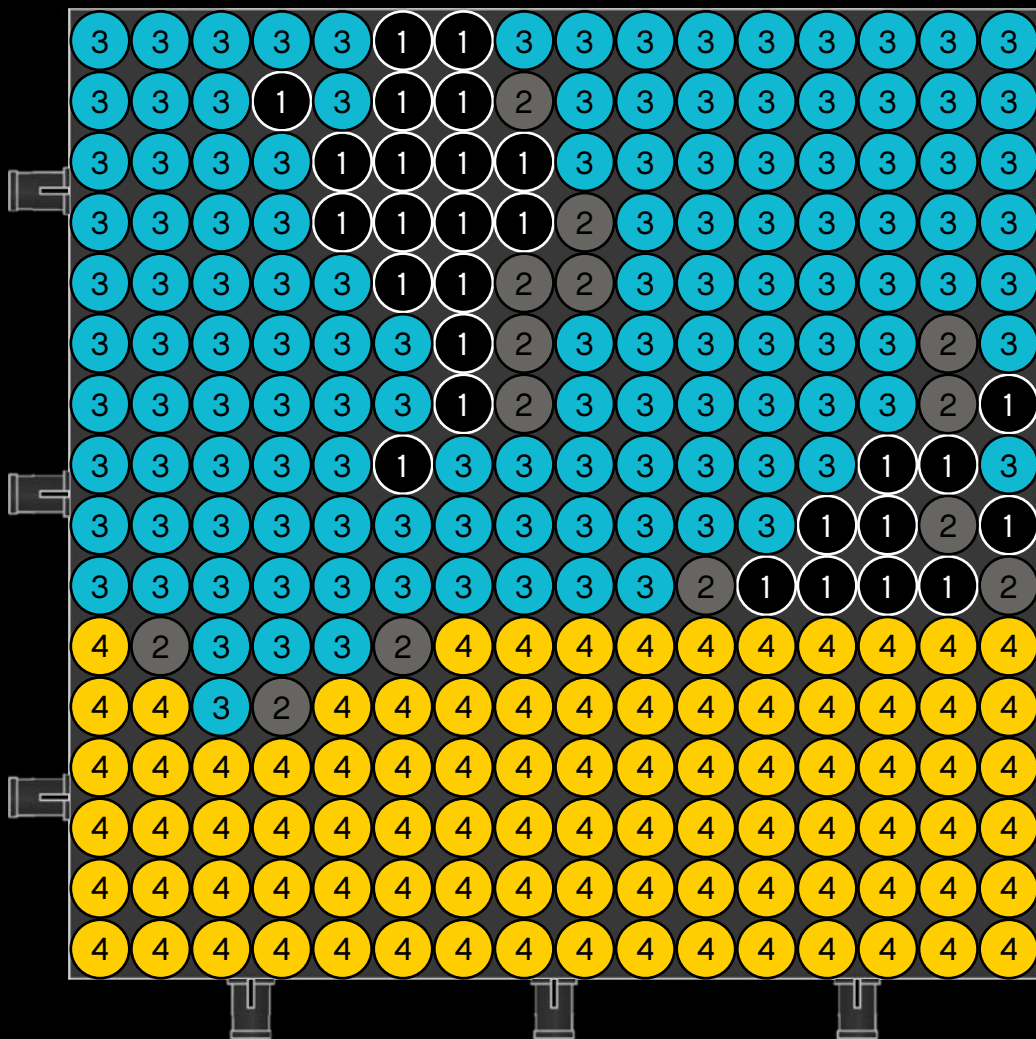
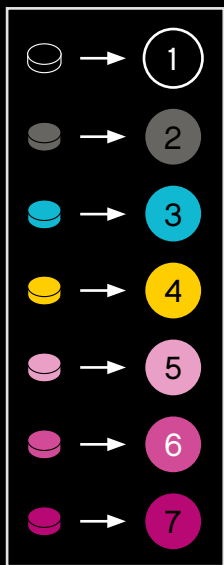

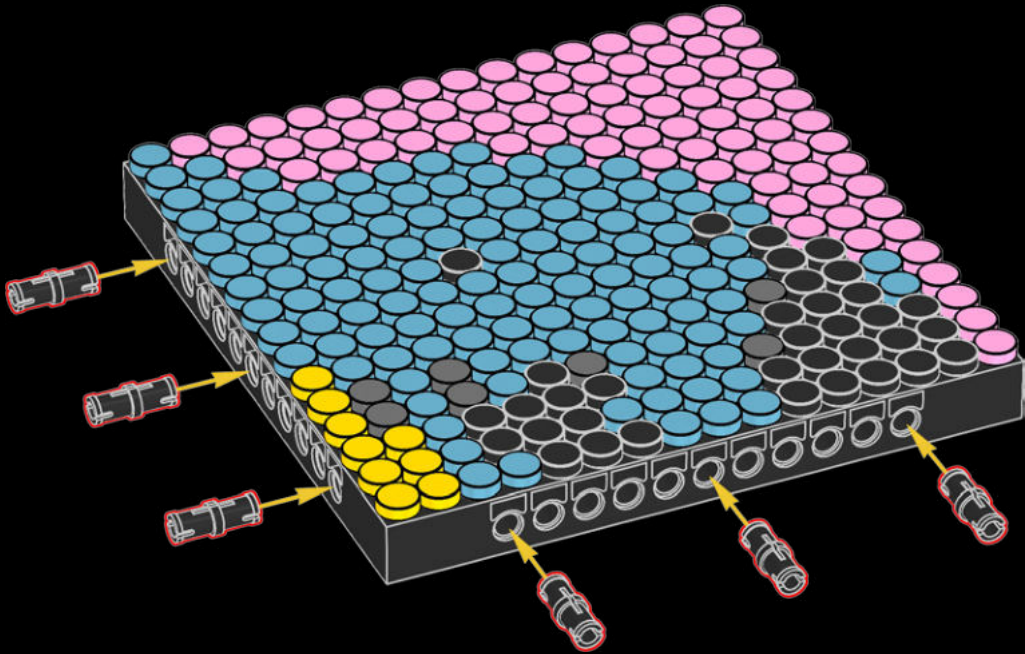



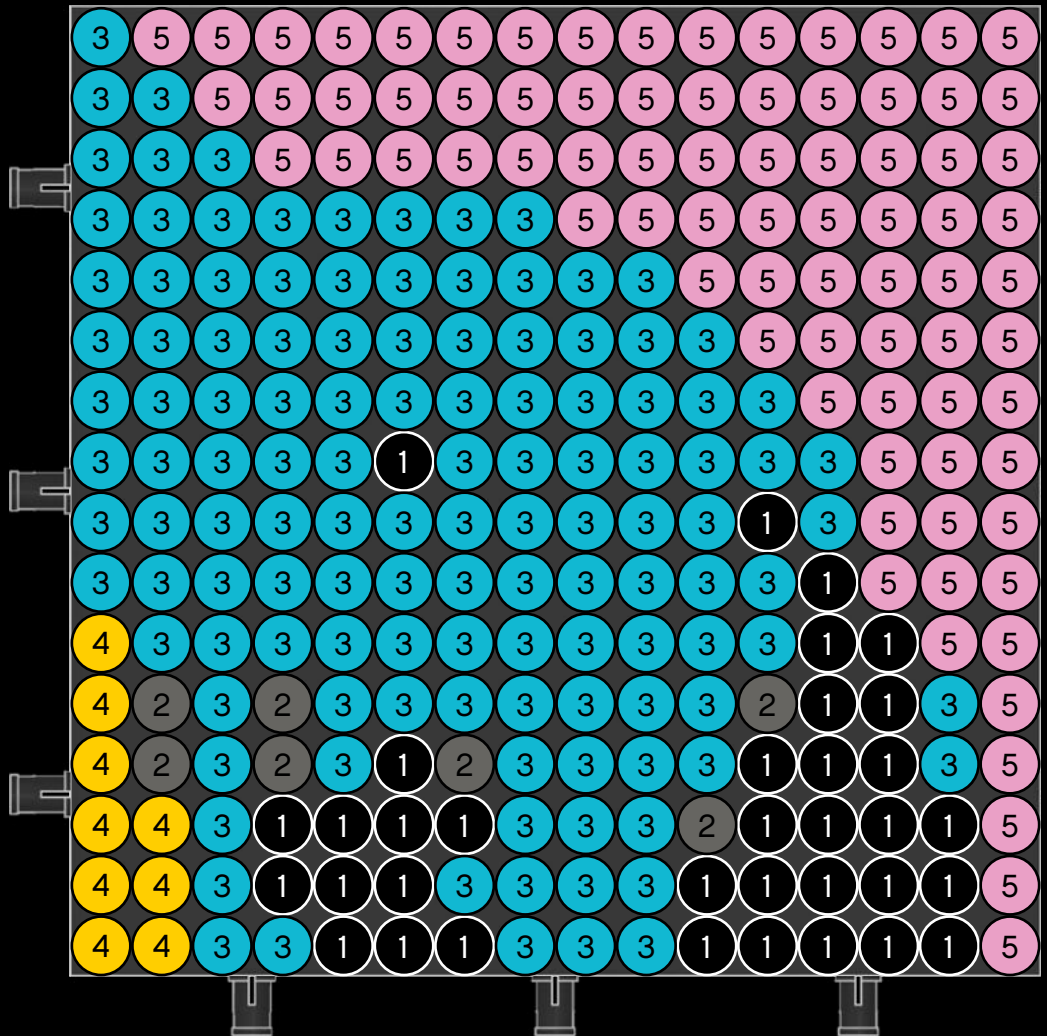
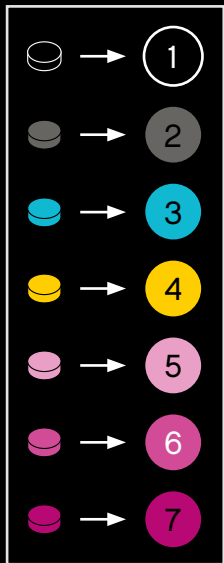

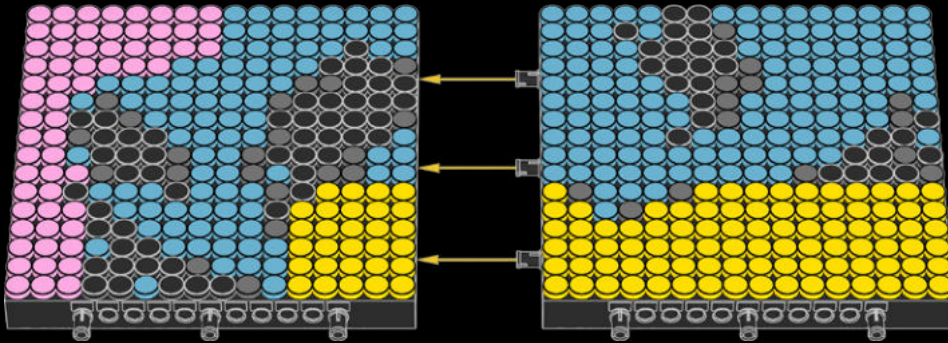

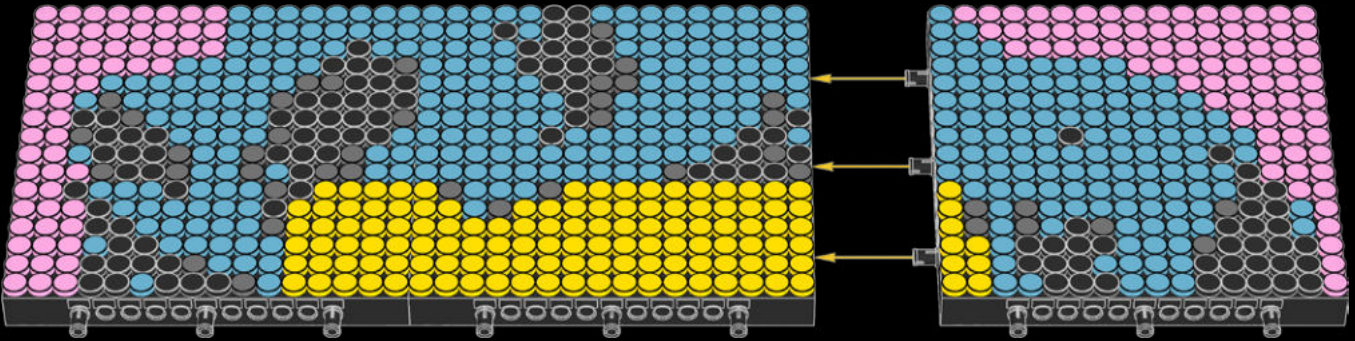

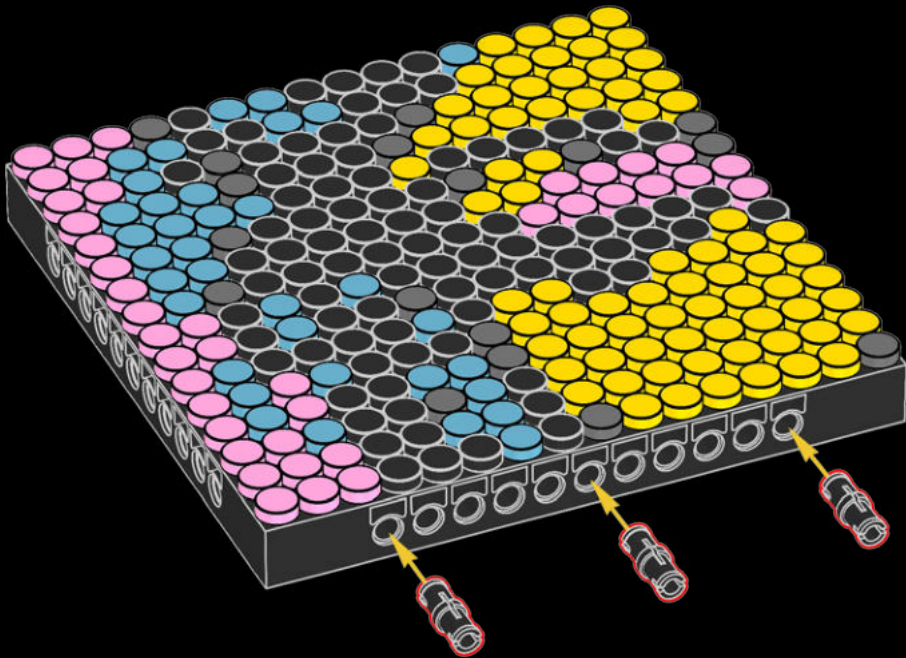

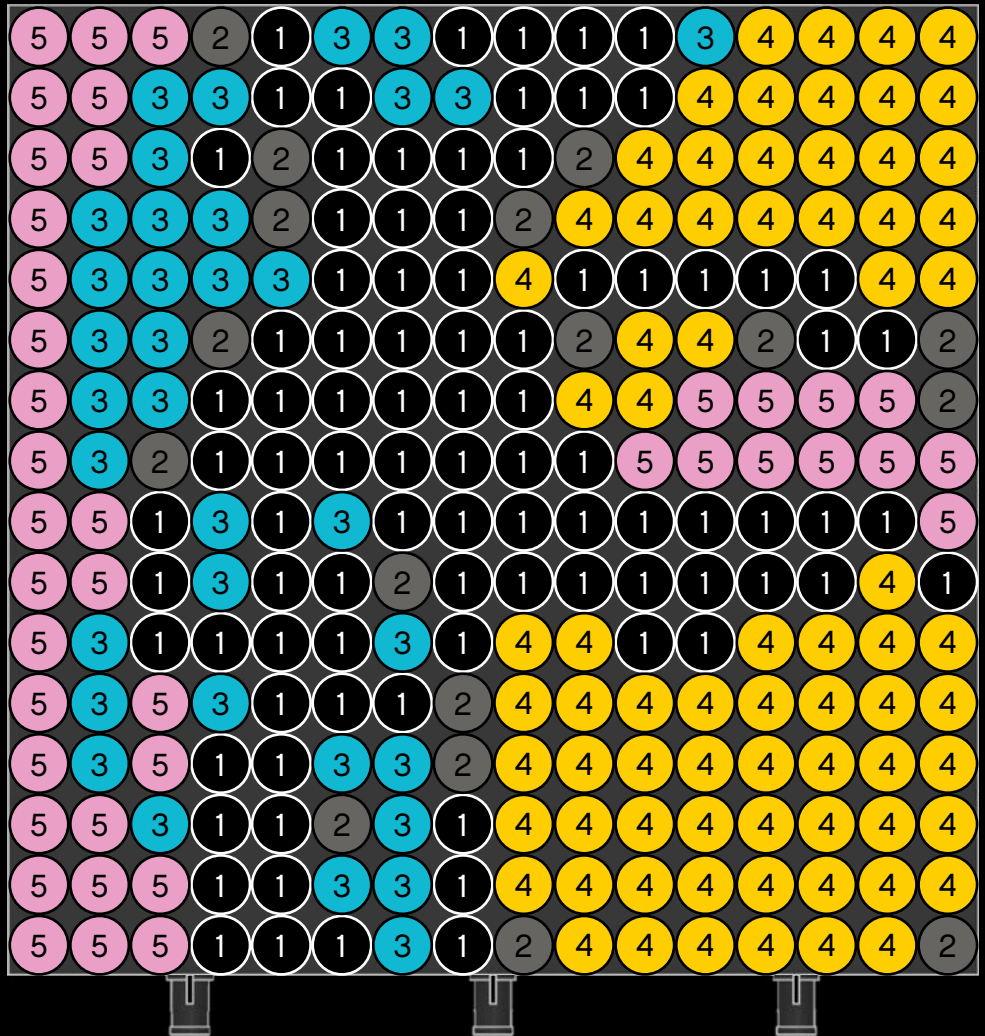
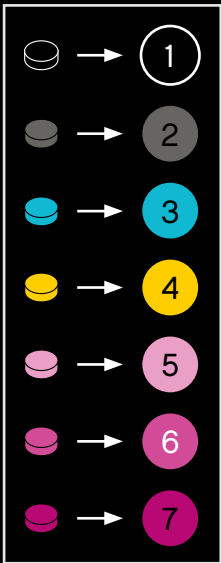

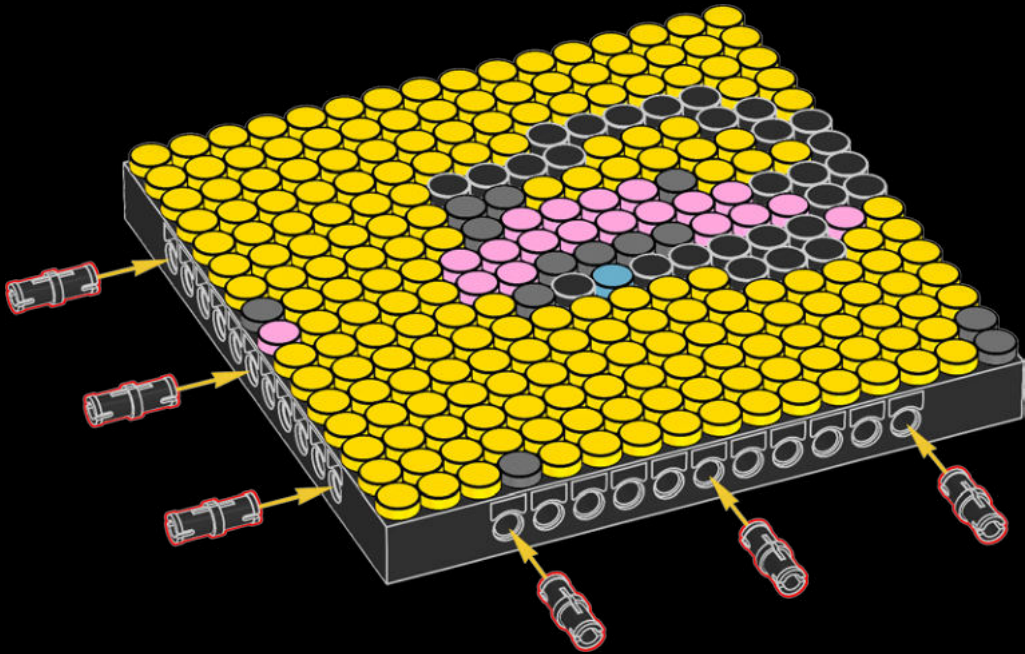

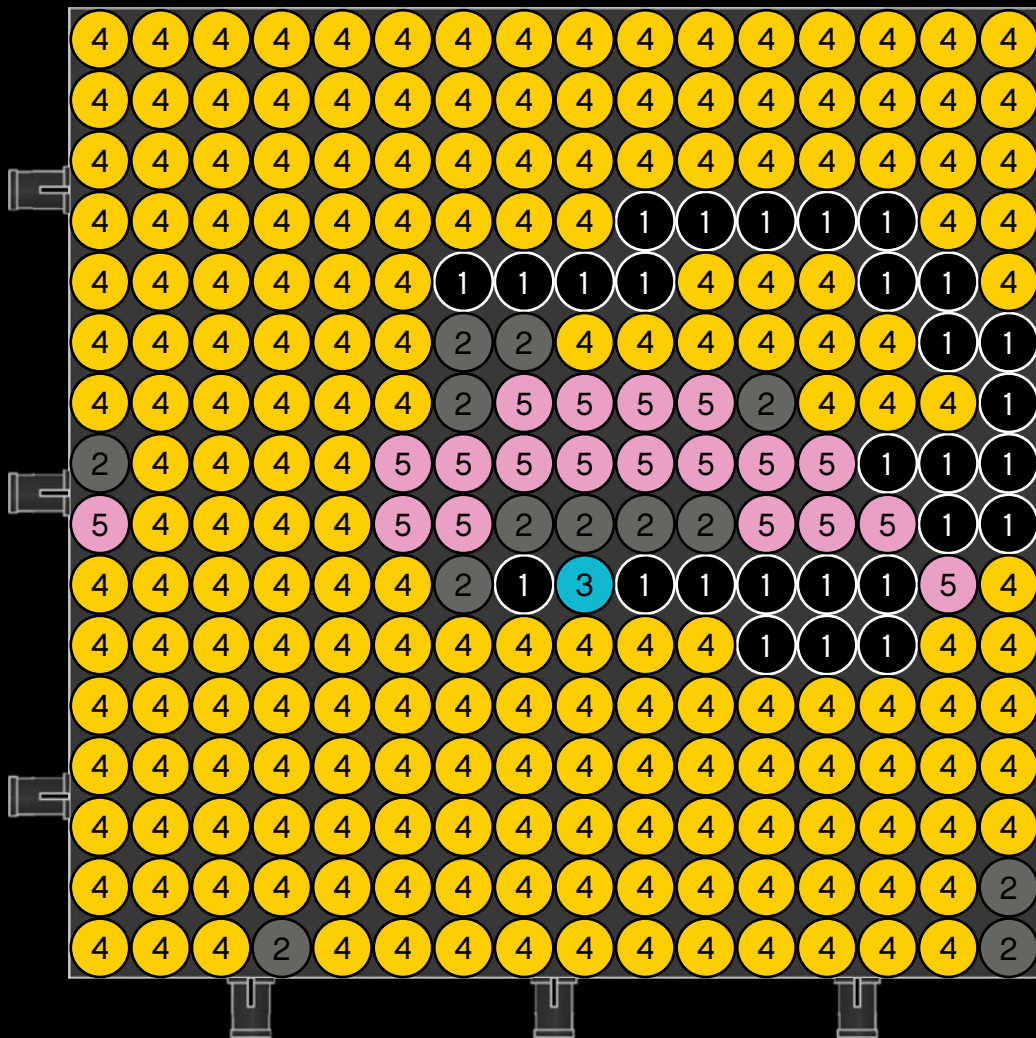
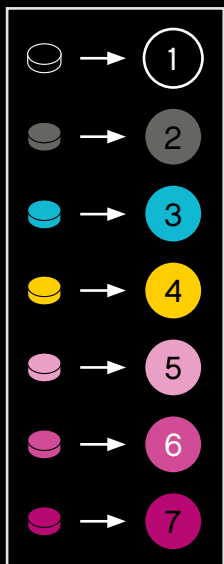

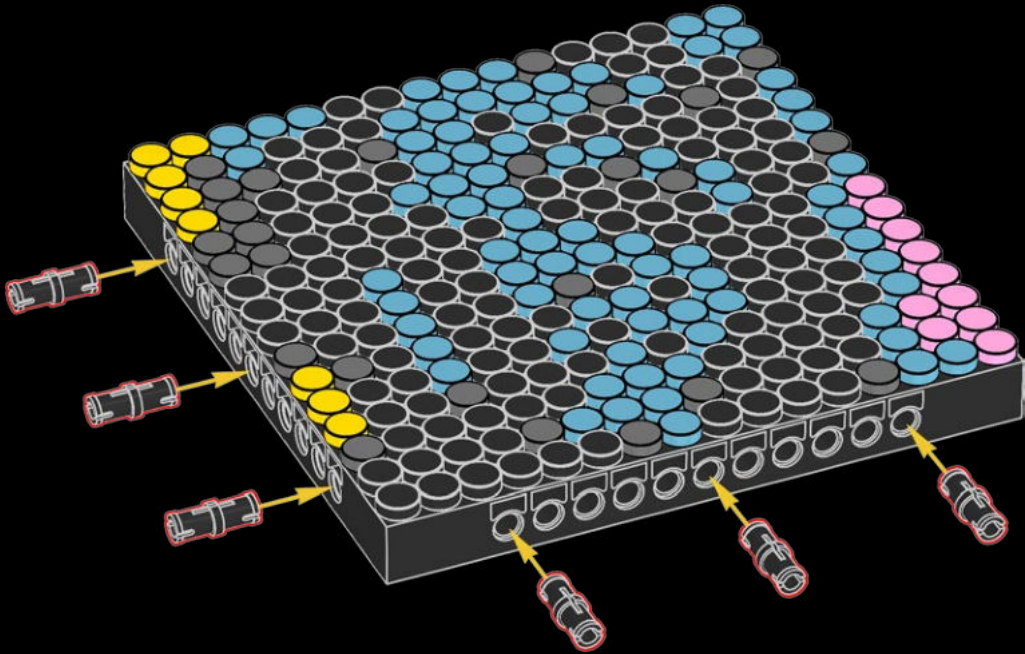



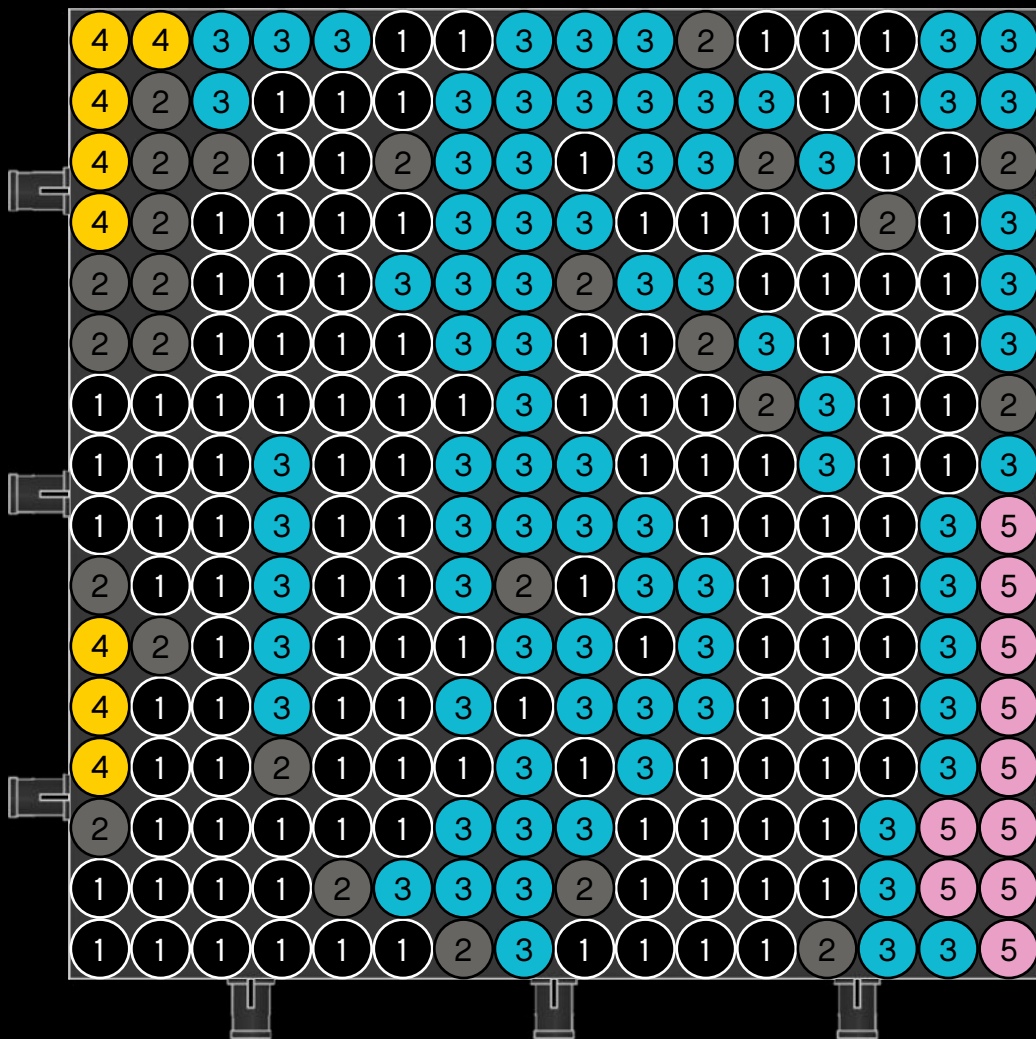
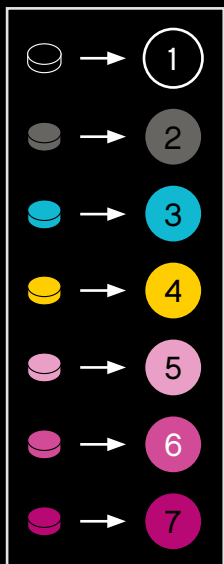

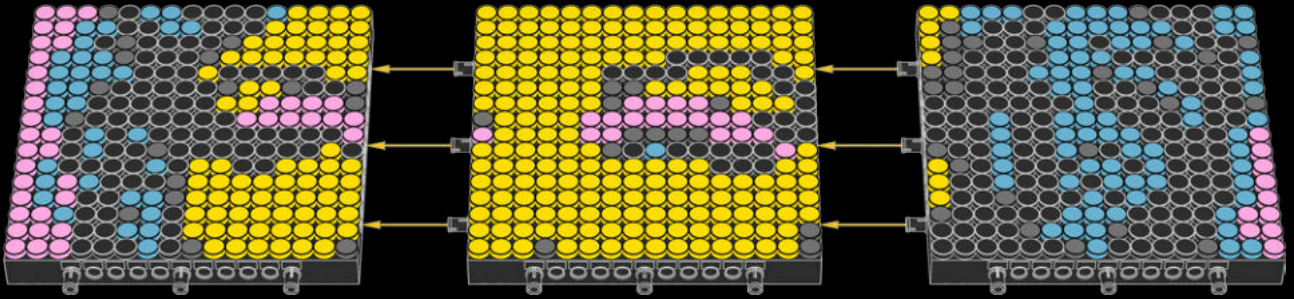

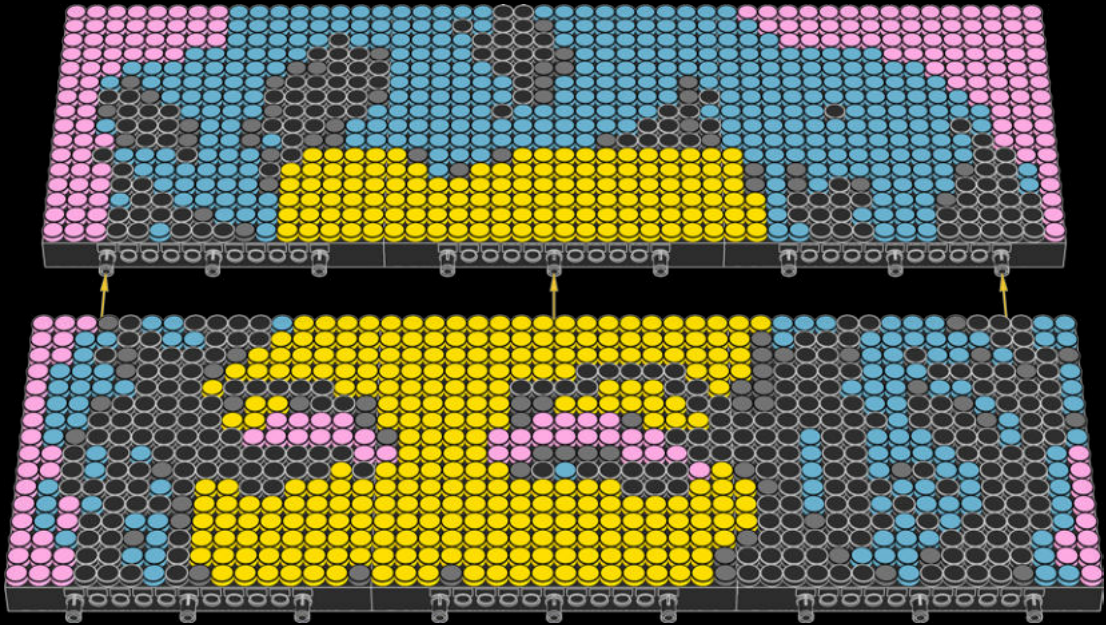

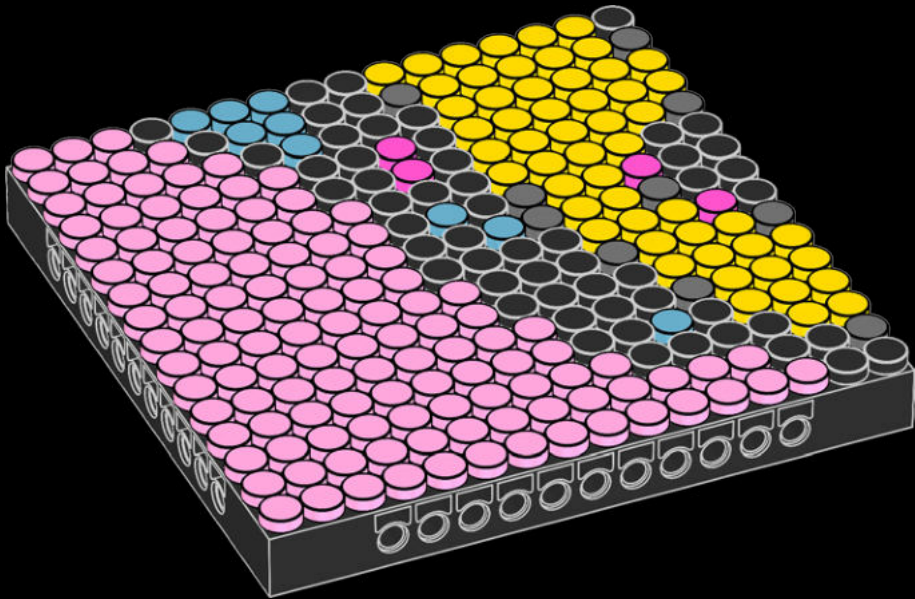

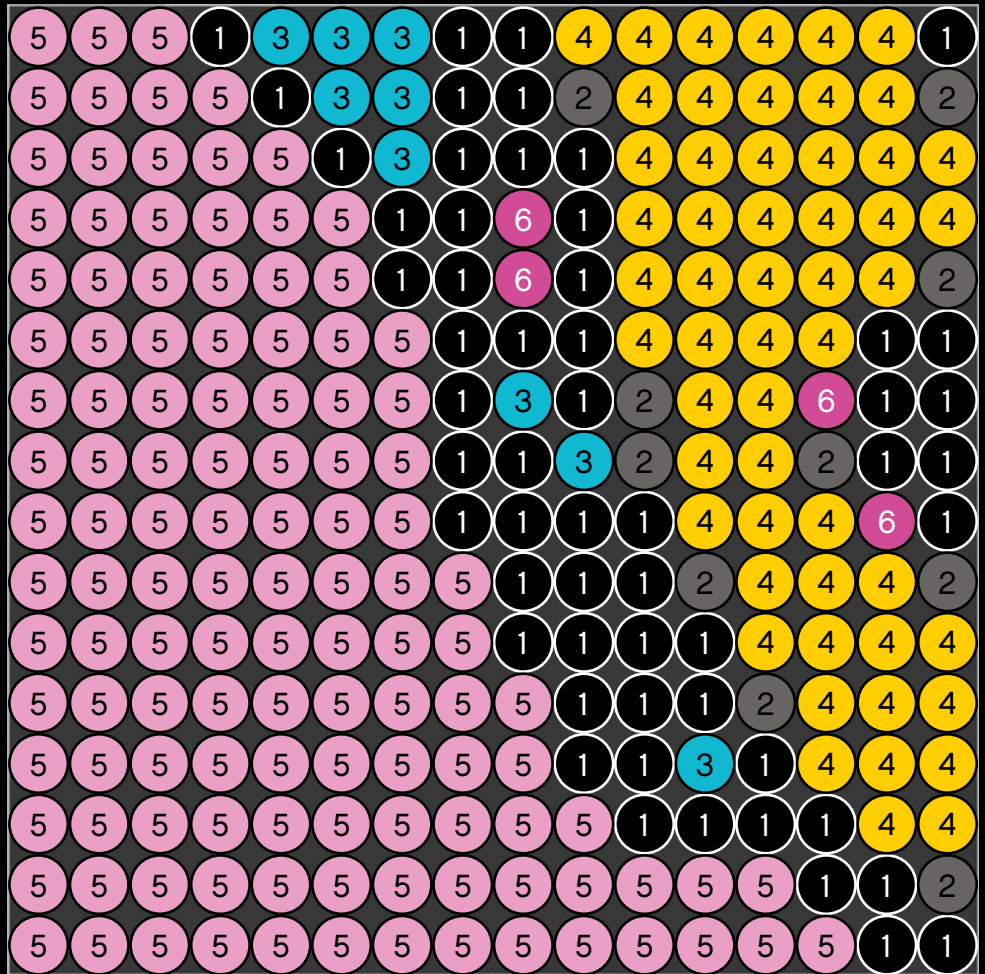
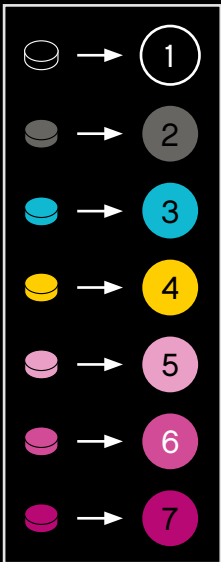

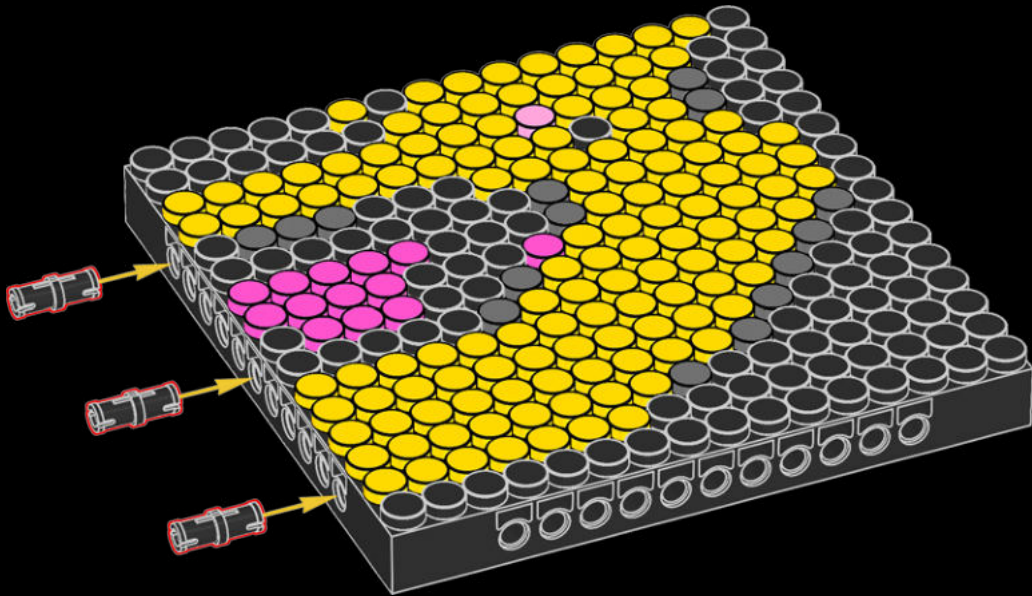

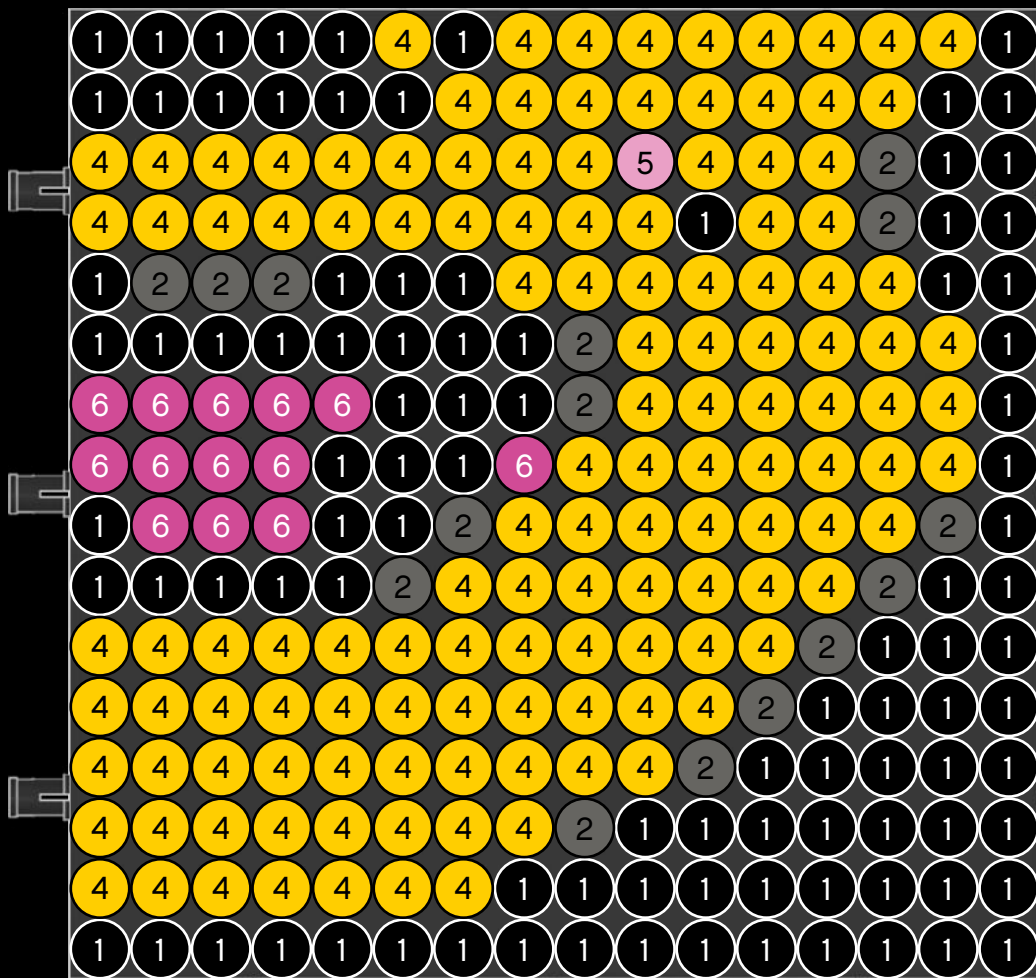
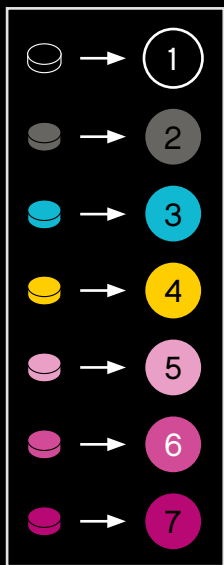

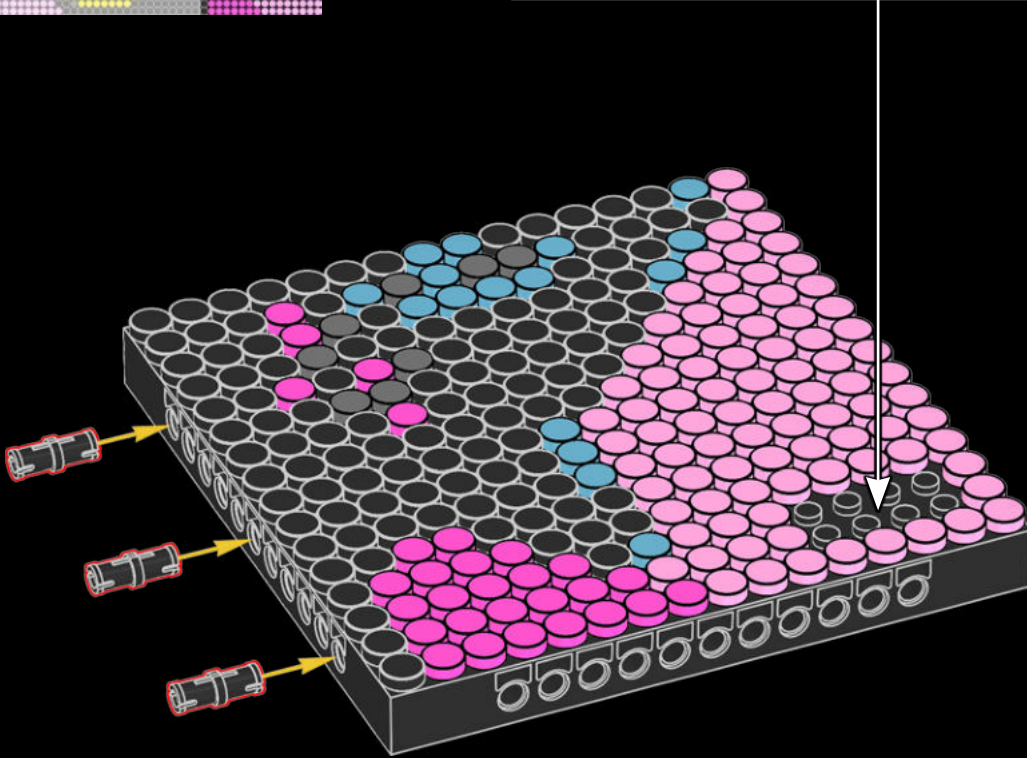
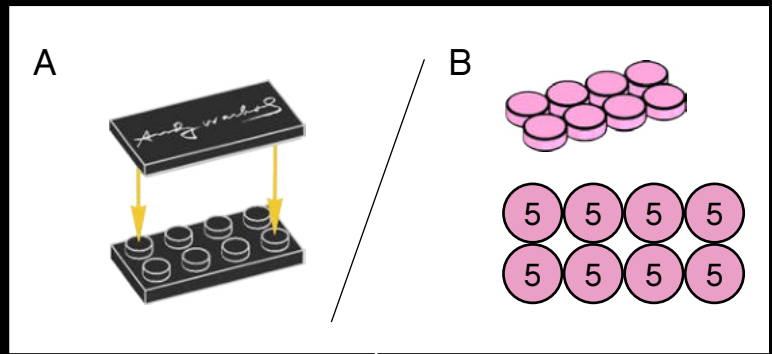



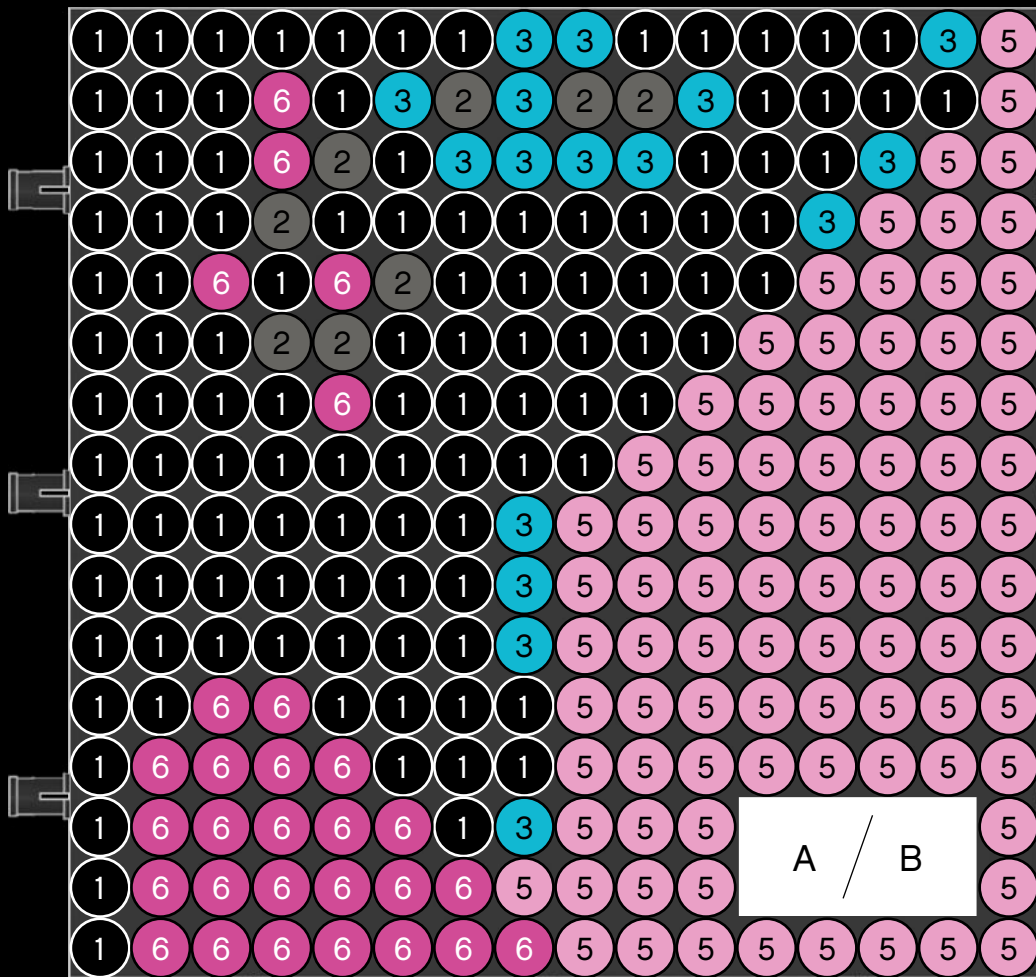
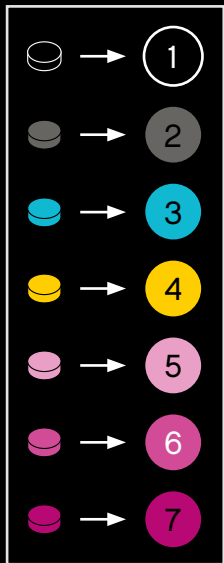

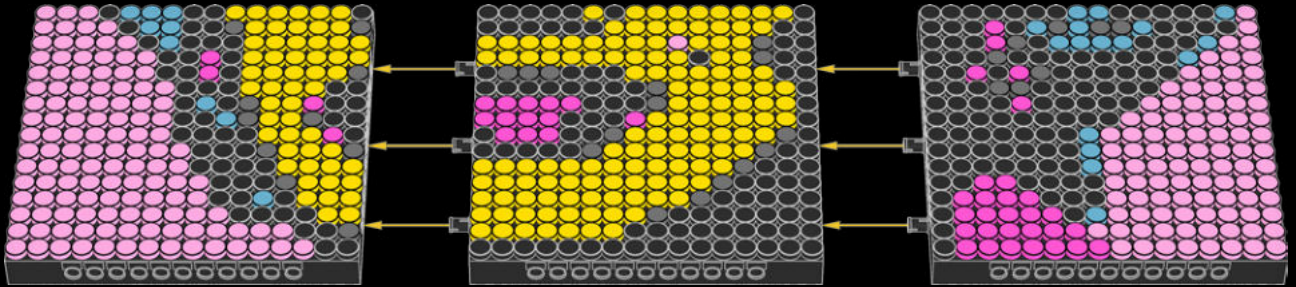

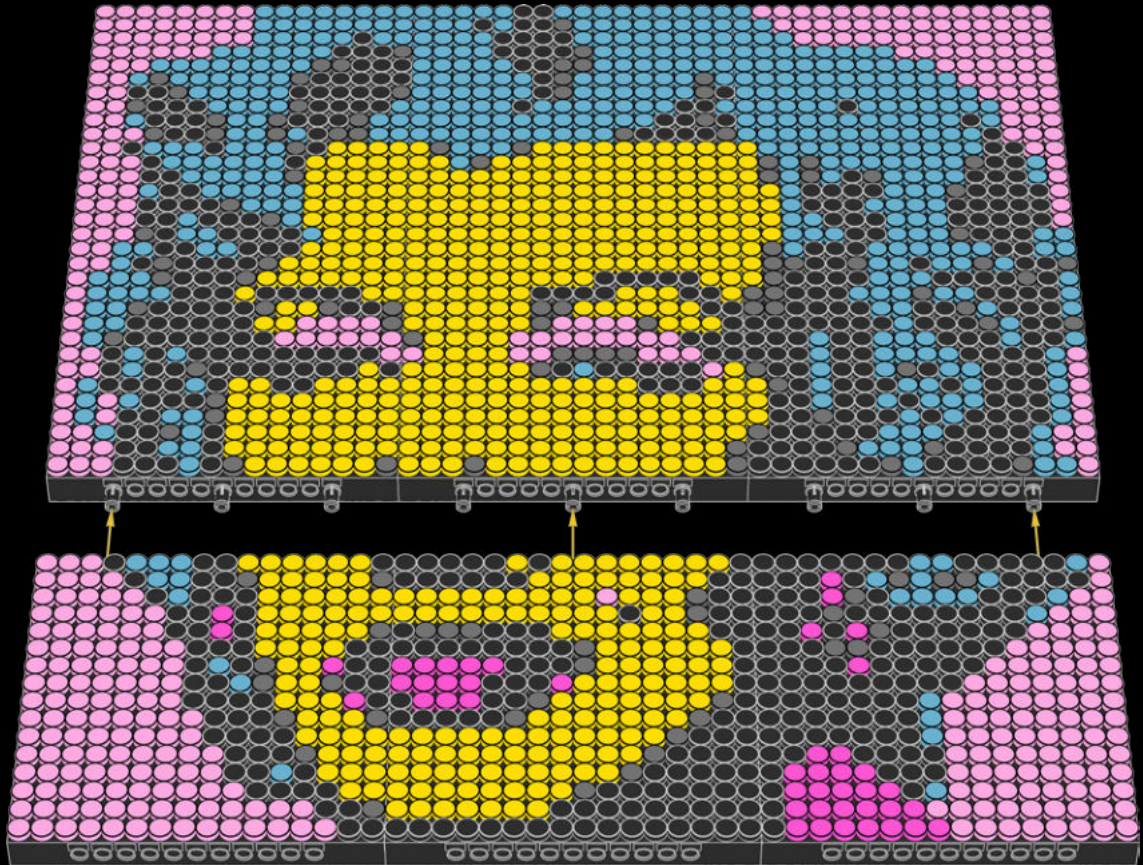

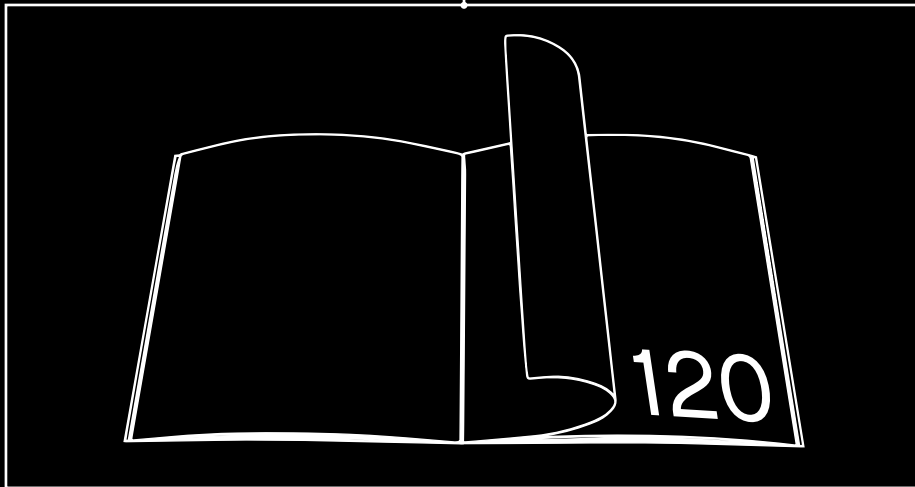

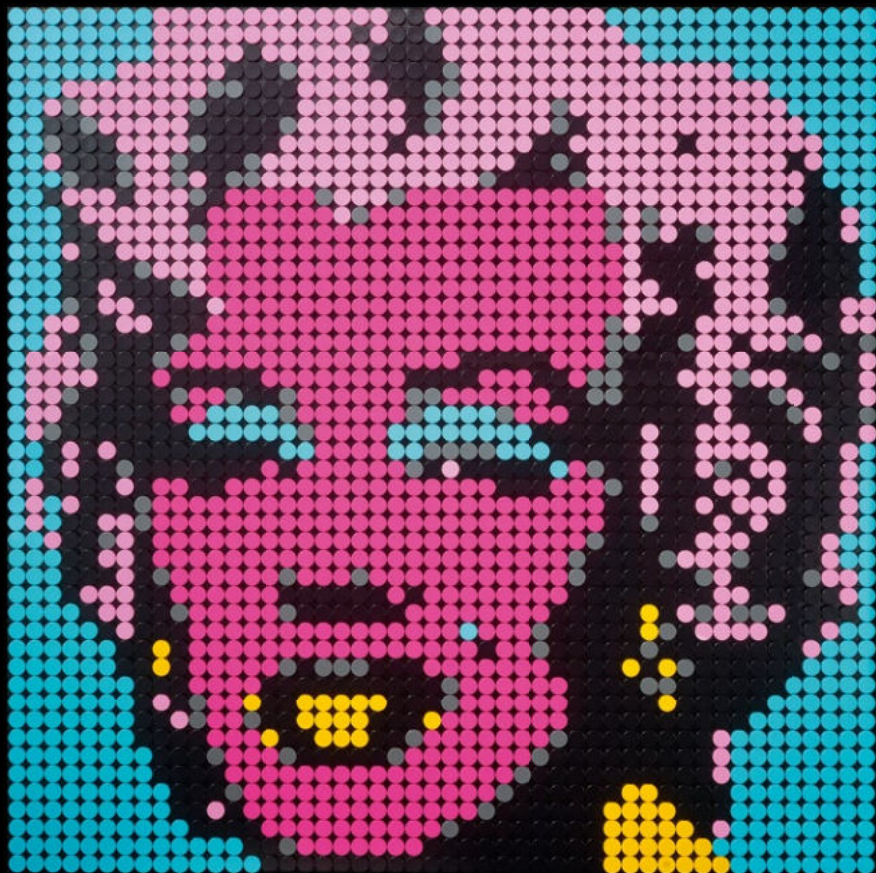

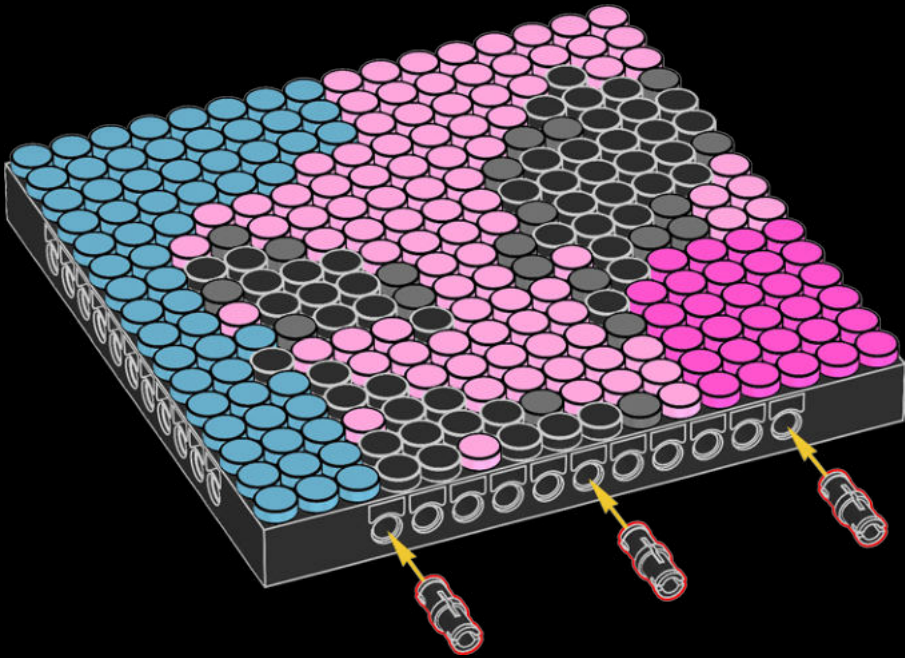

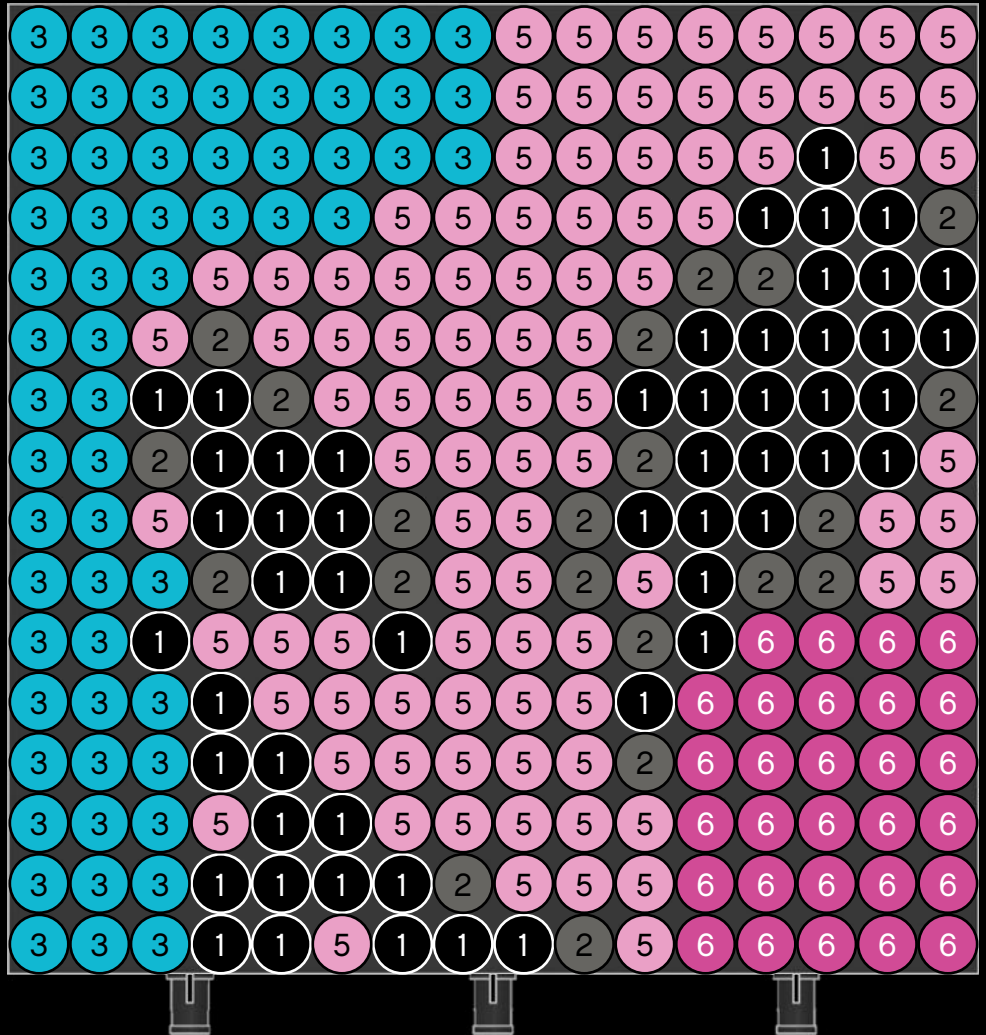
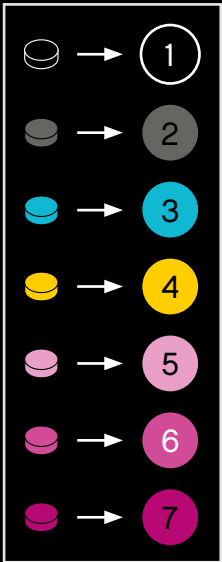

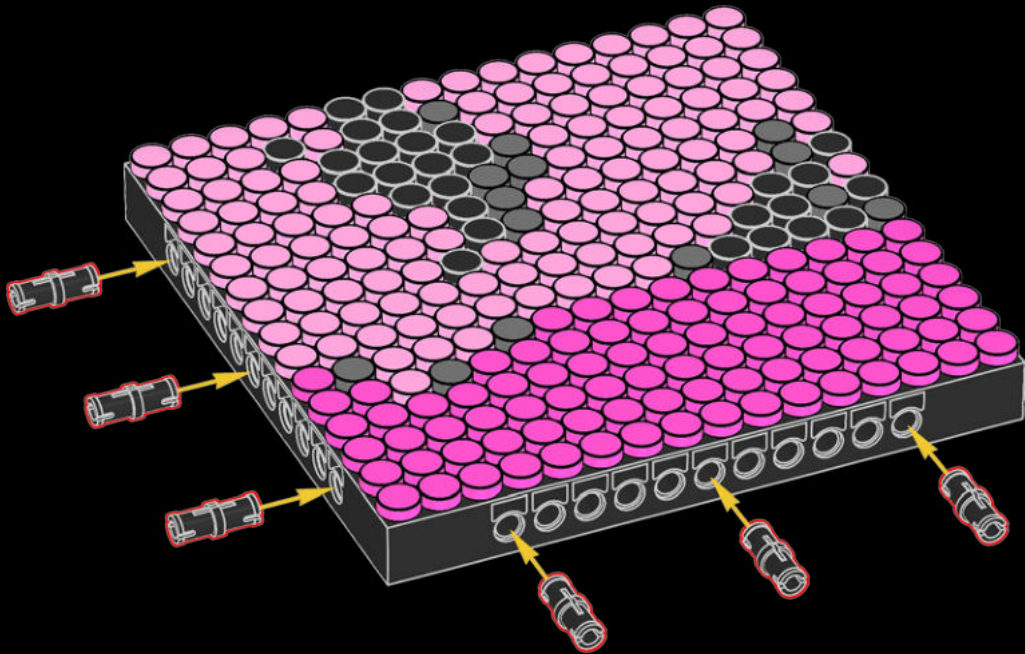
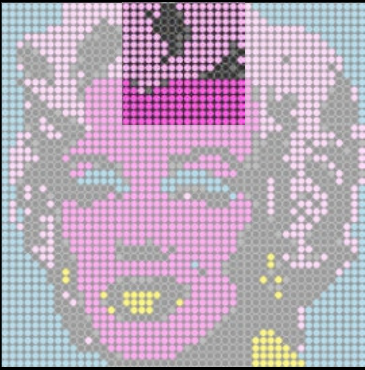



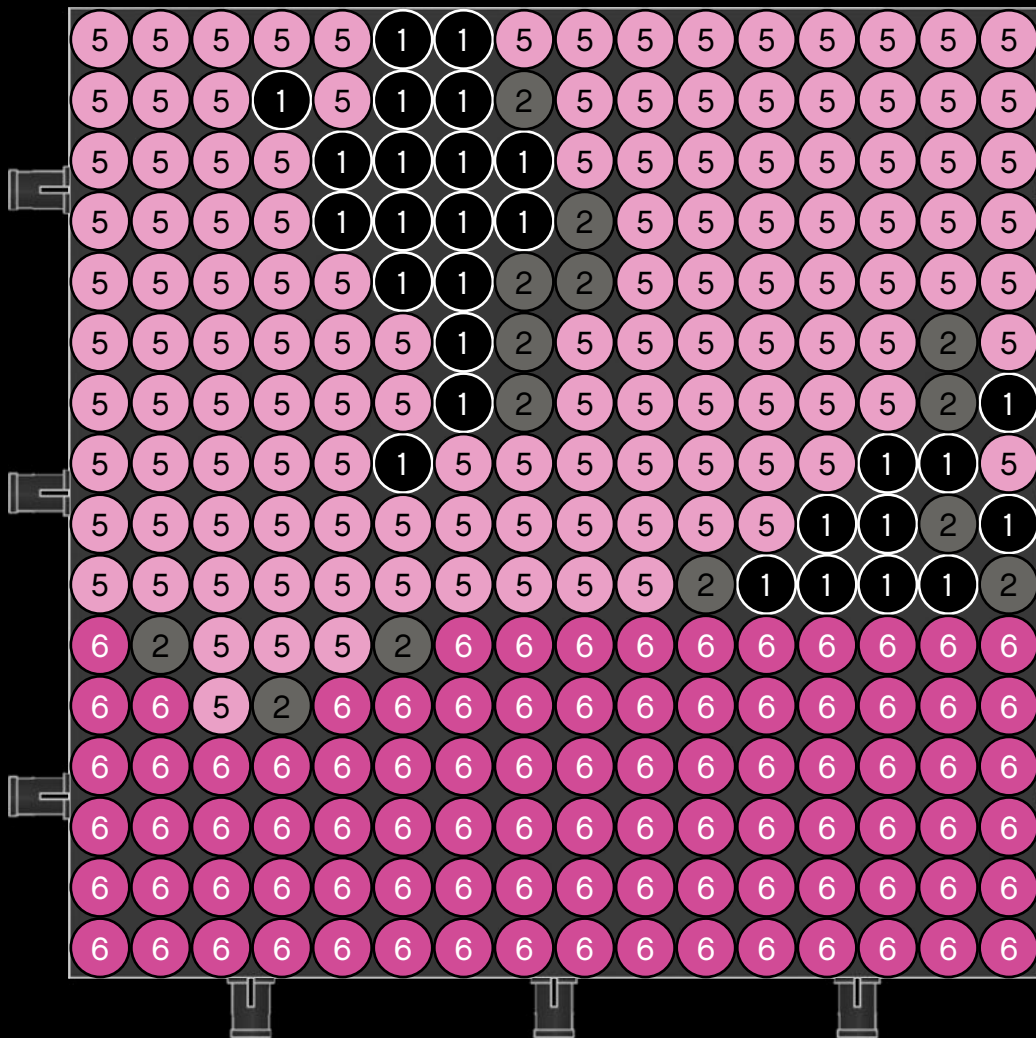
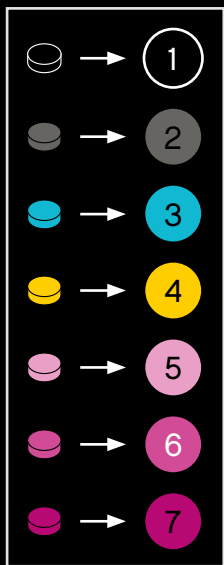

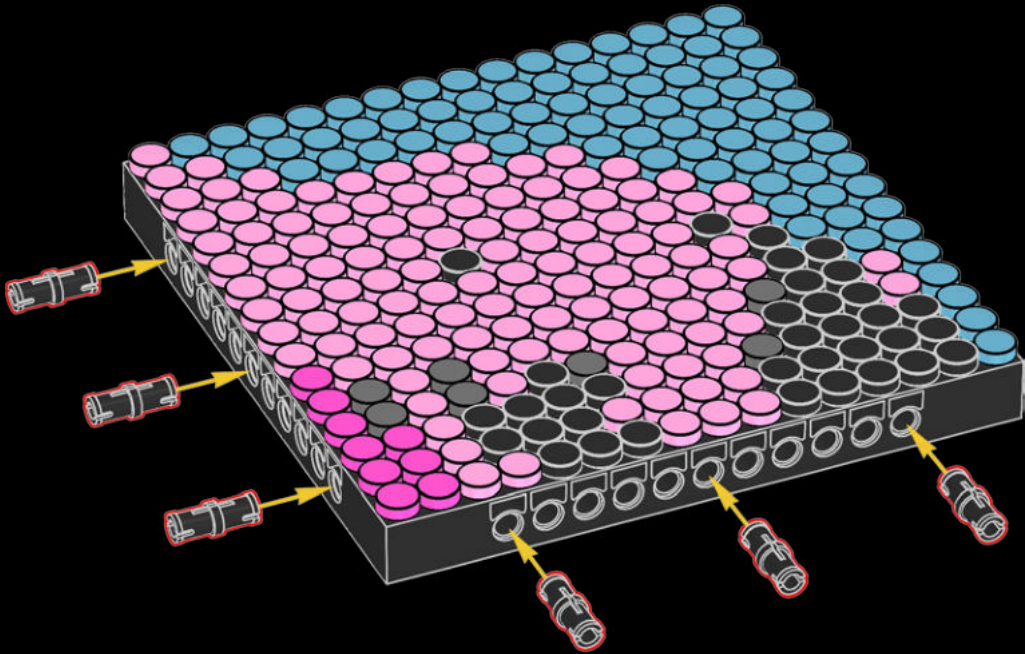

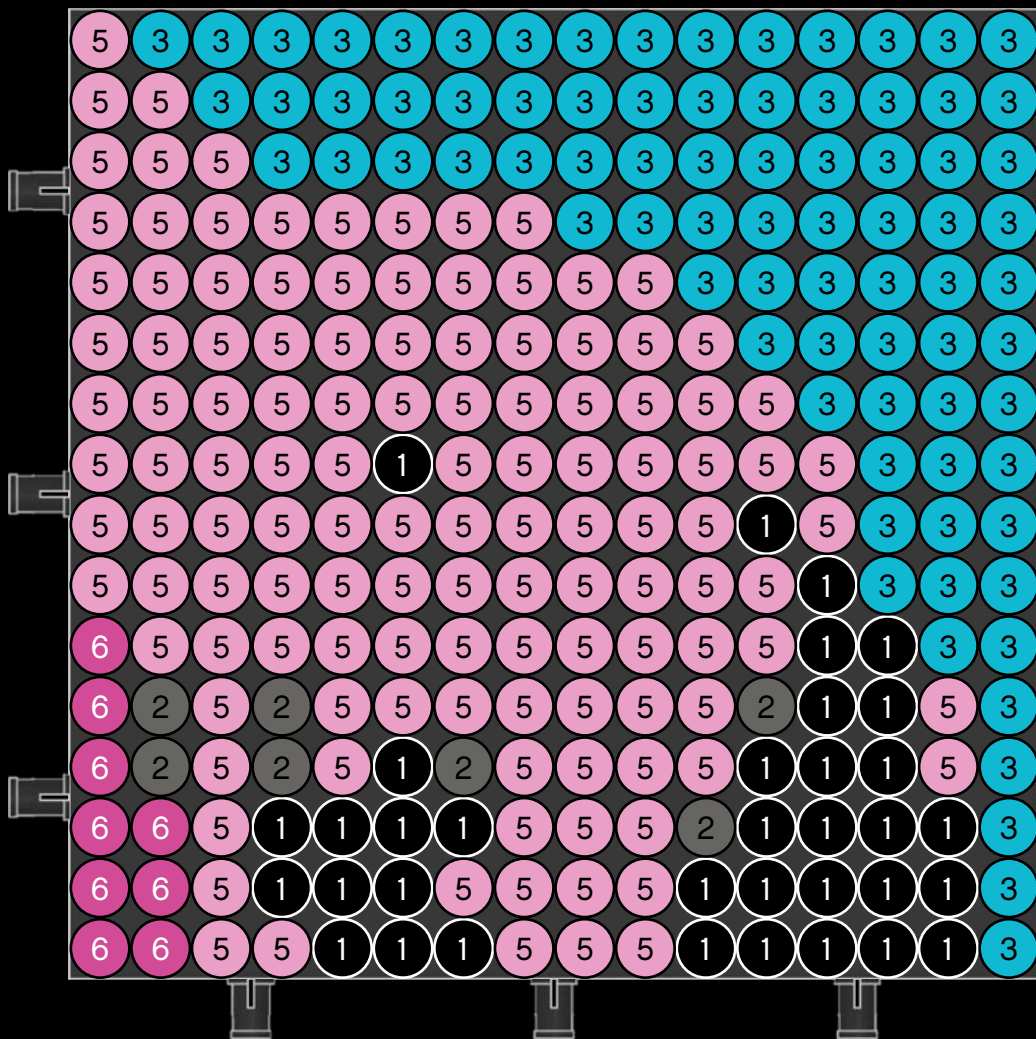
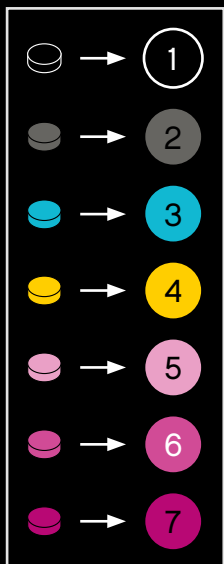

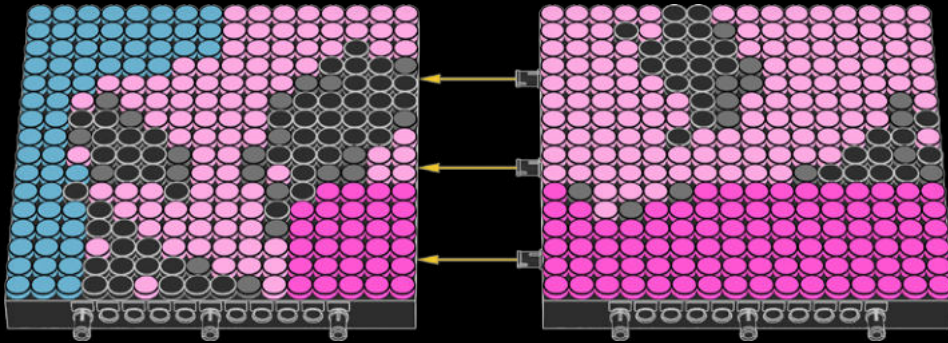

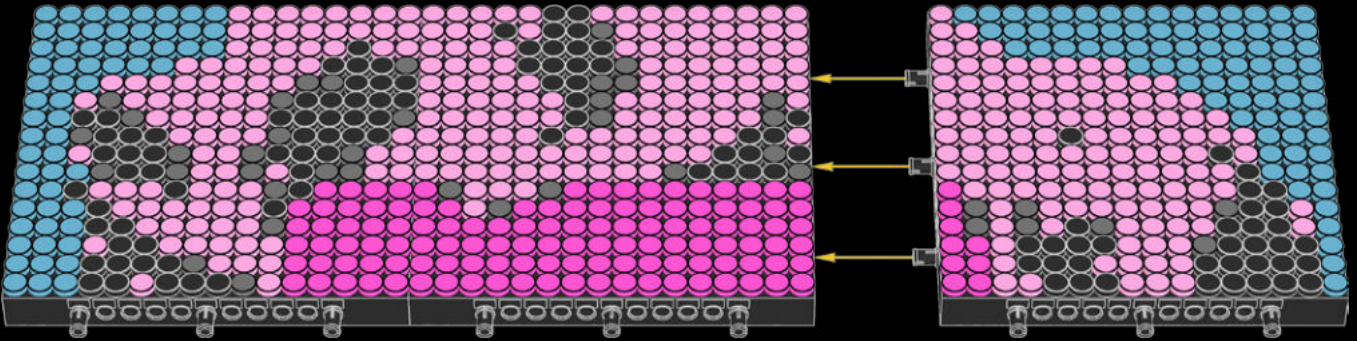

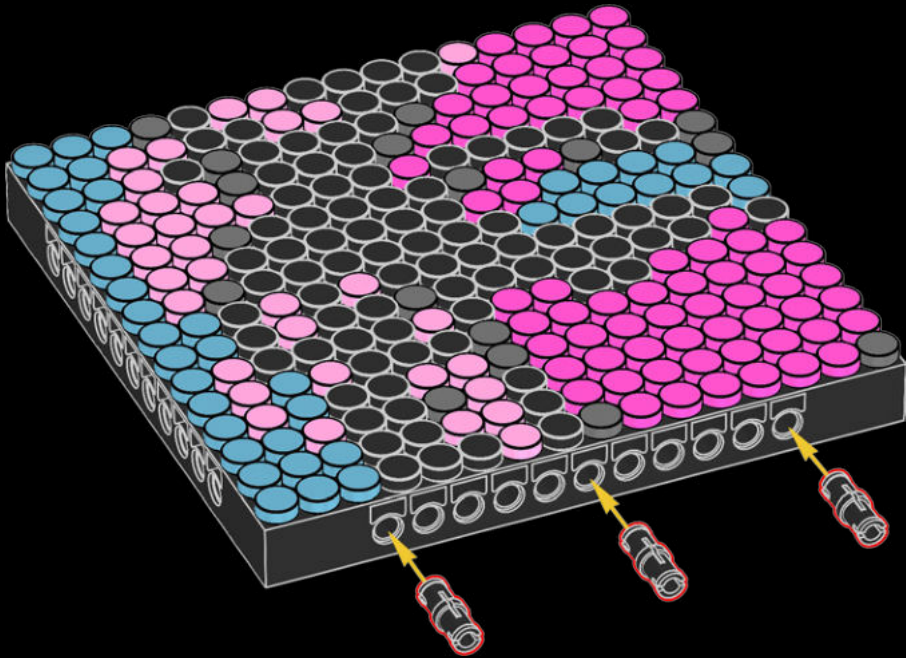

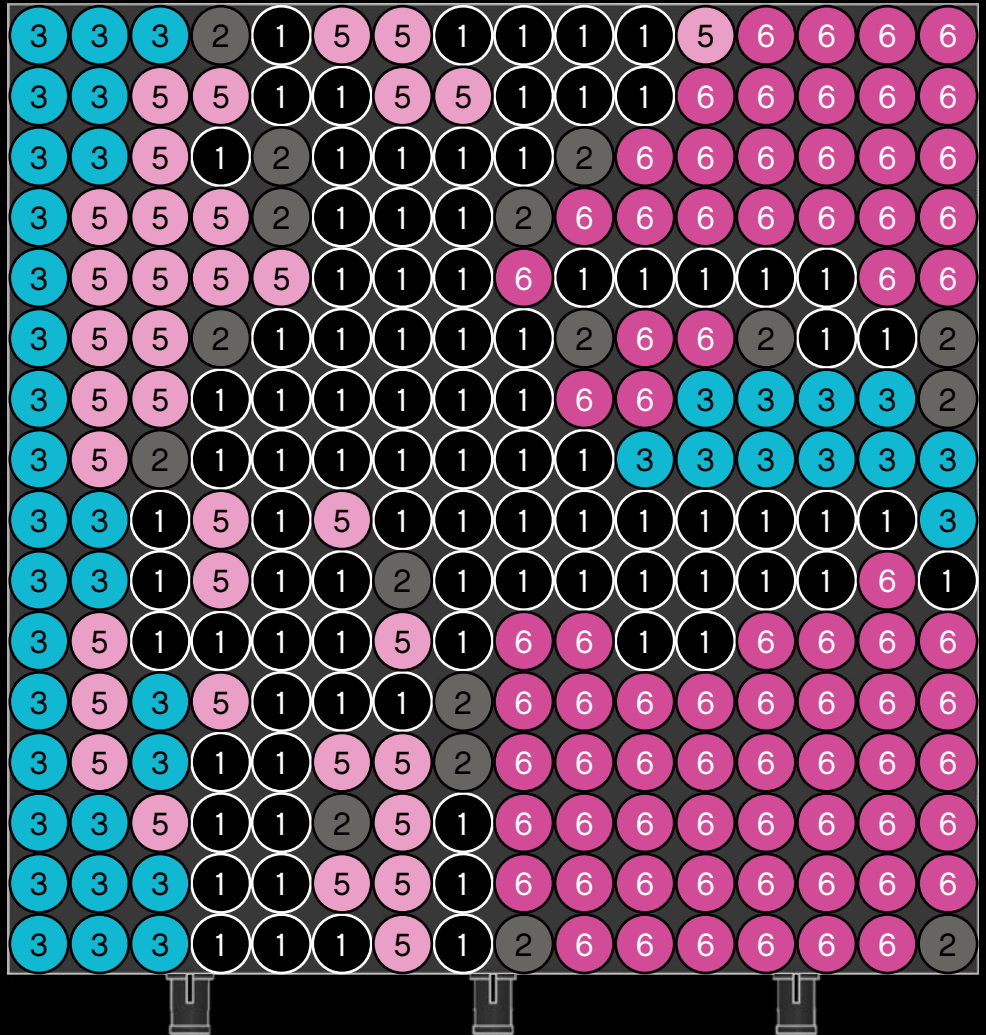
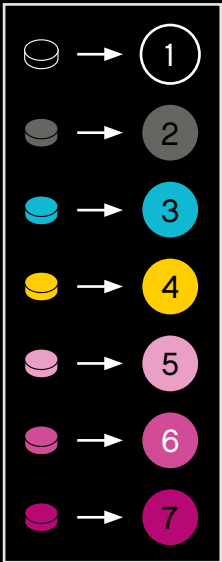

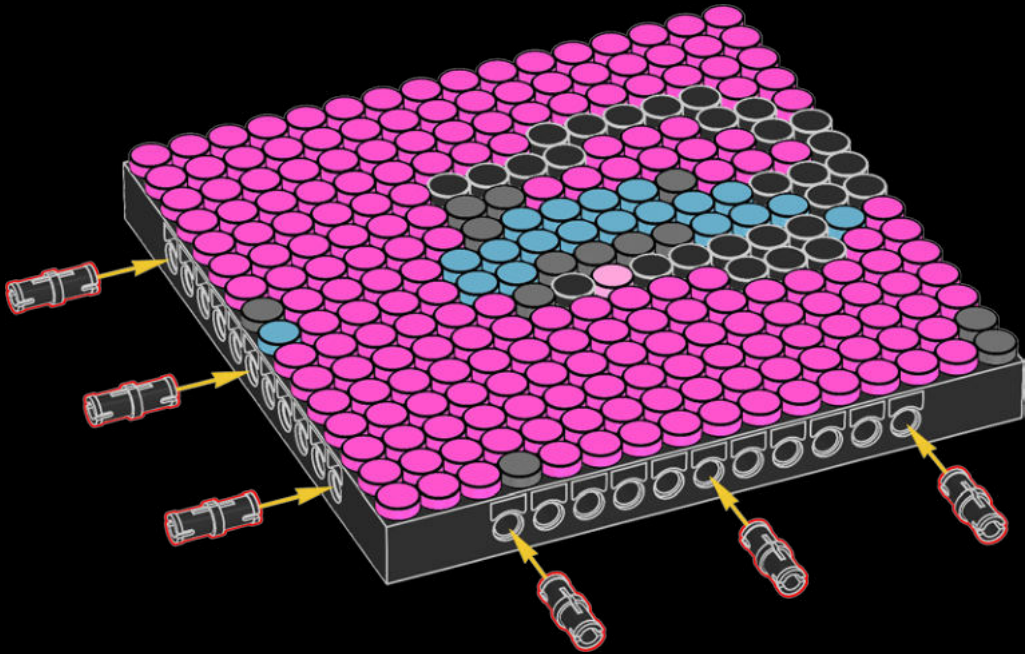
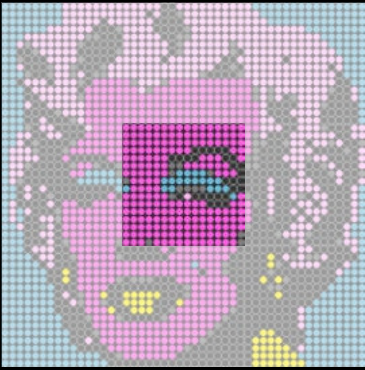



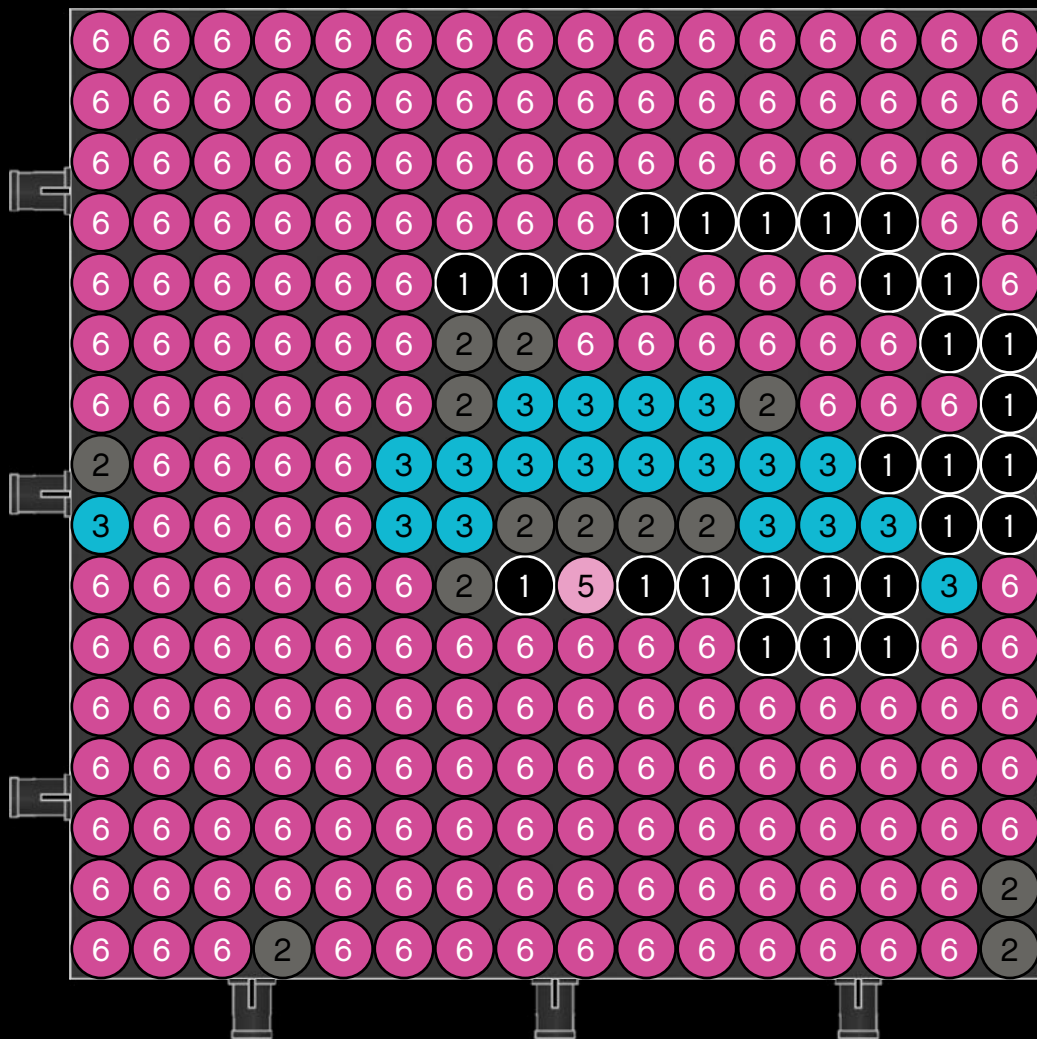
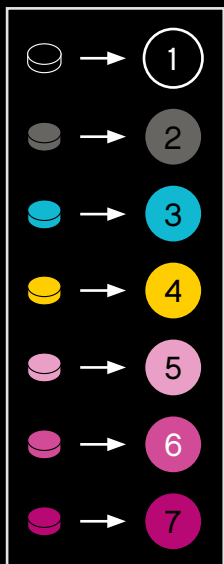

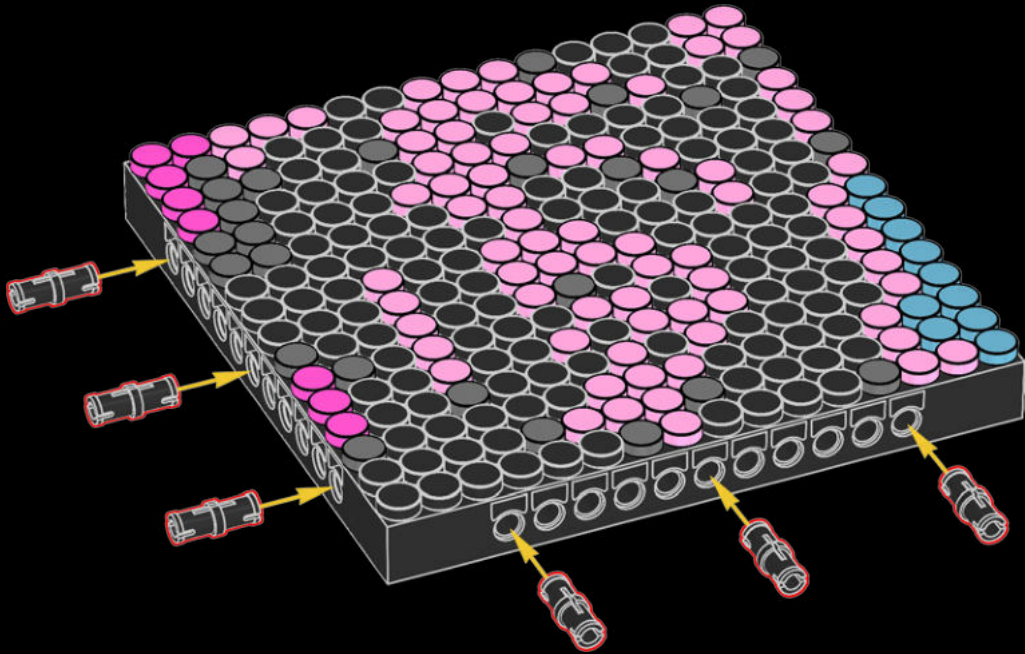

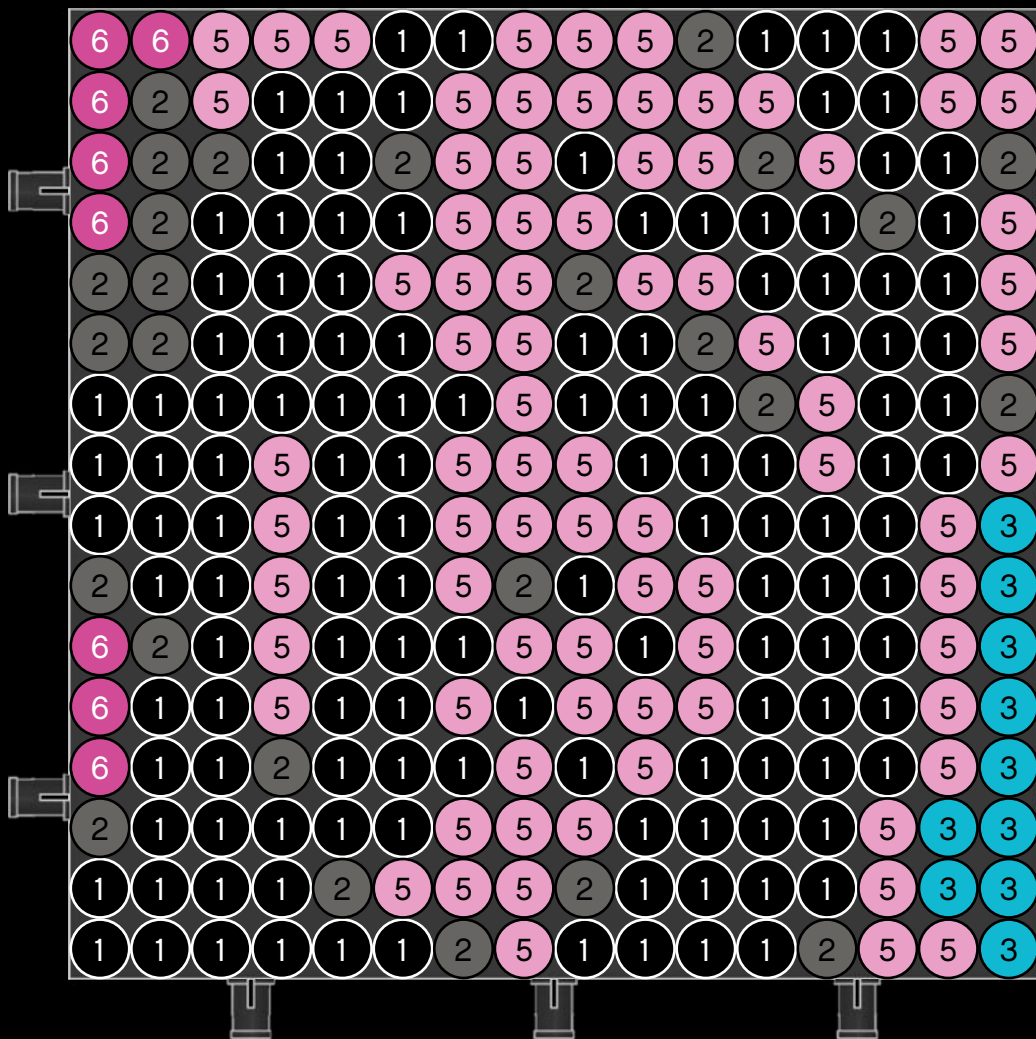
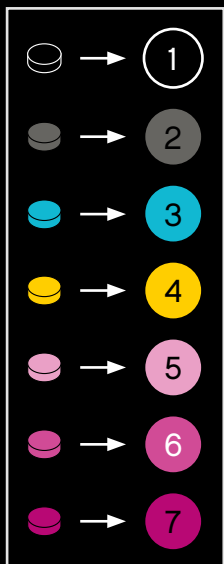

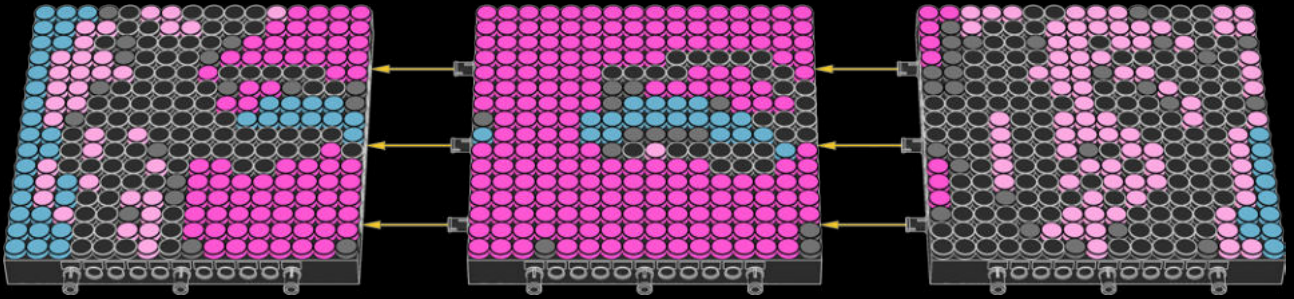

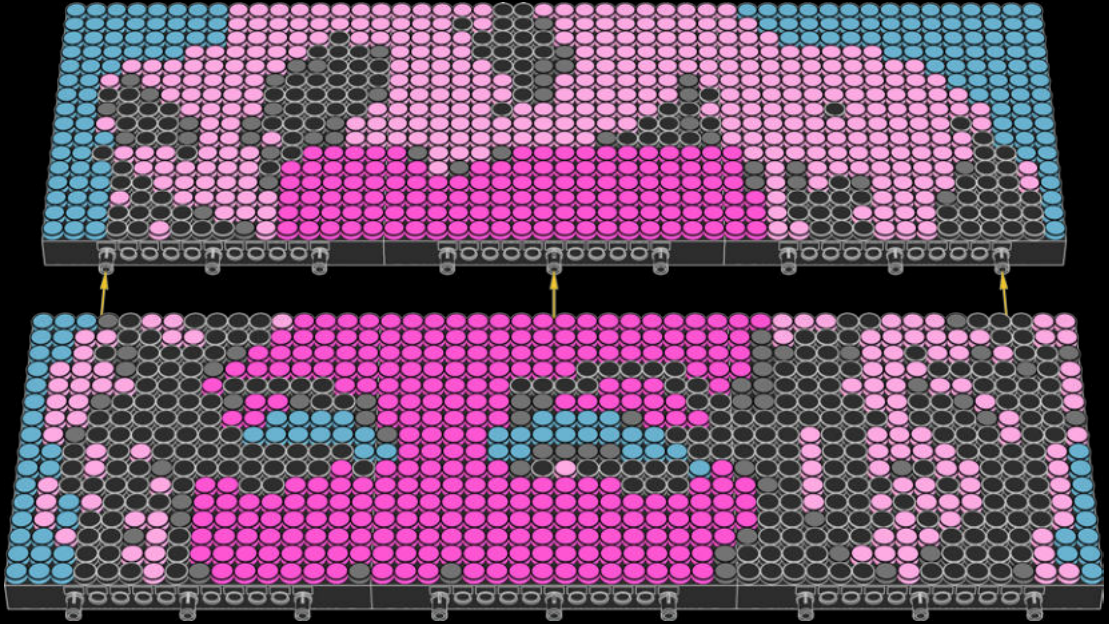

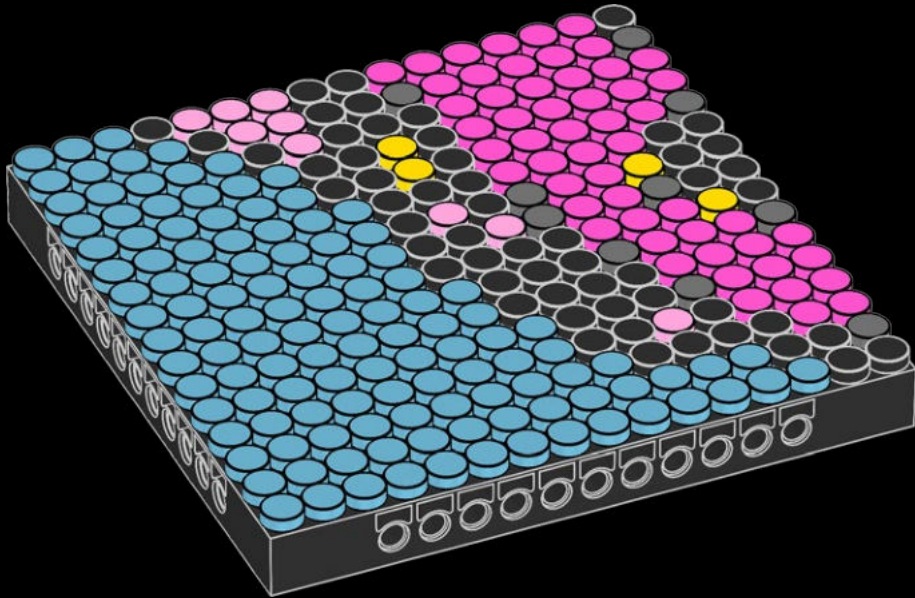

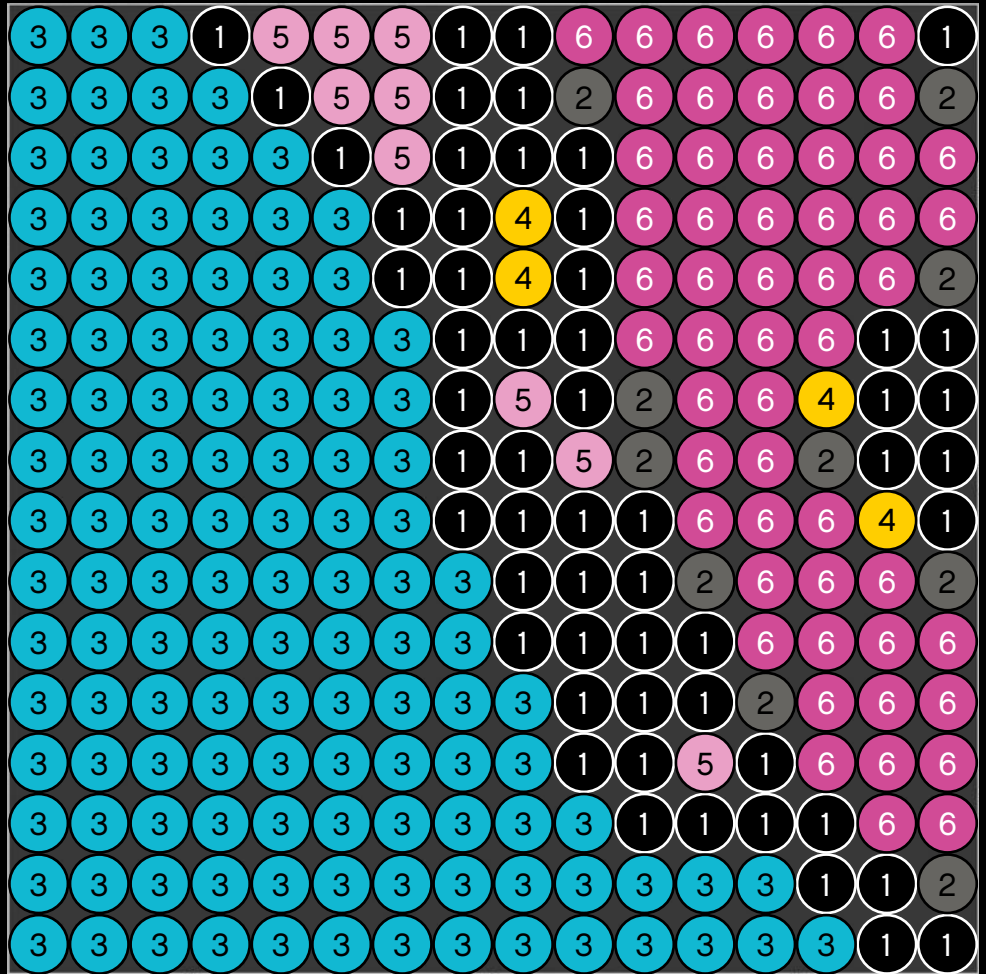
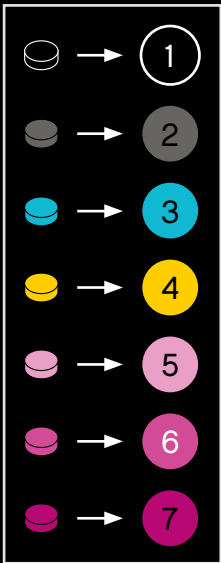

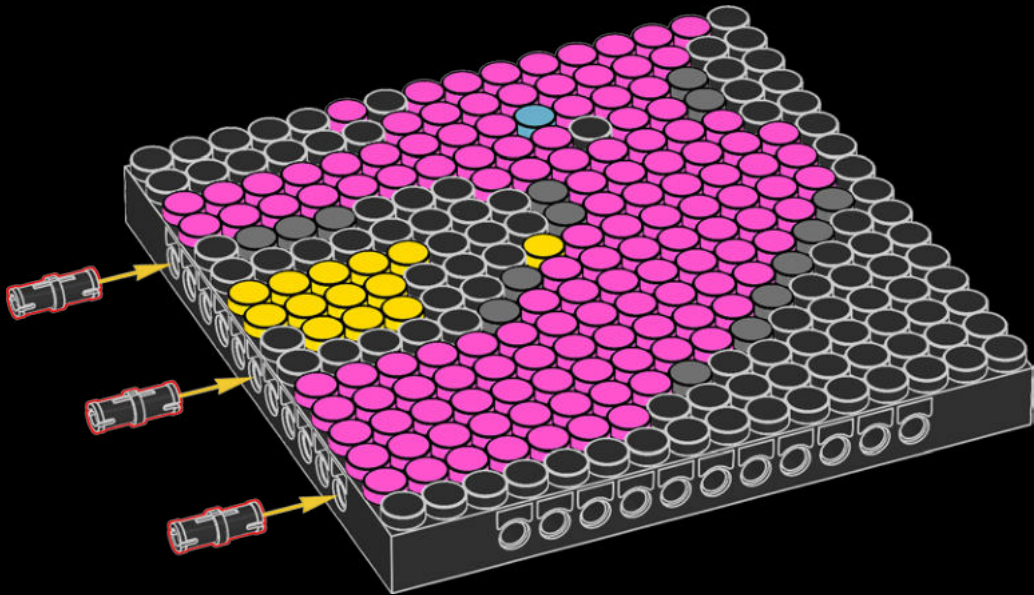



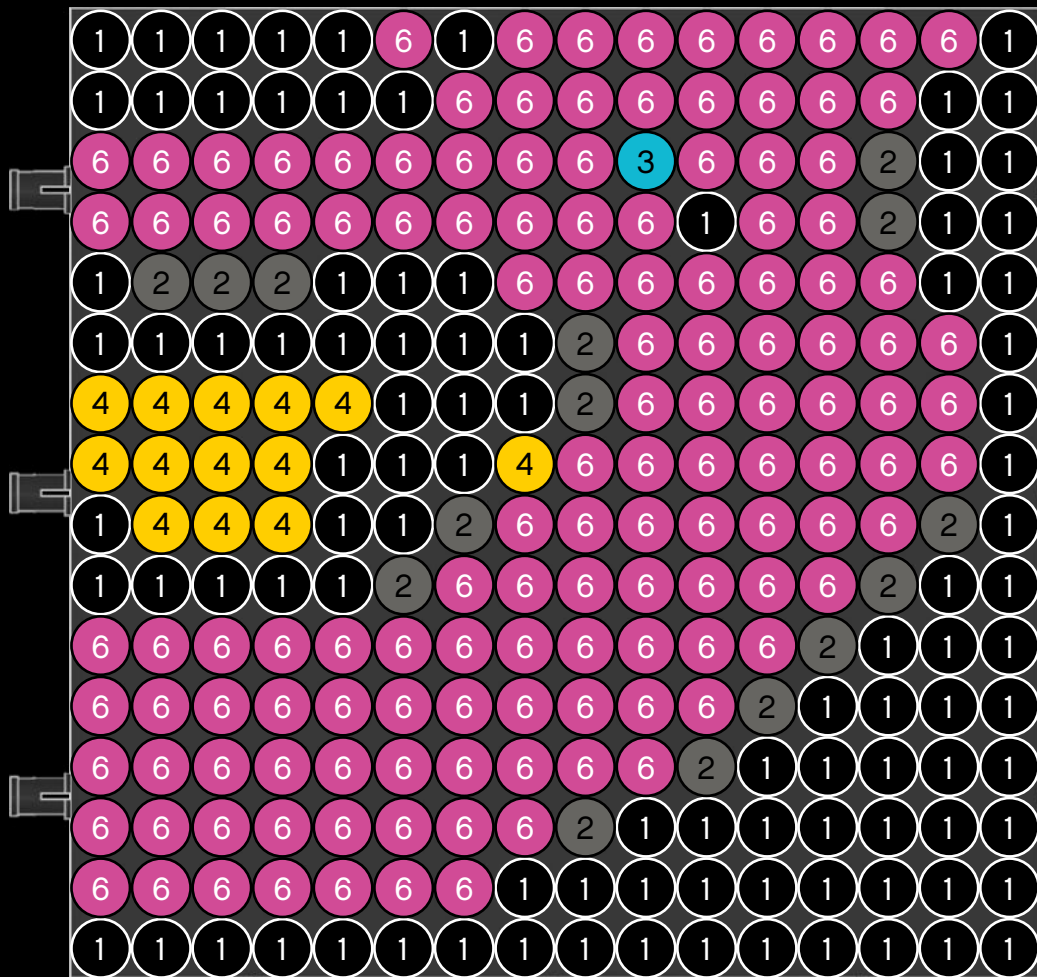
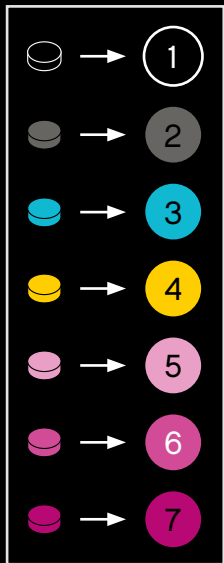

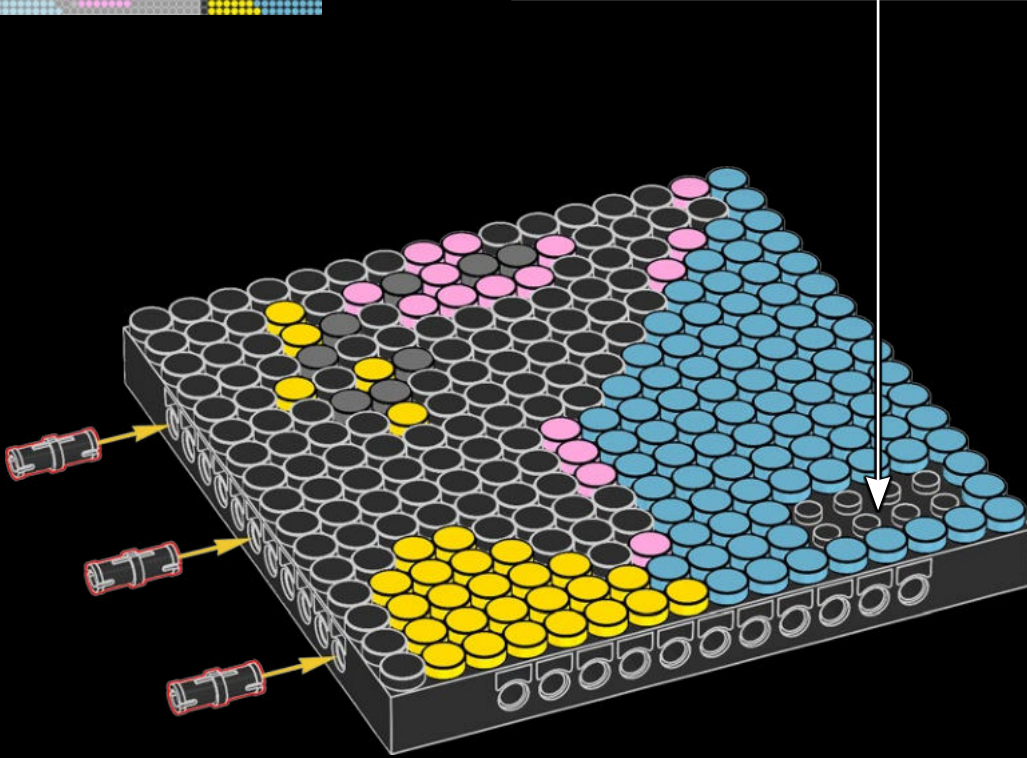
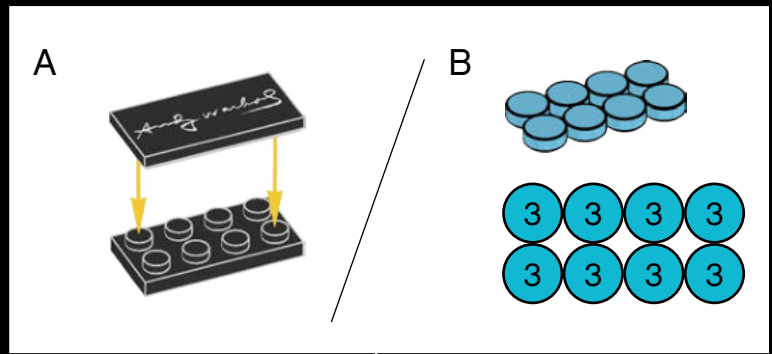

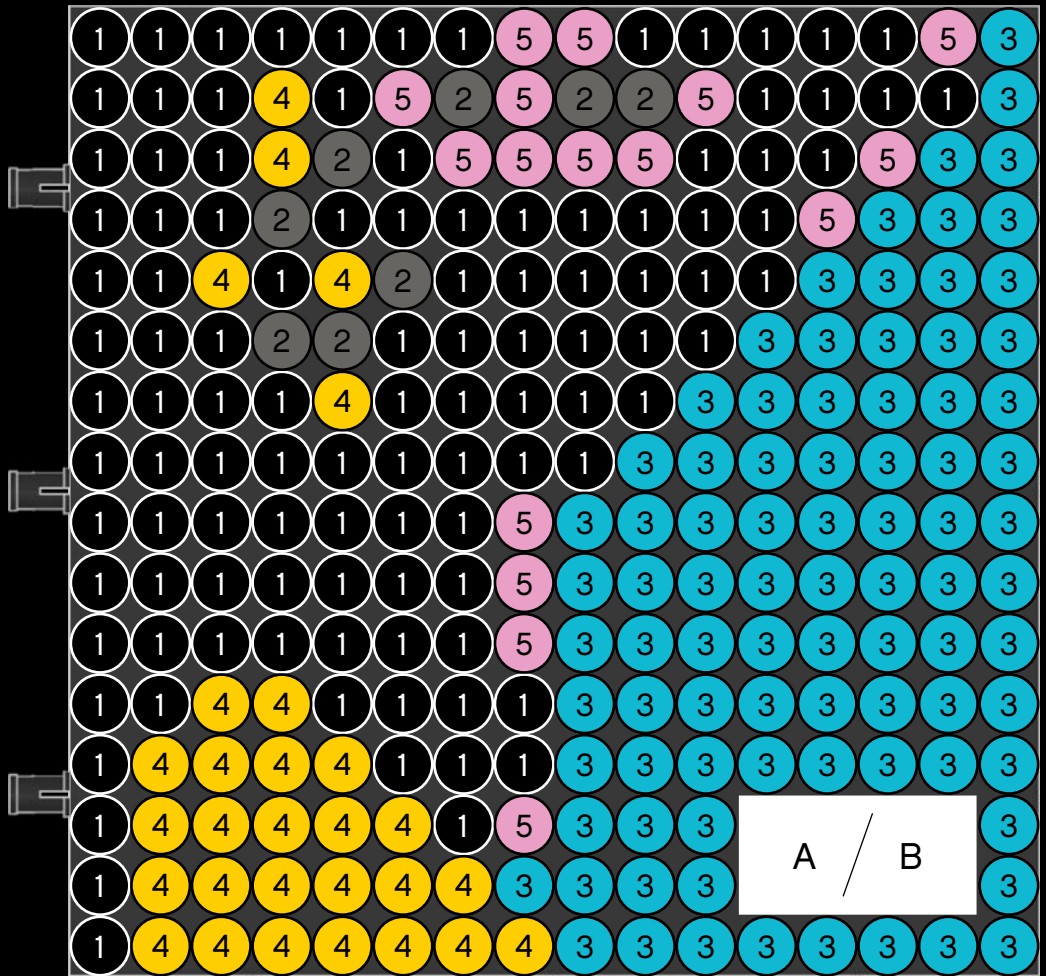
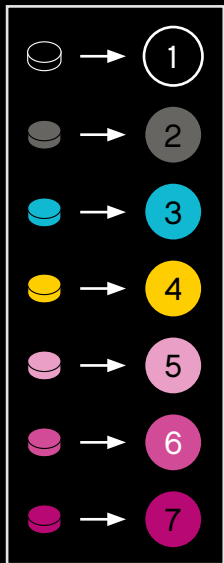

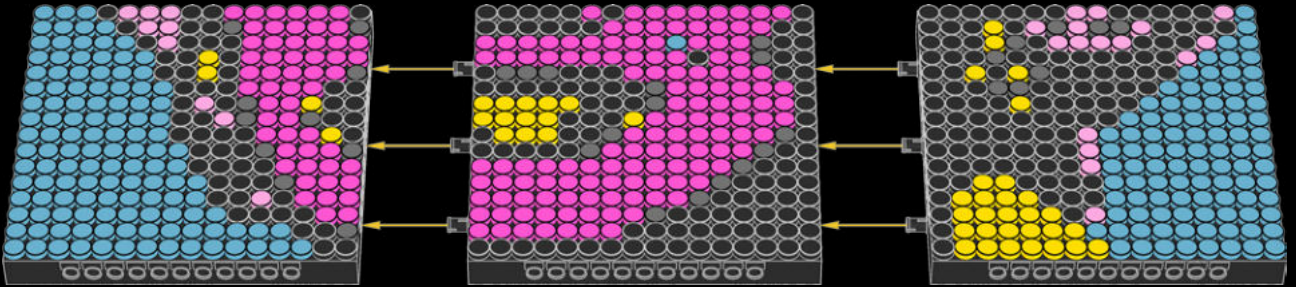

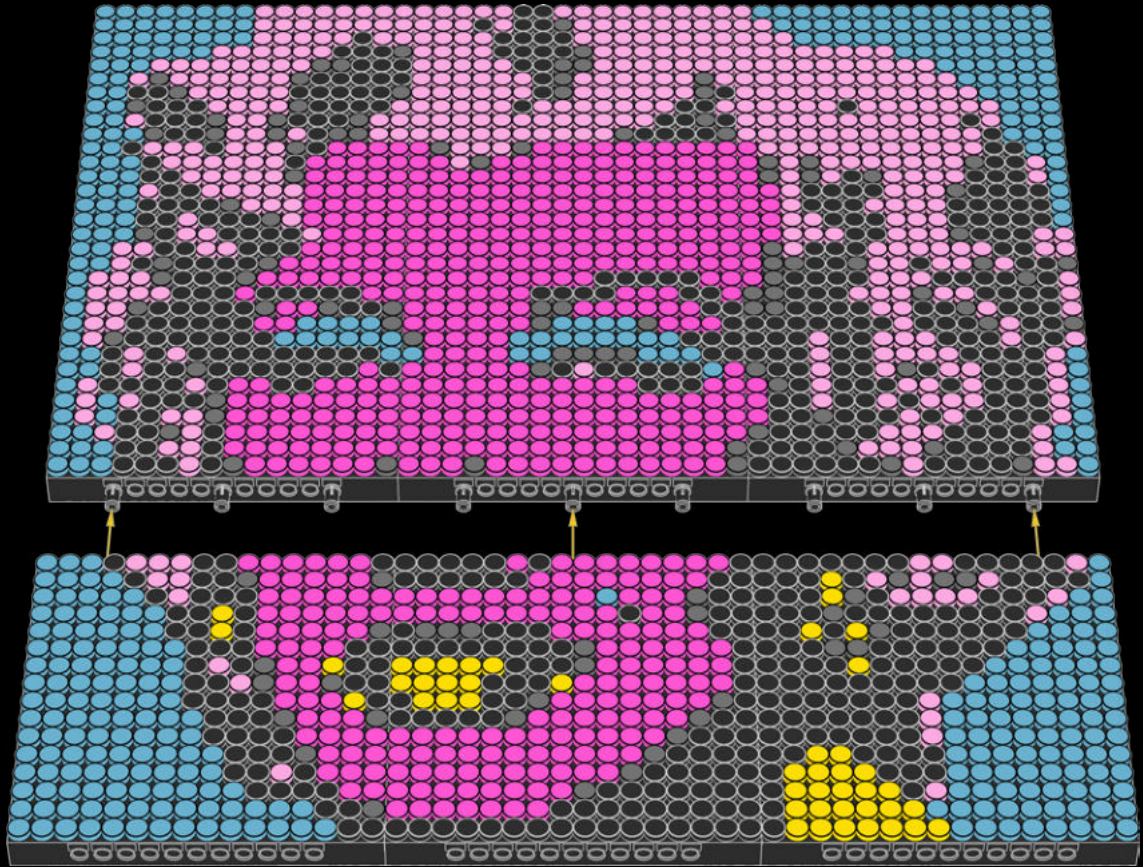

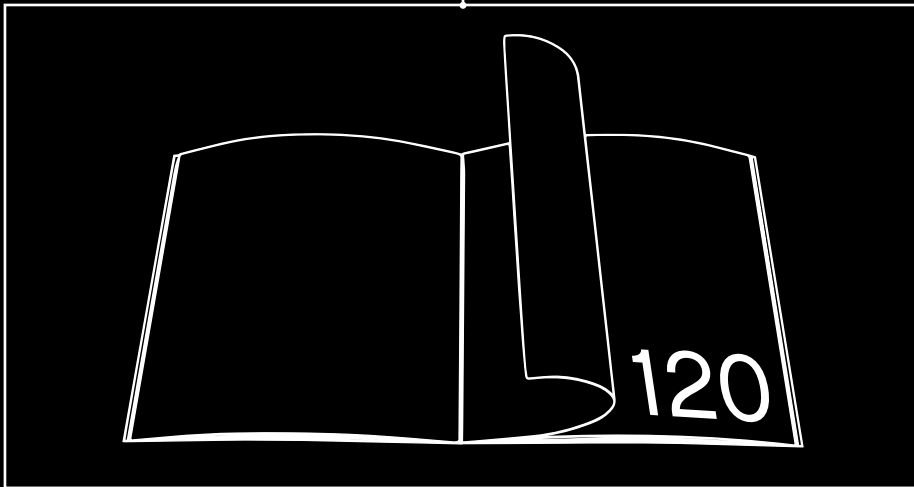
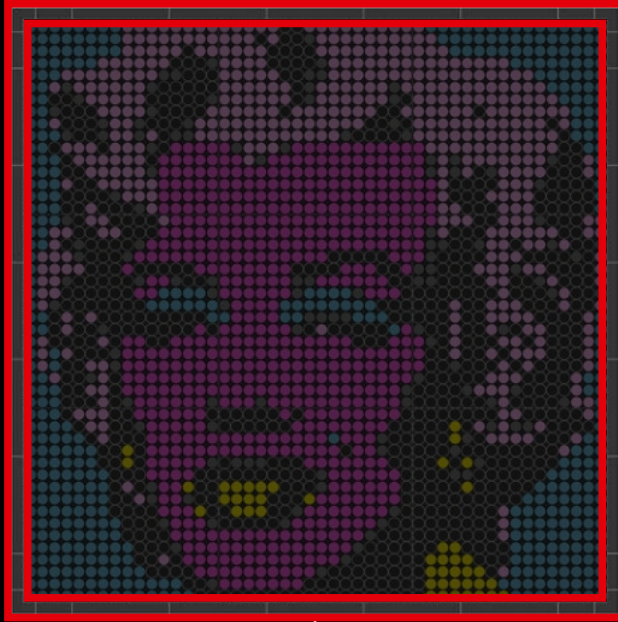

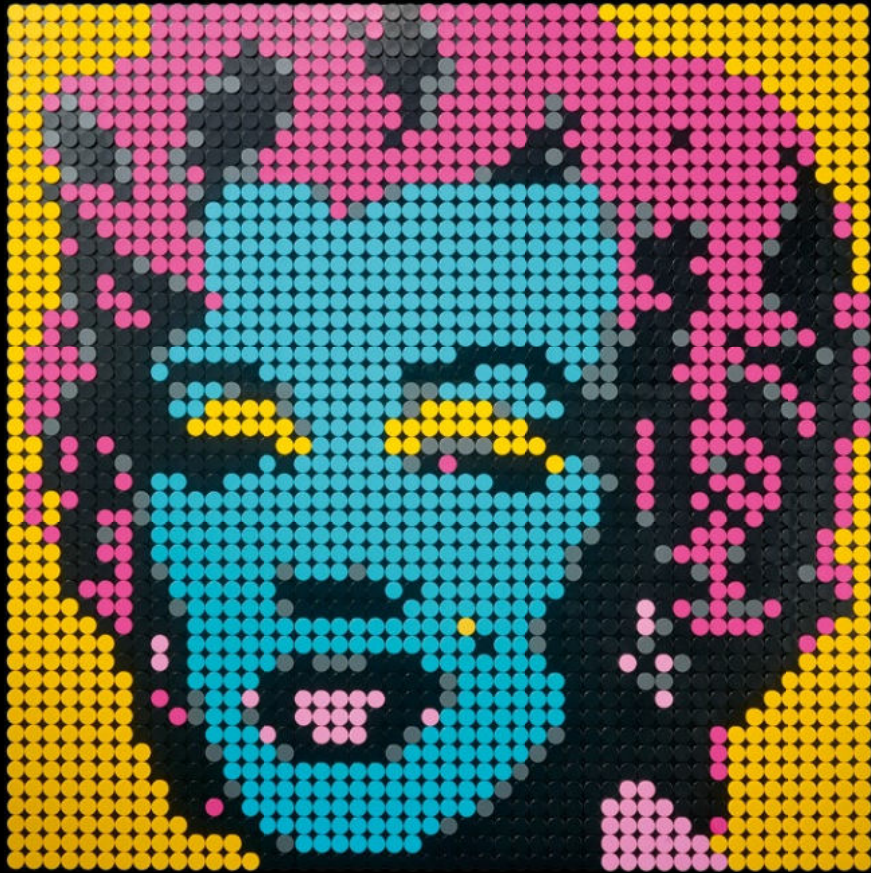

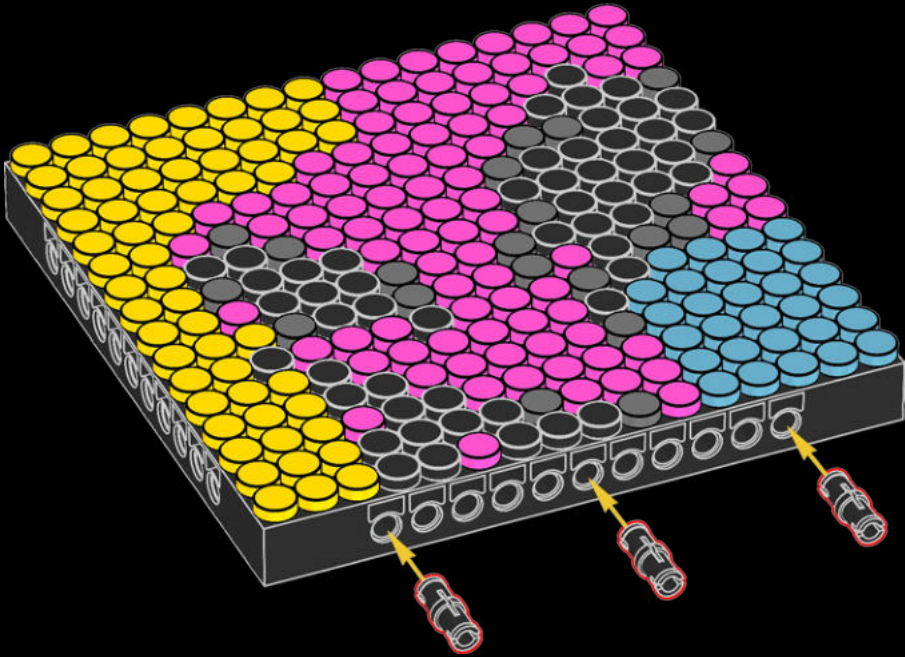



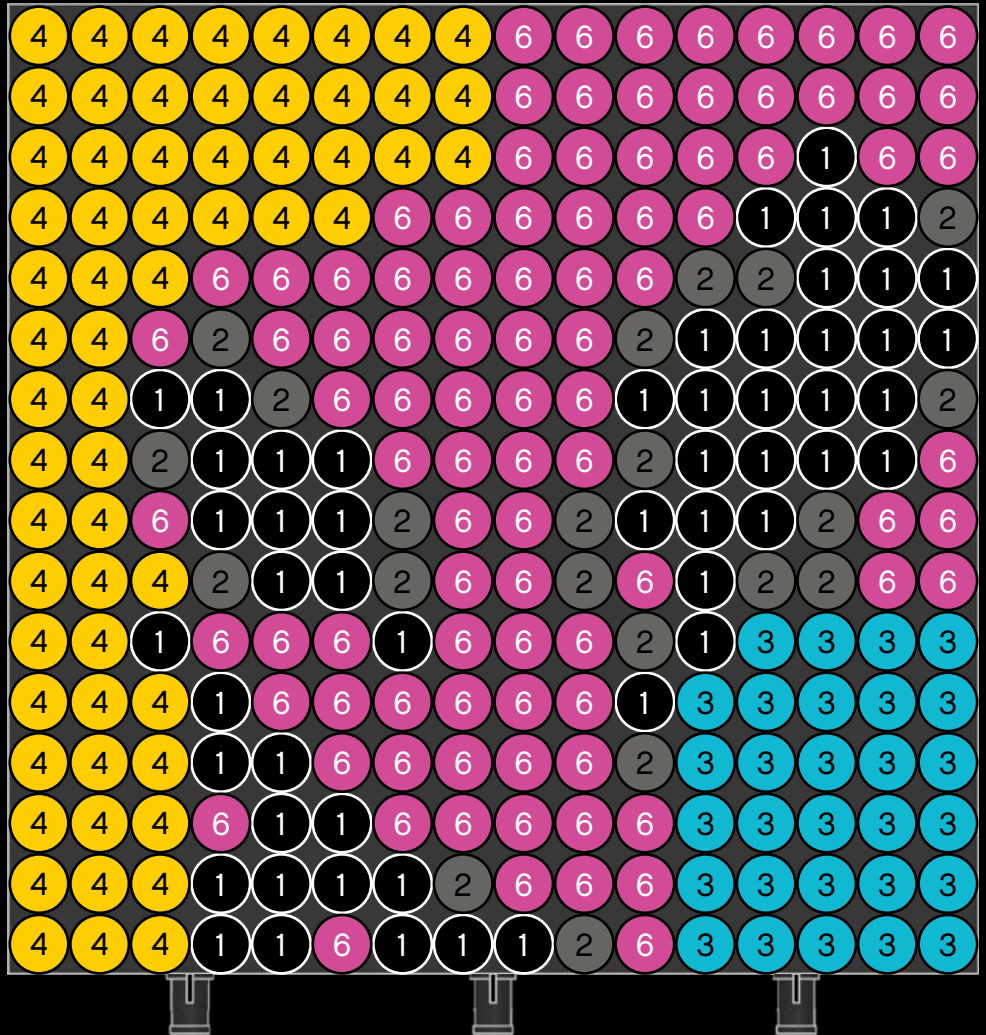
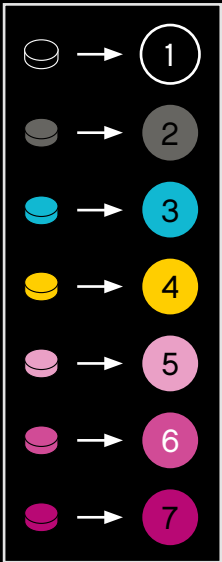

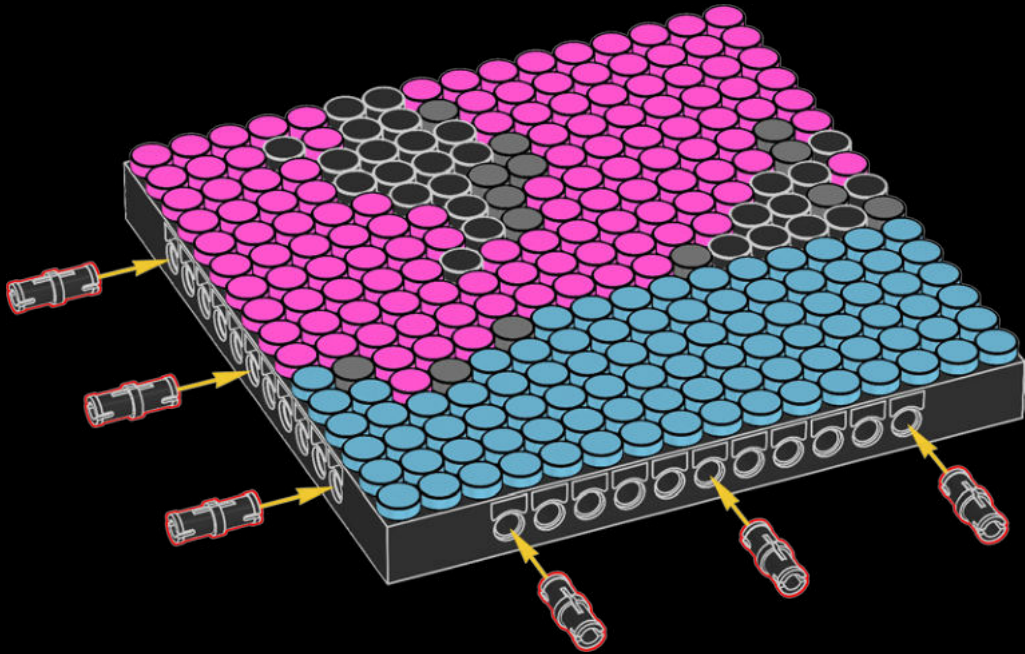

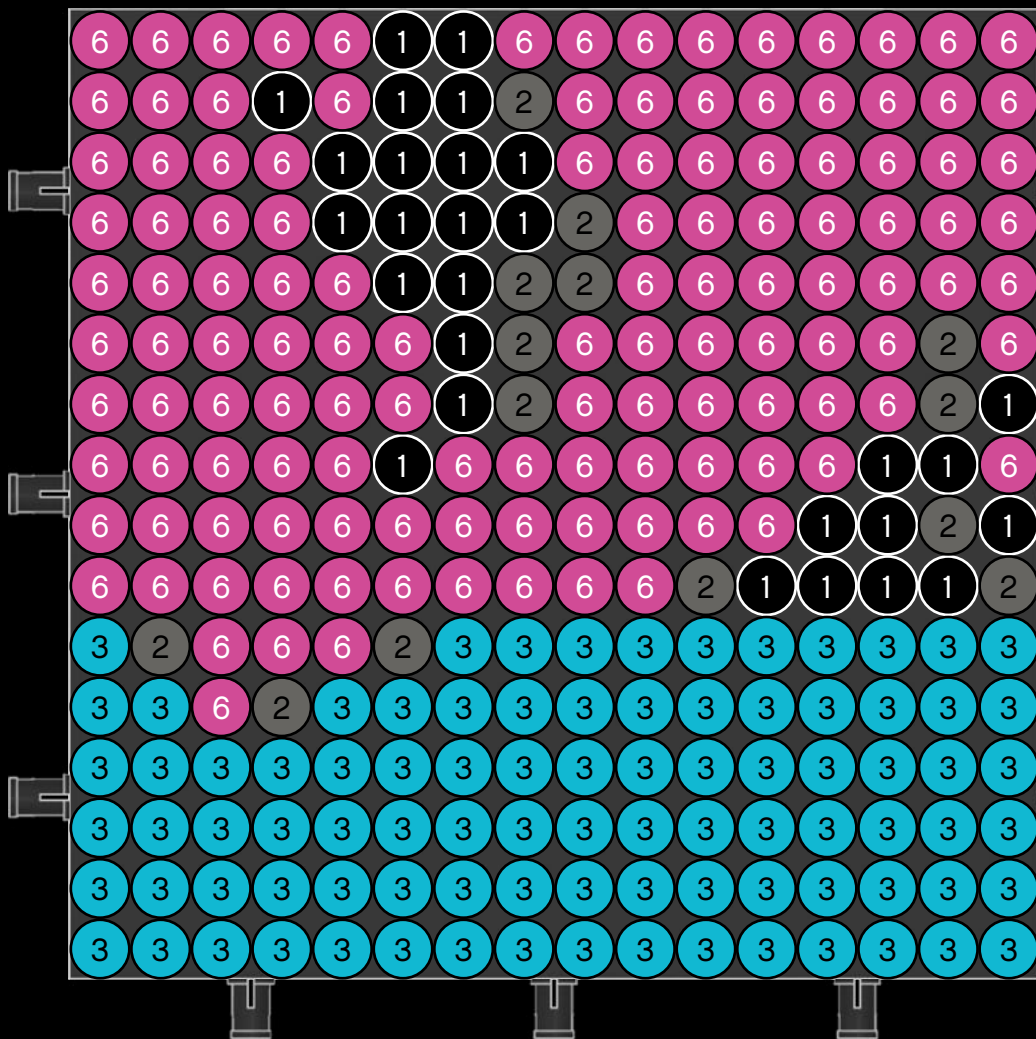
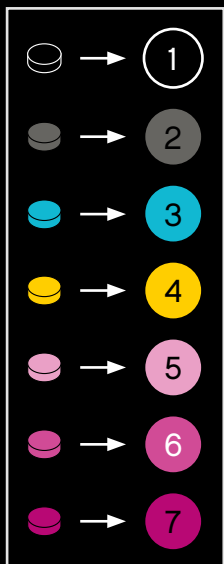

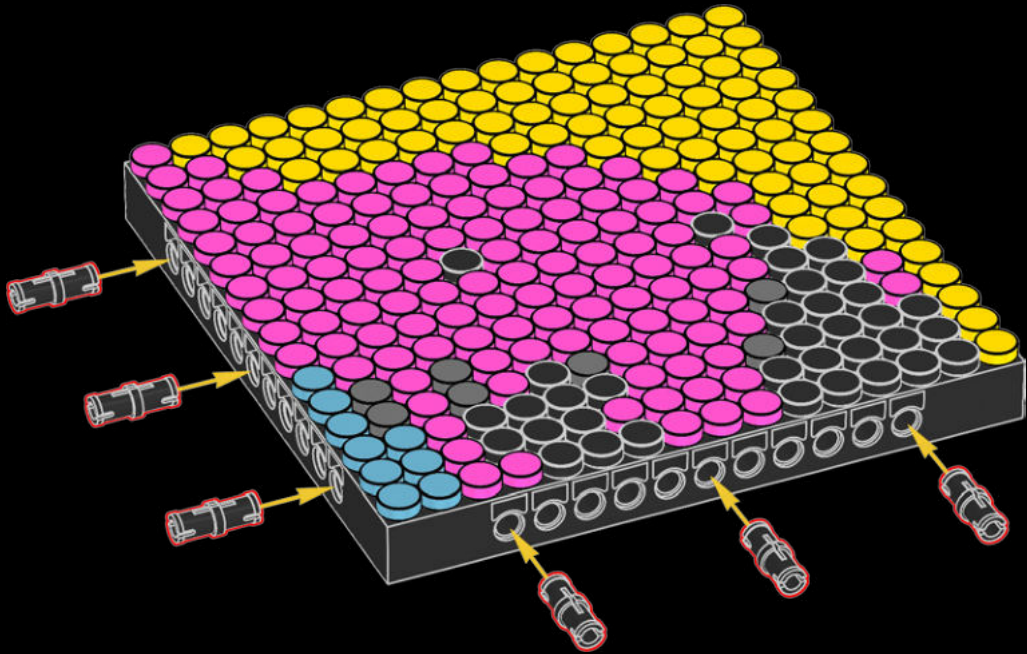

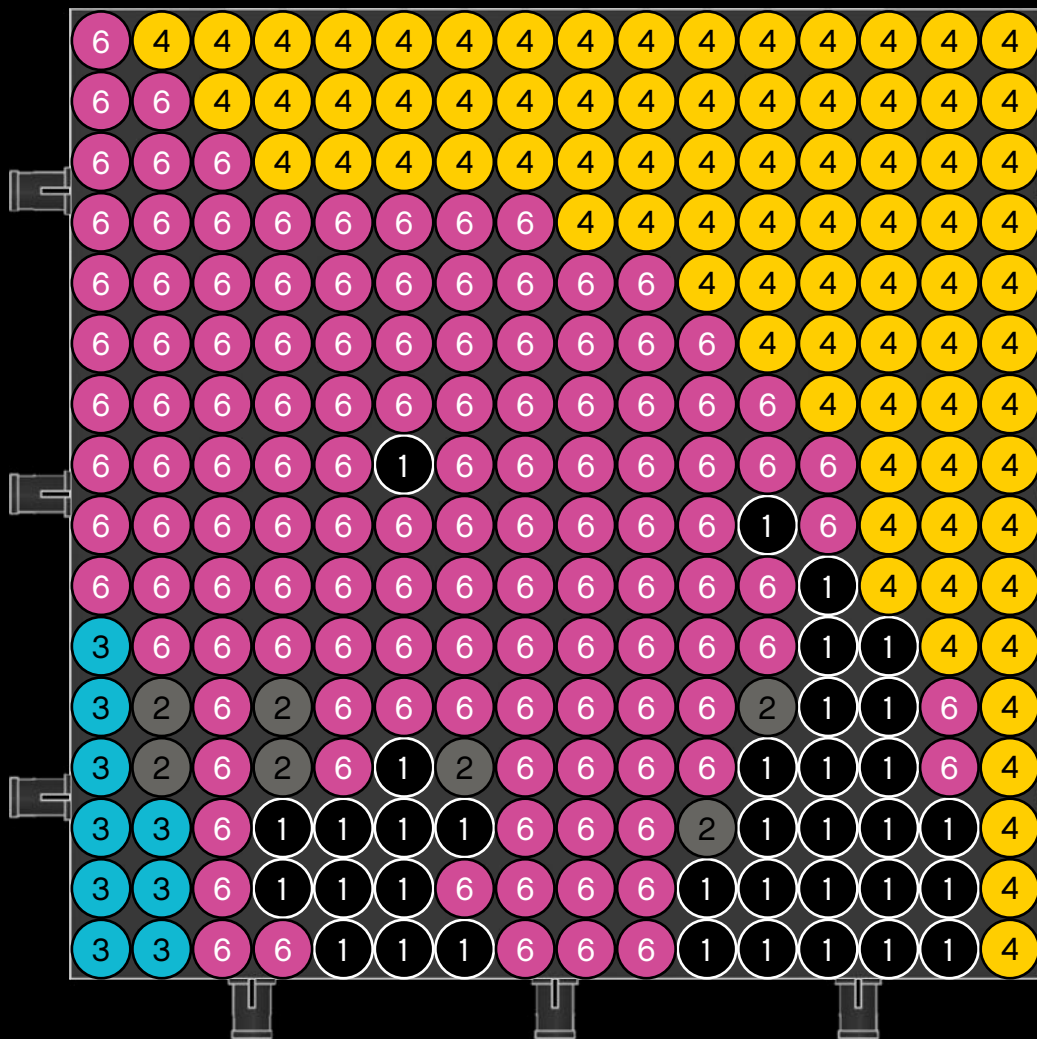
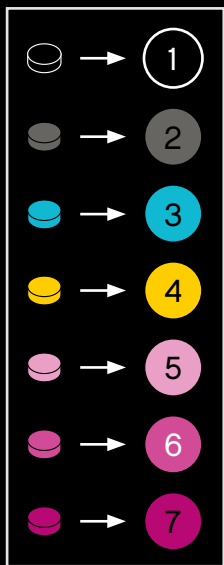

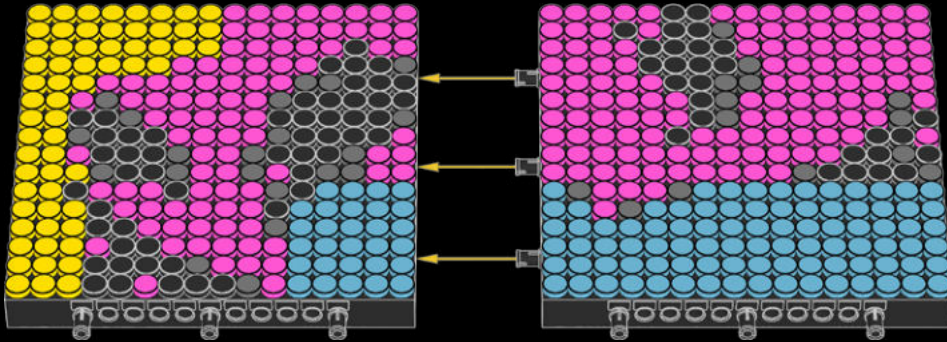

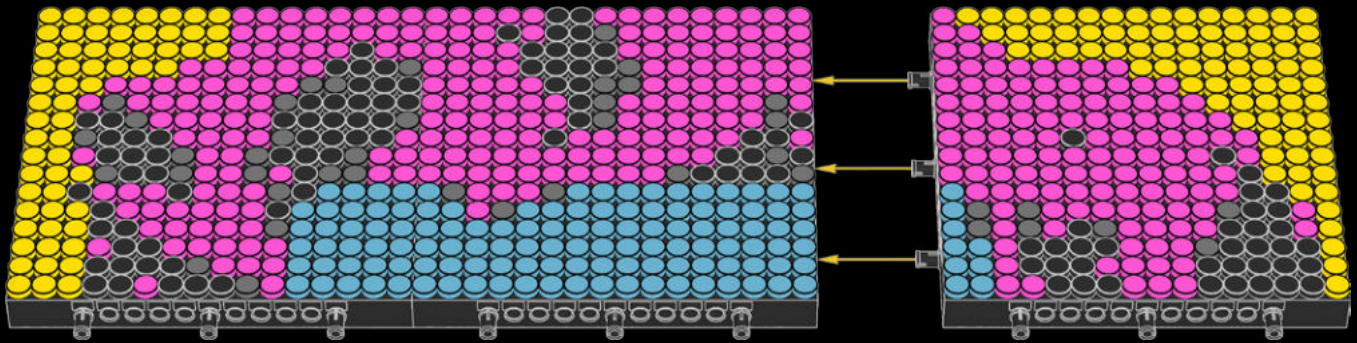

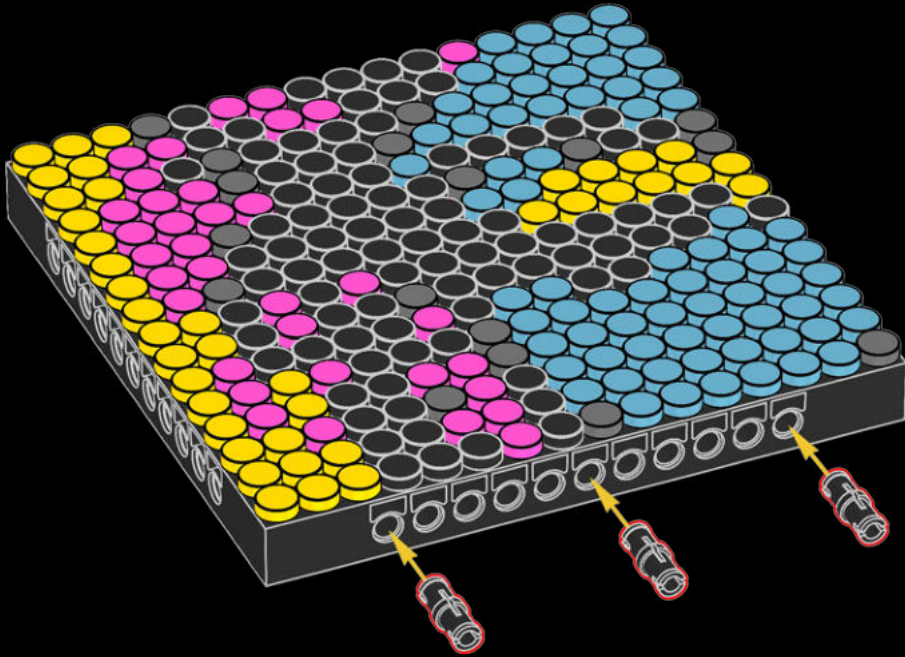



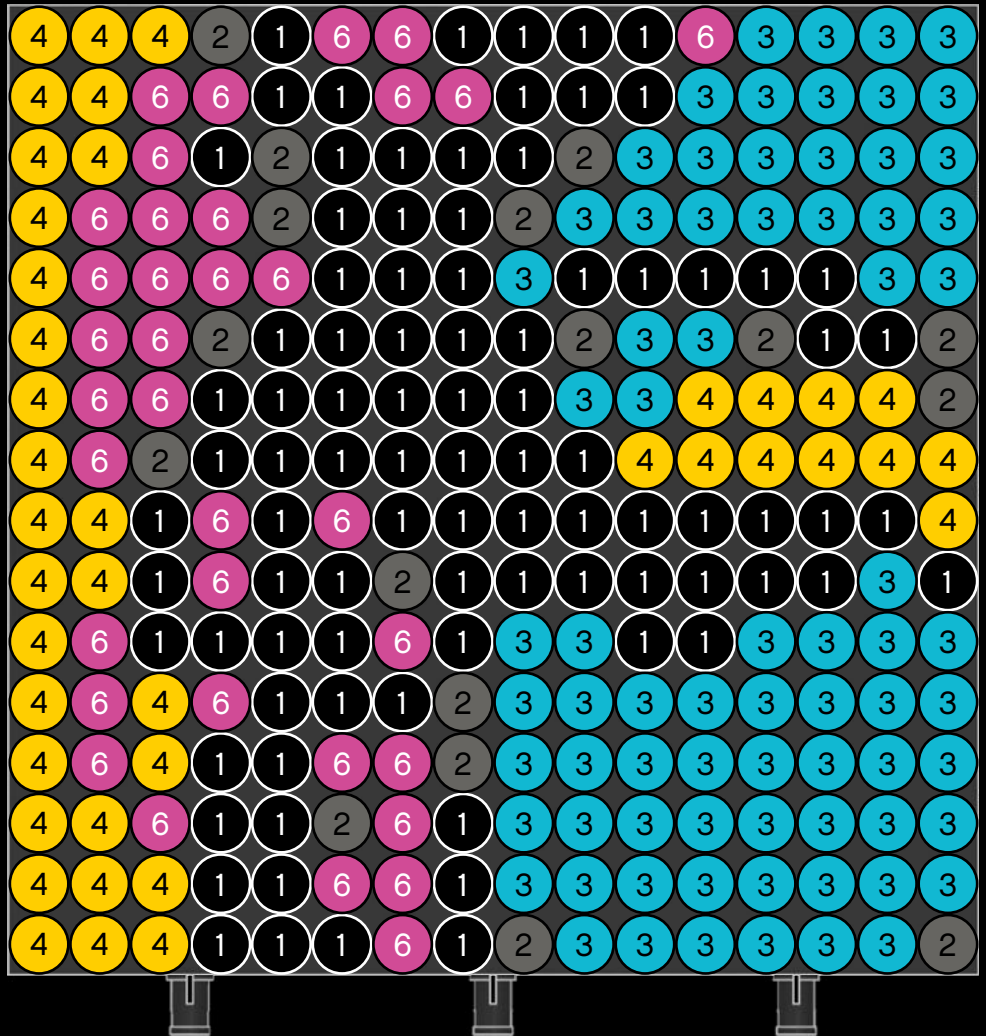
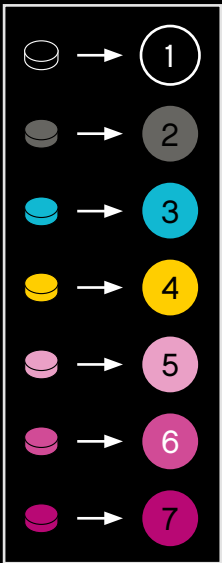

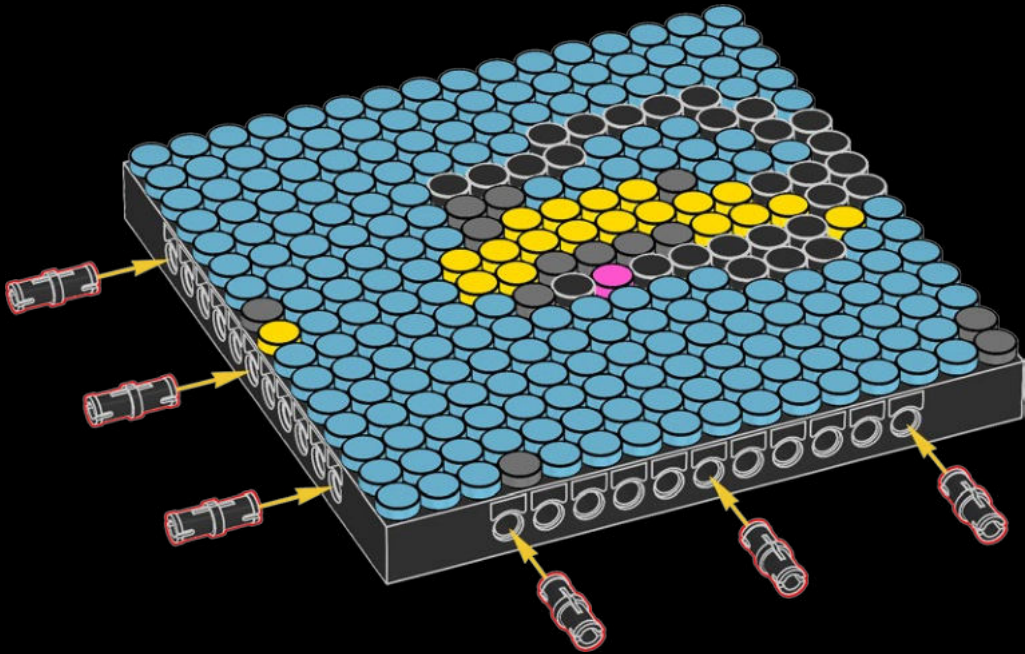
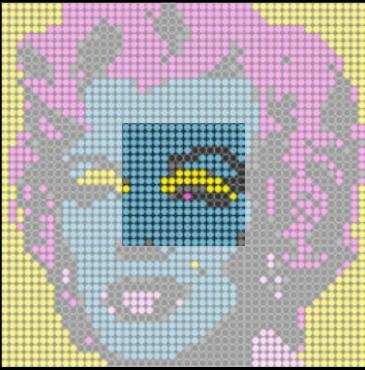

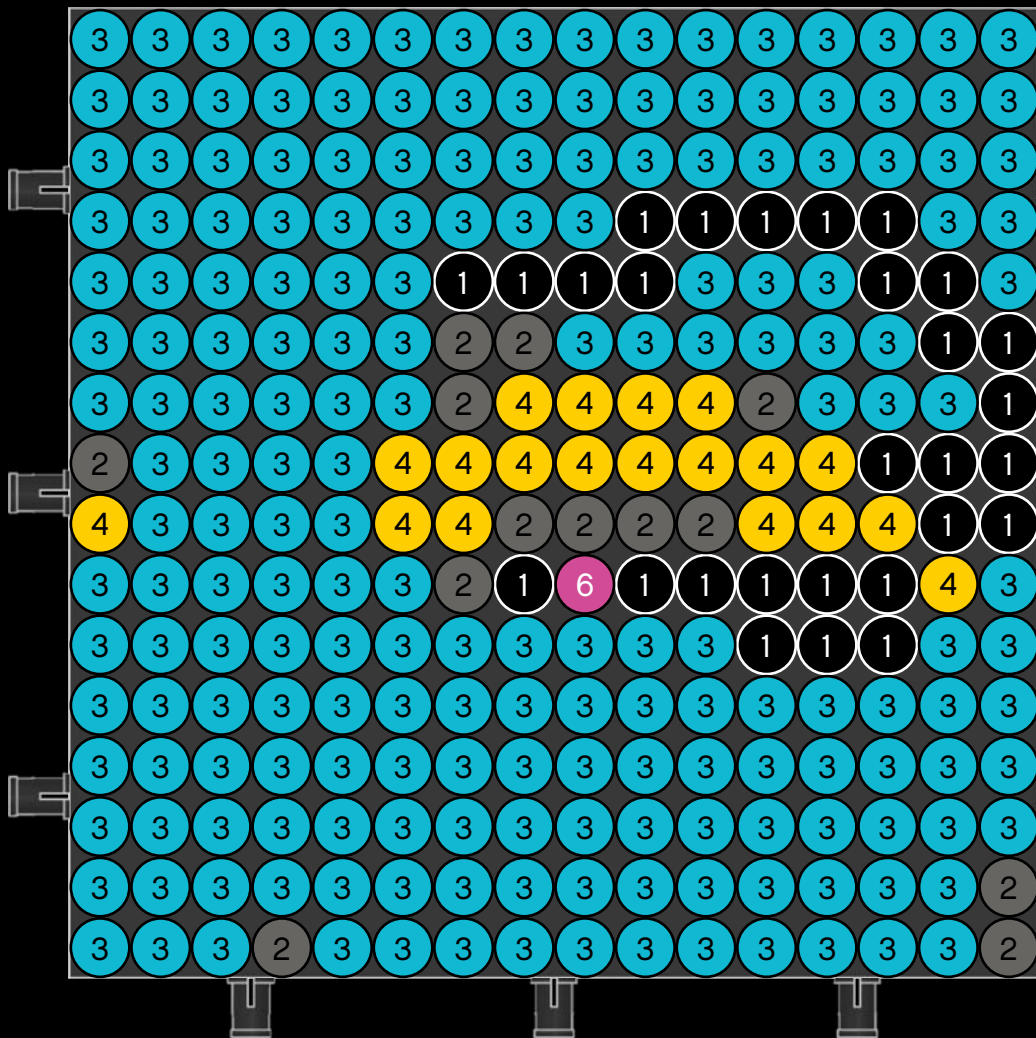
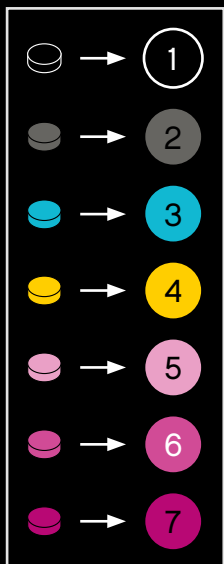

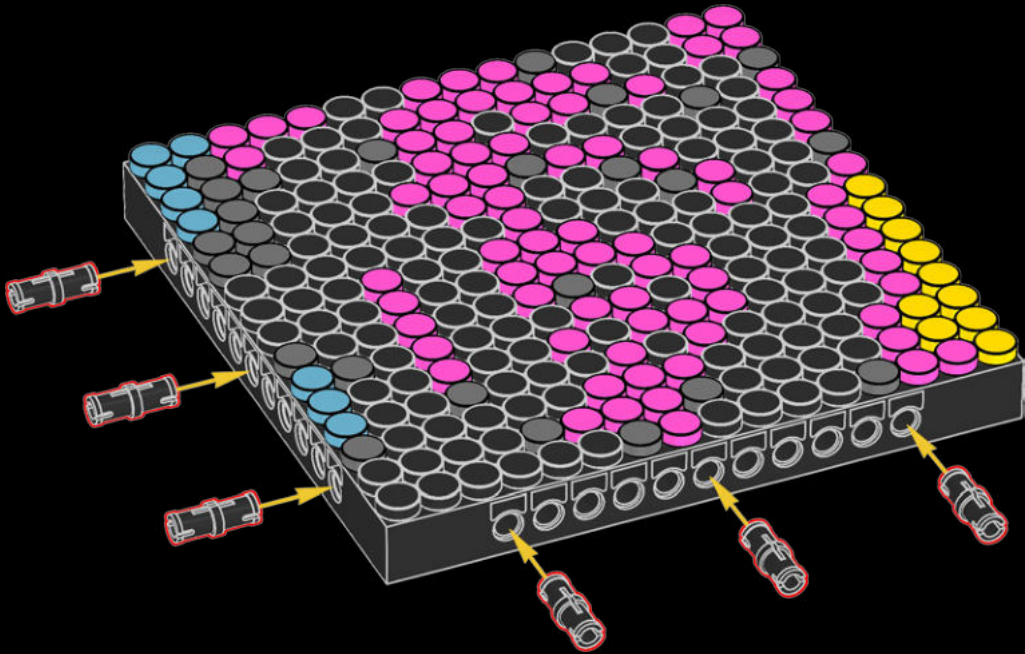

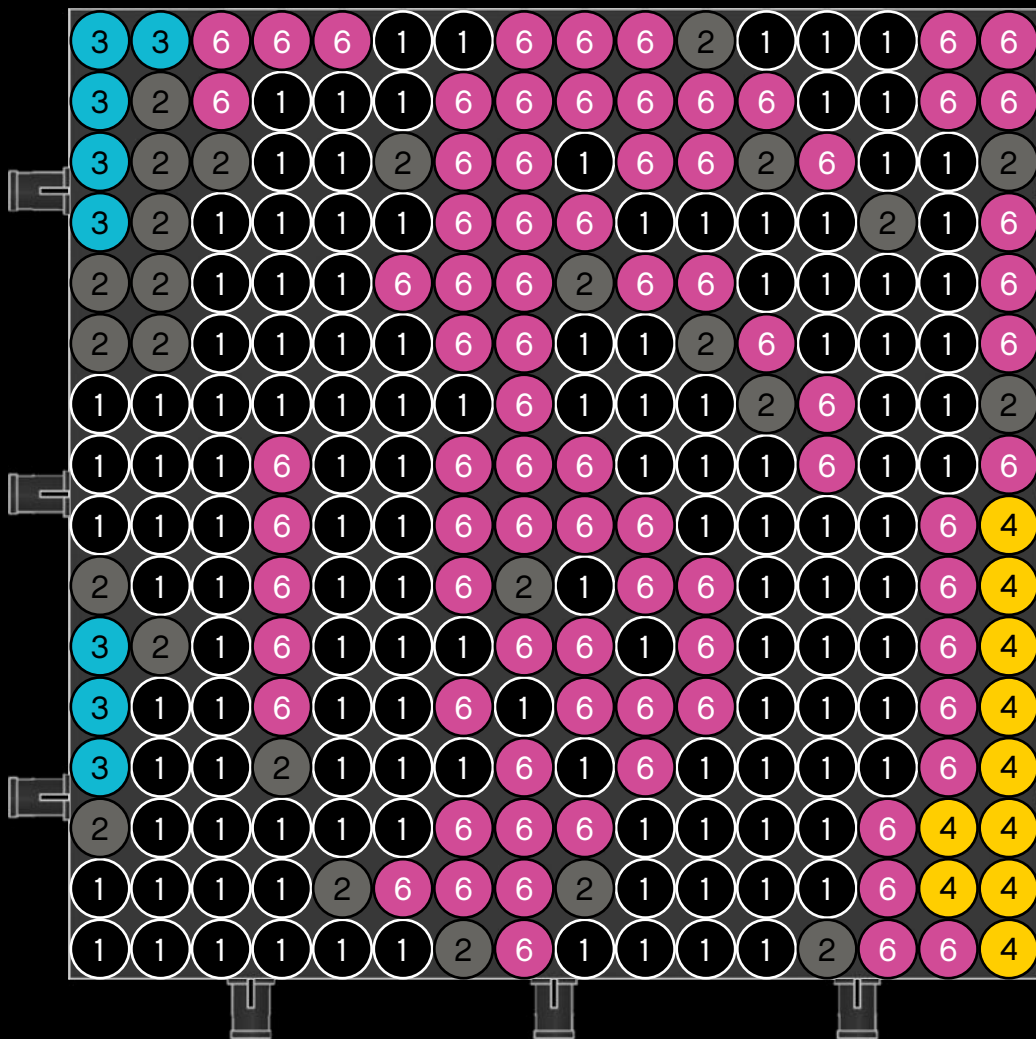
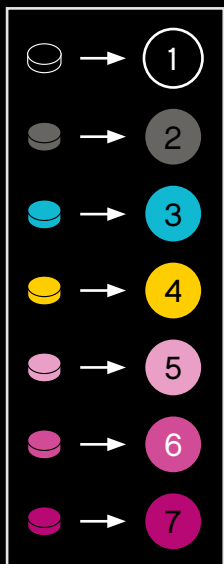

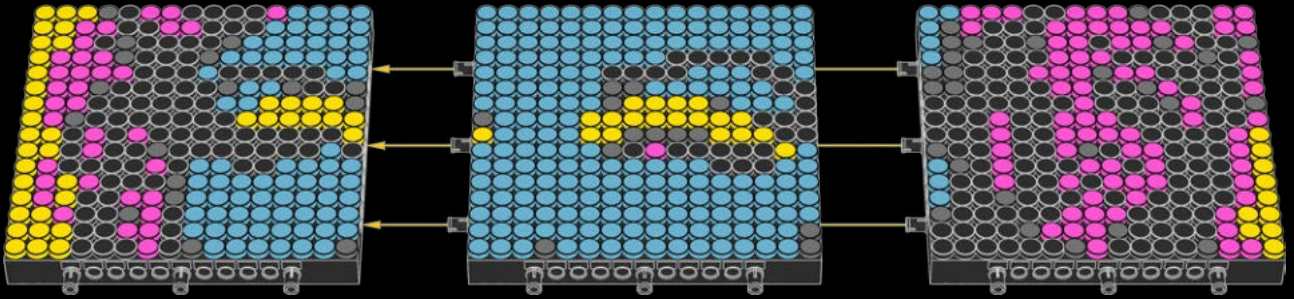

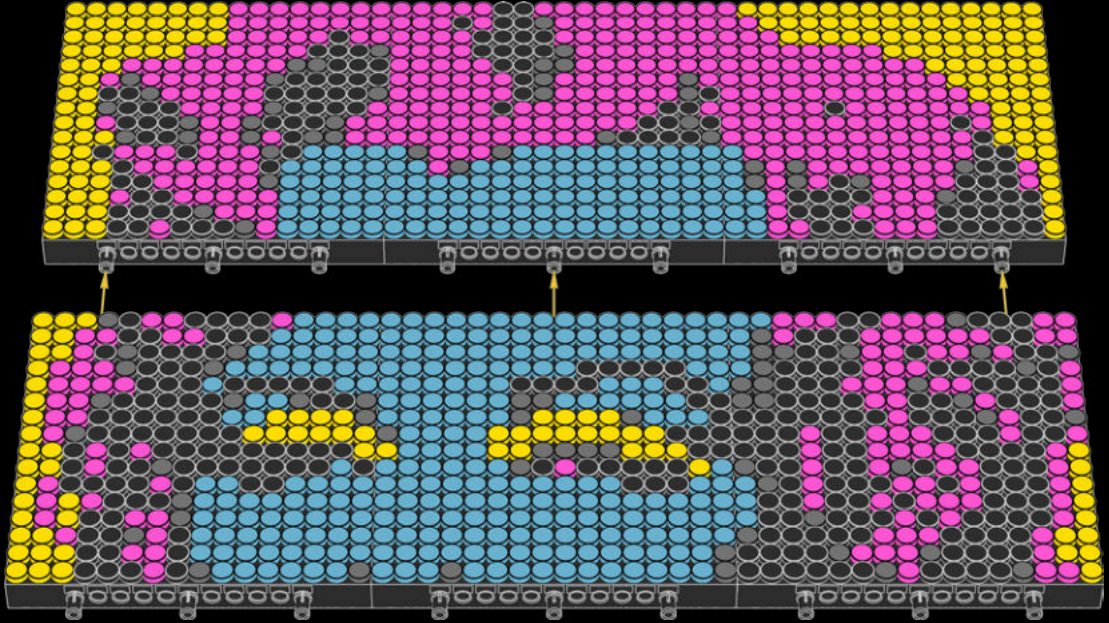

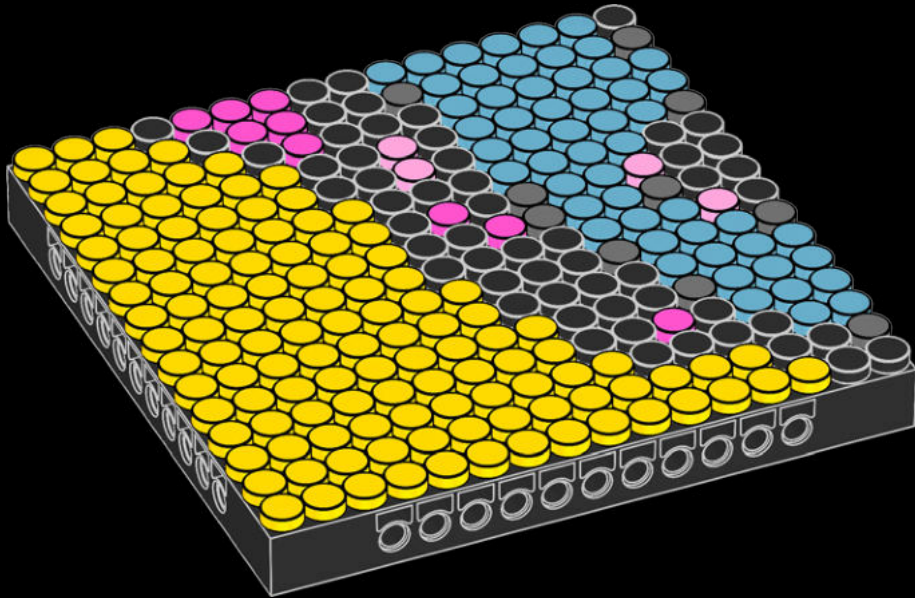



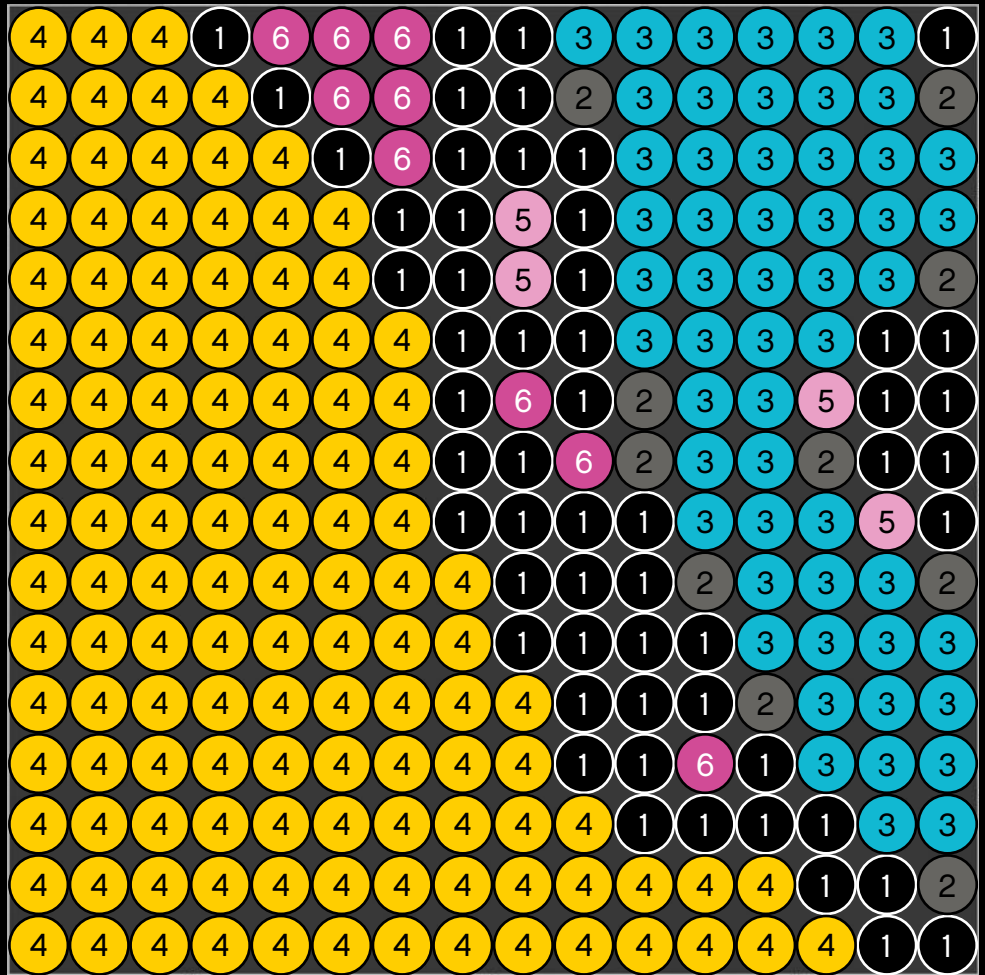
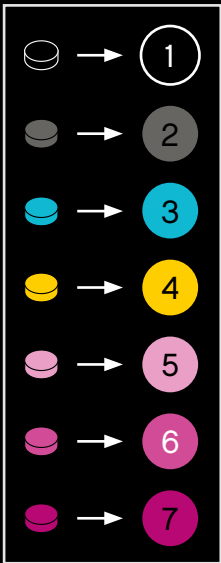

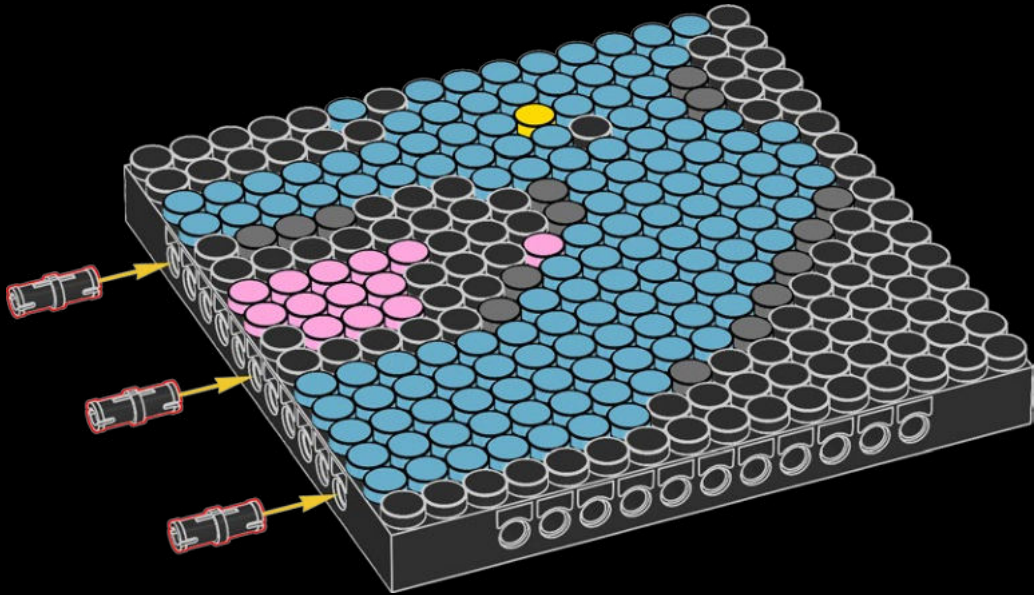

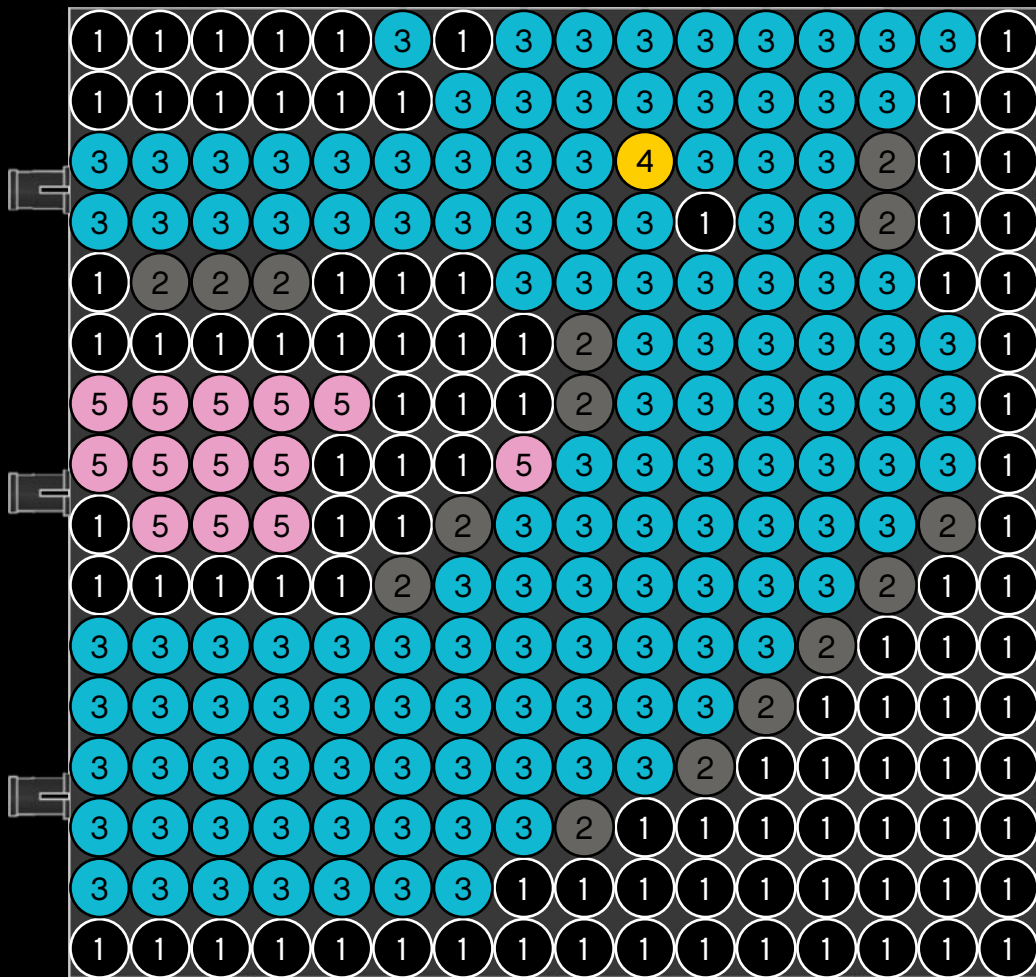
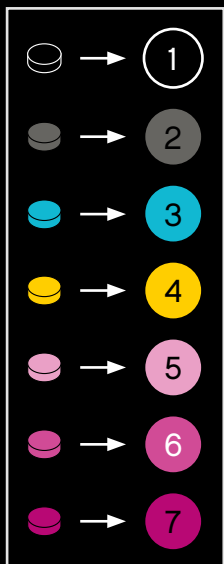

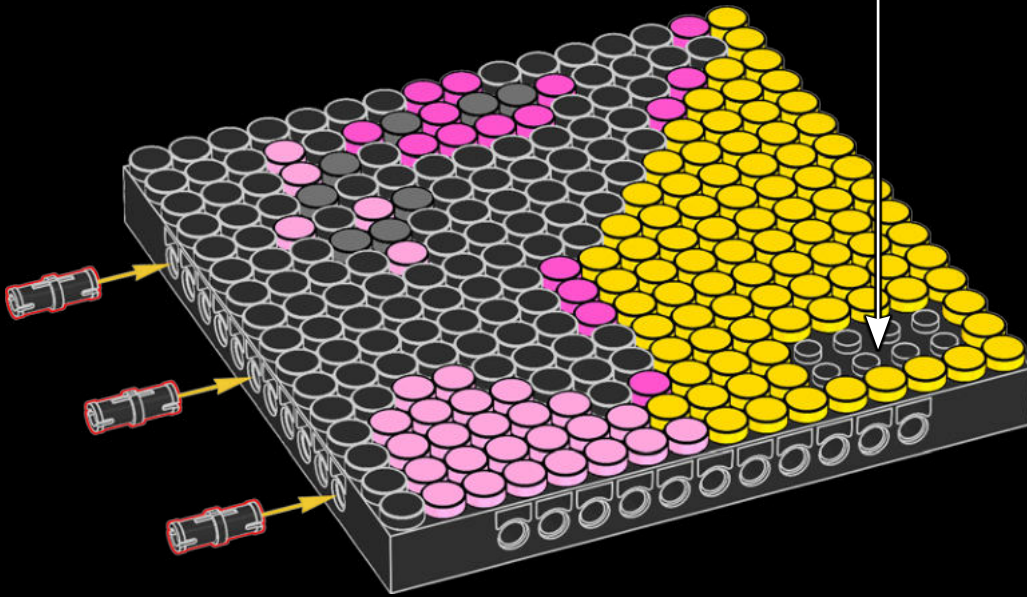
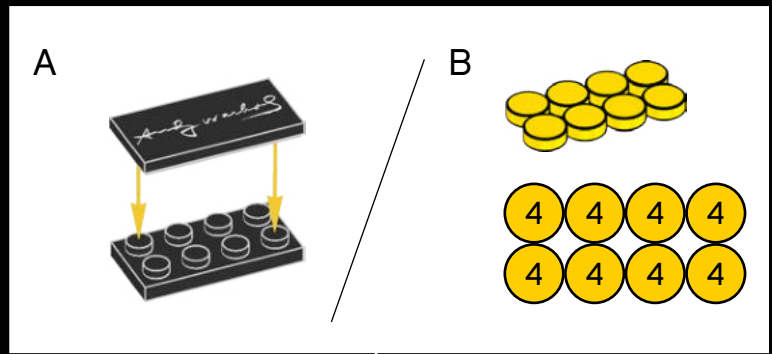

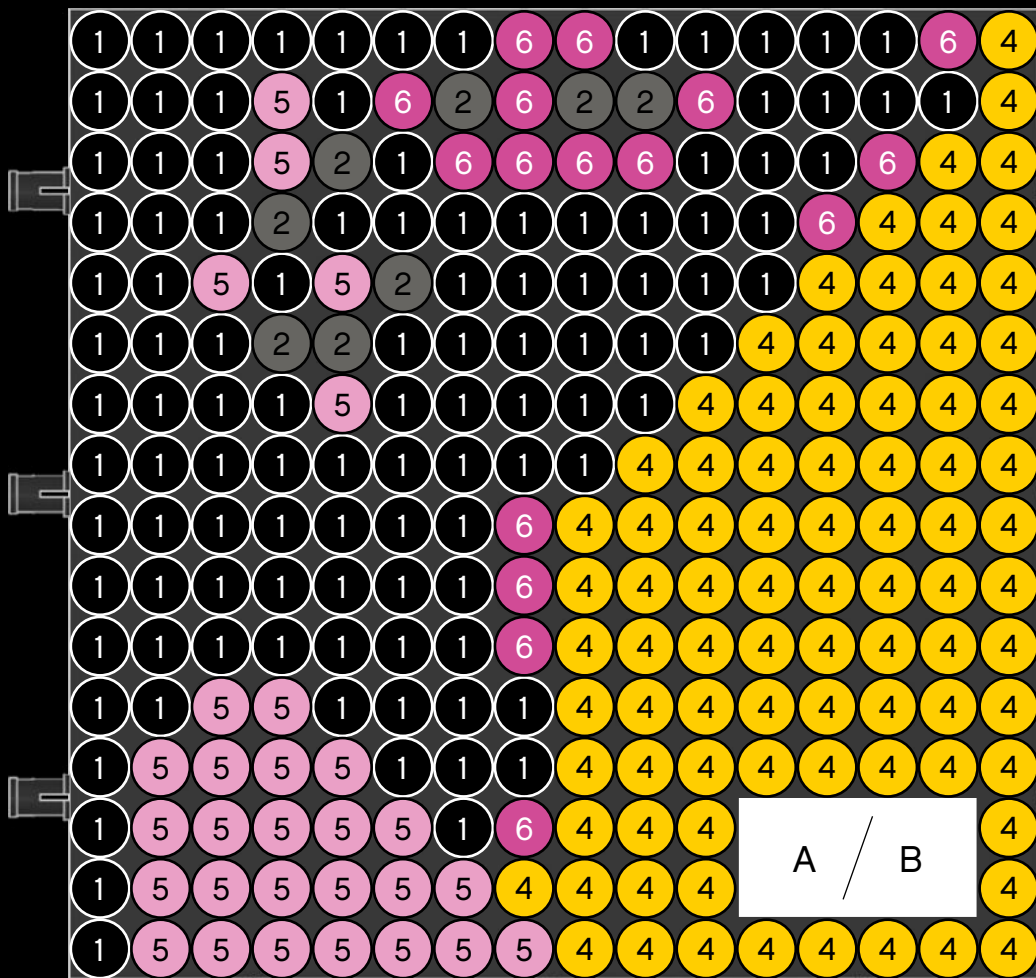
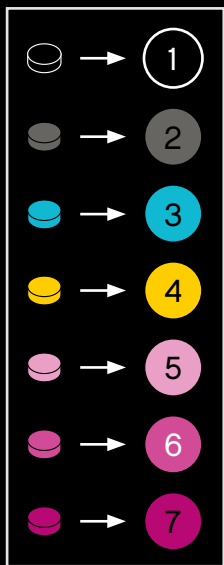

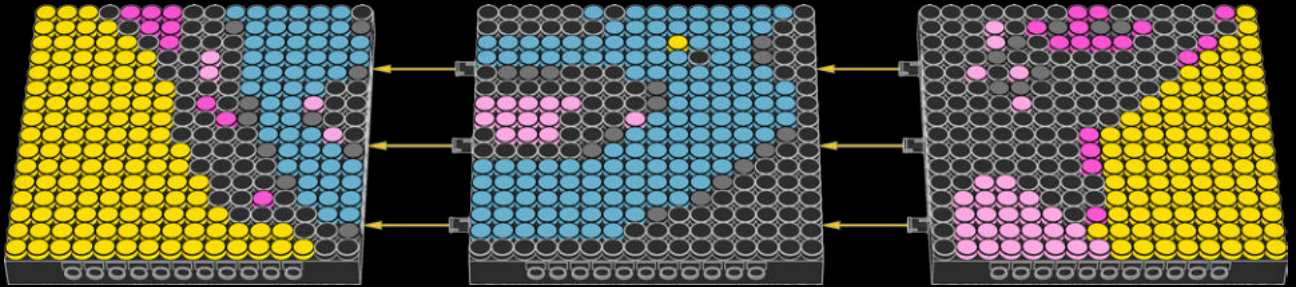

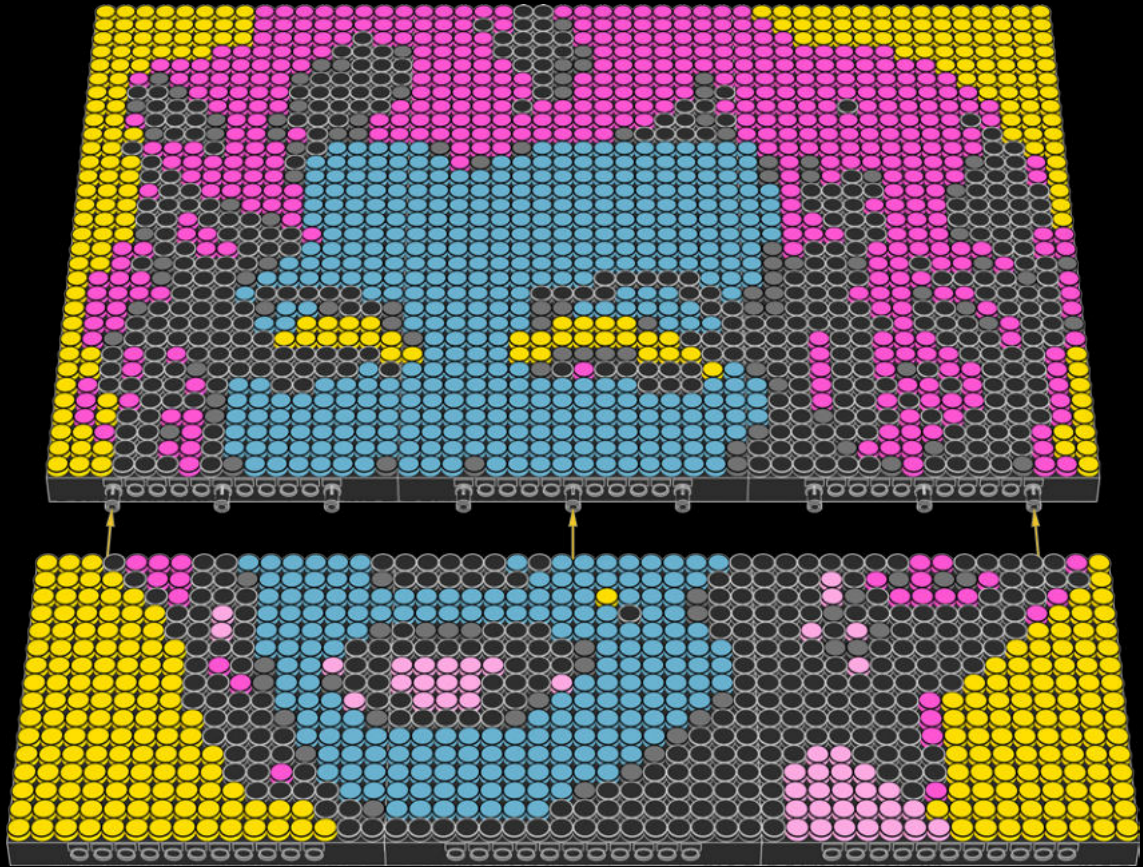

A



B



C



D

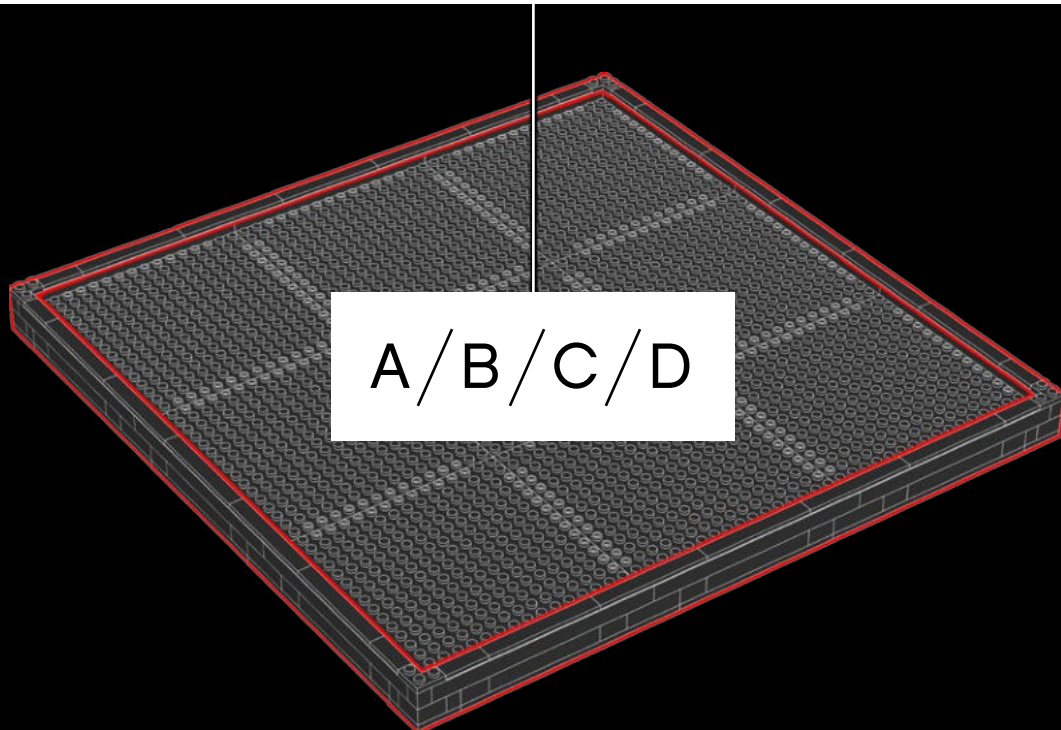



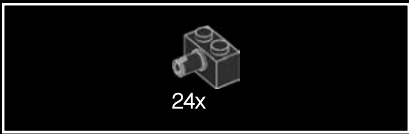

1

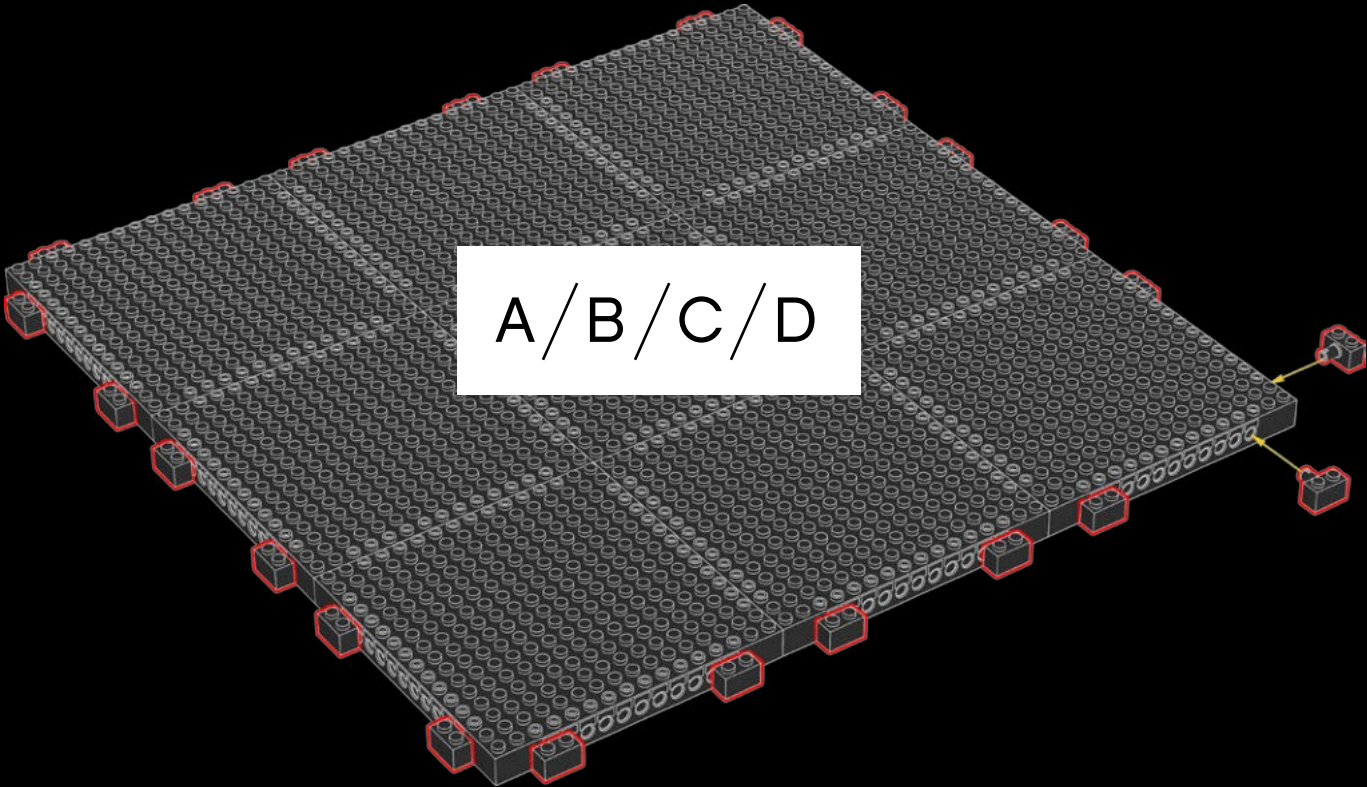

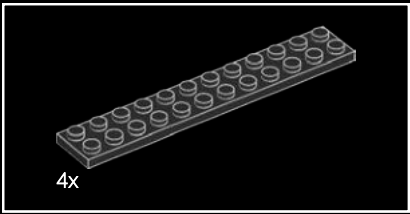

2

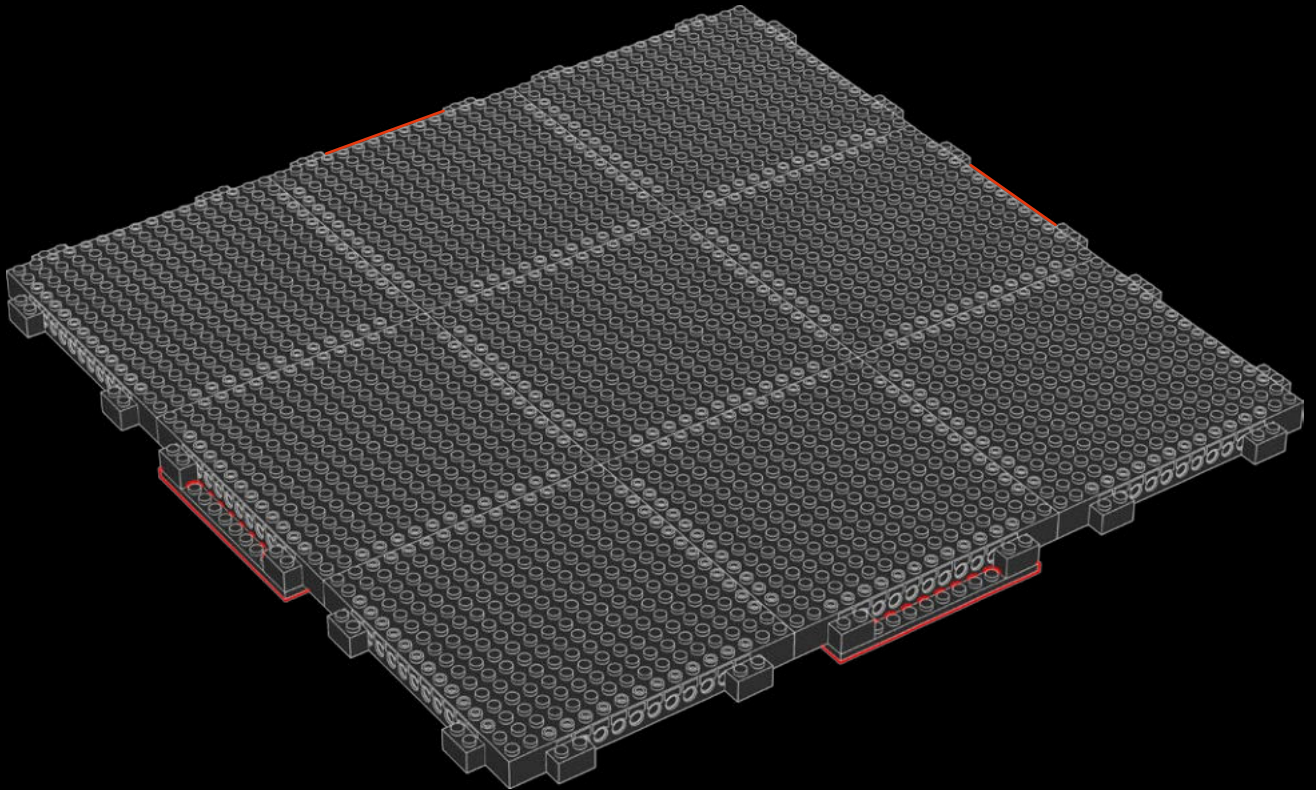

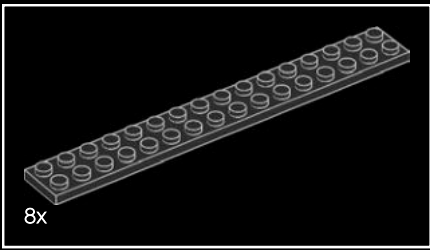

3

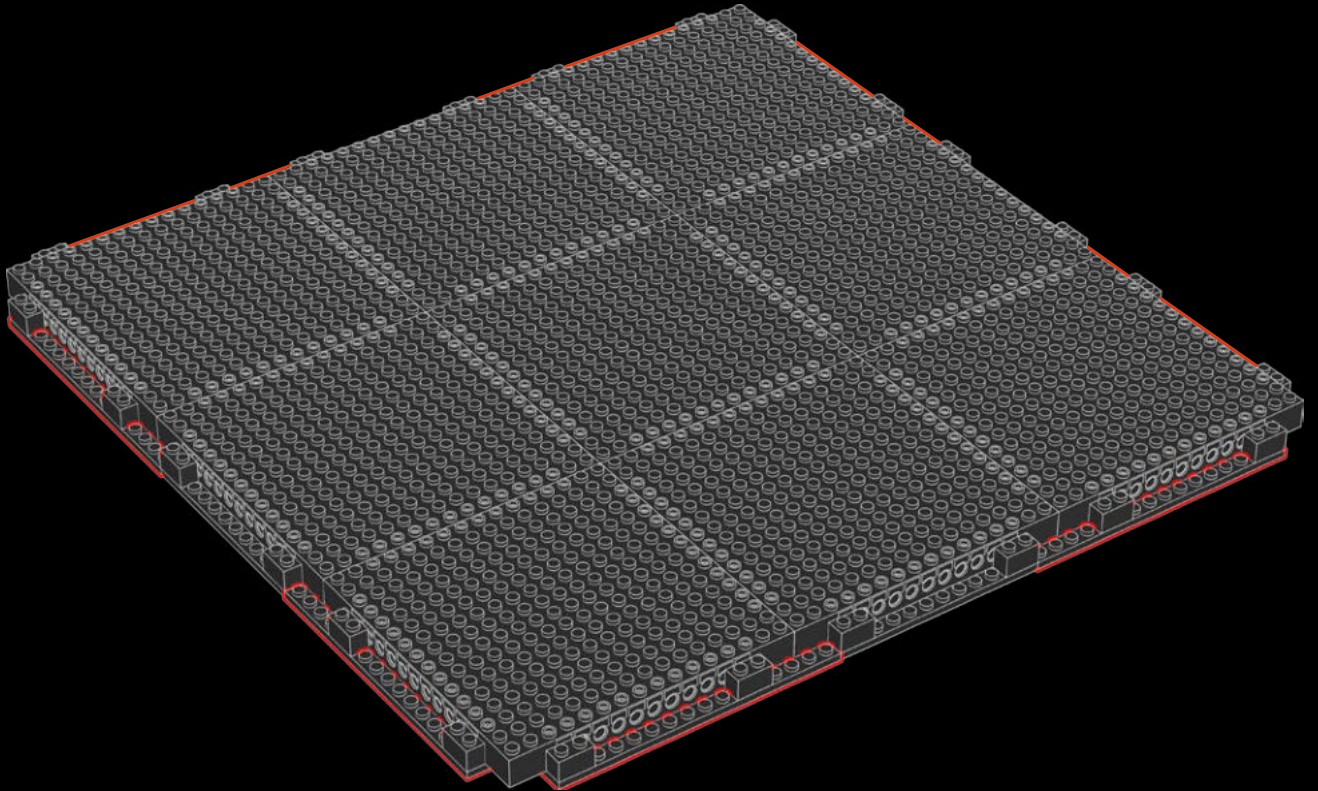

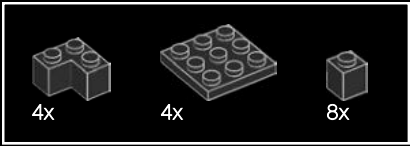

4

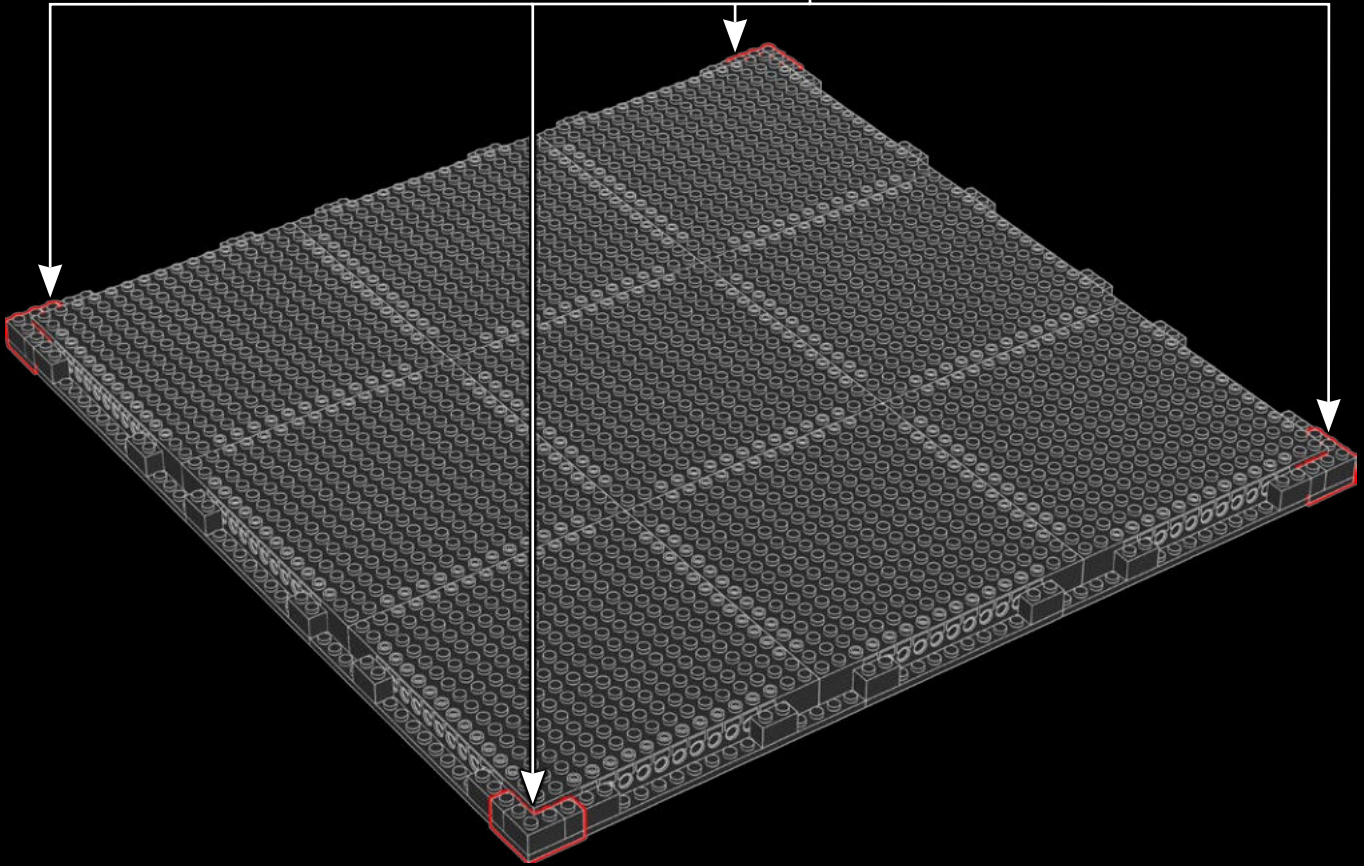
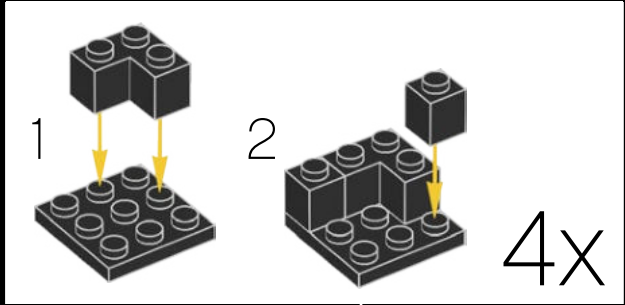

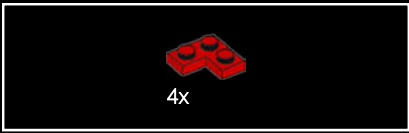

5

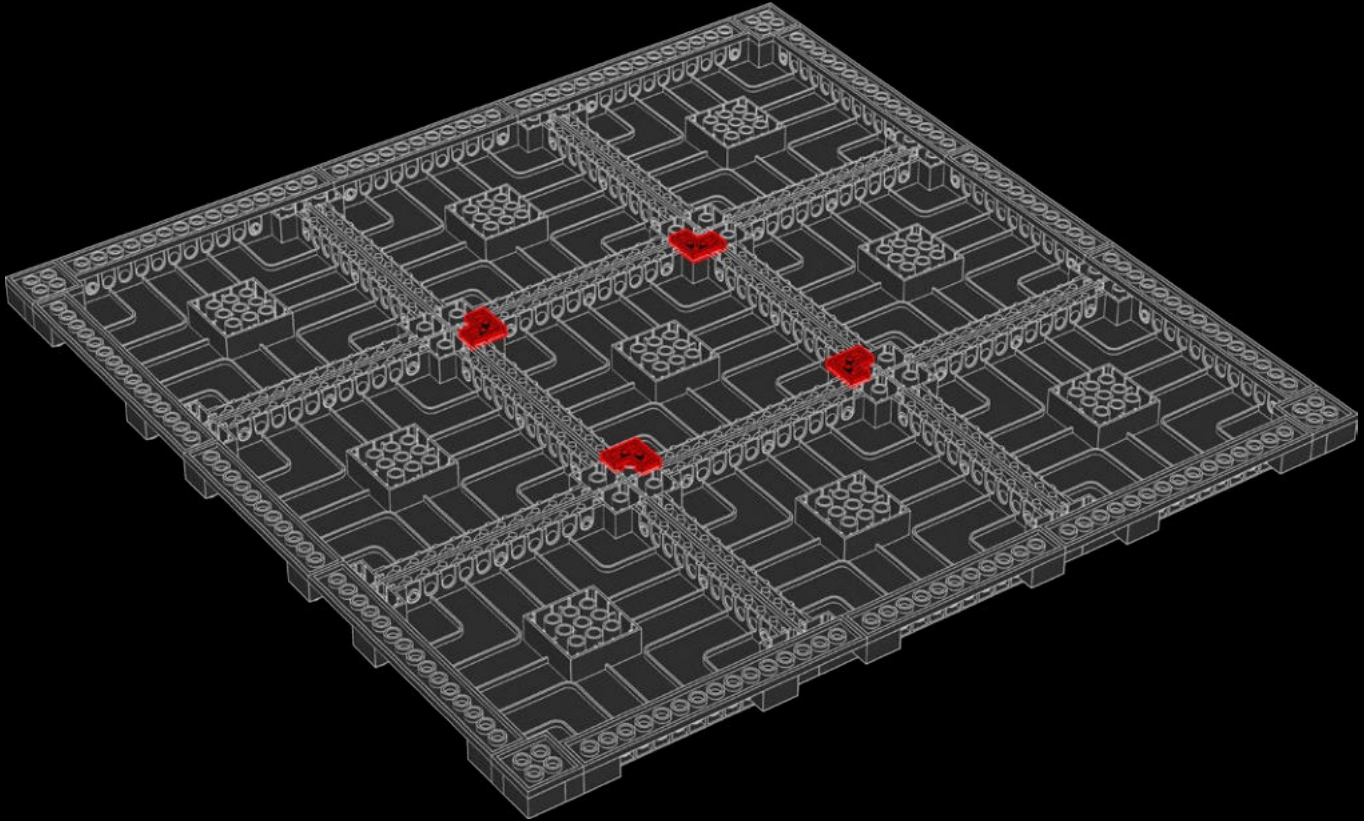



9x

6

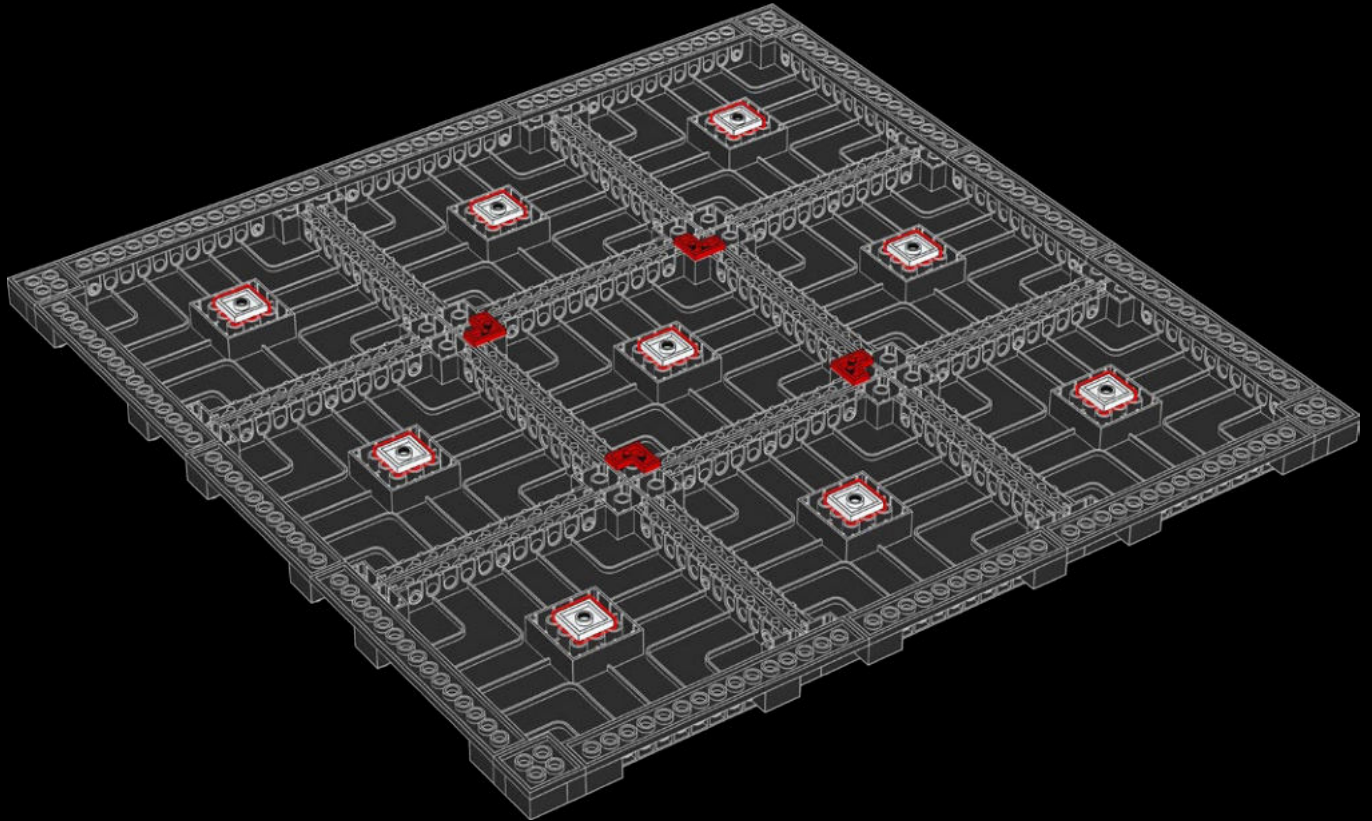

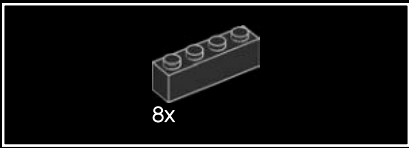

7

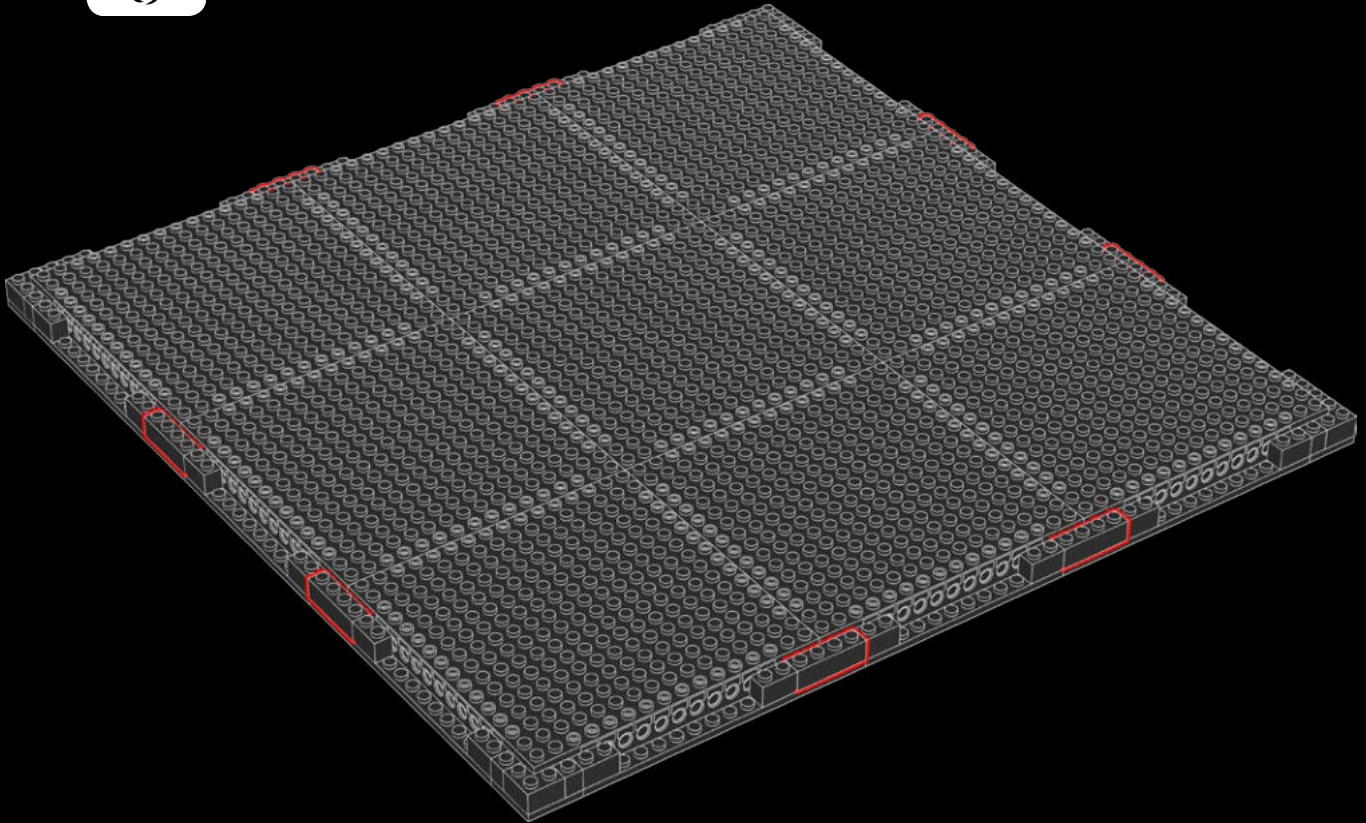

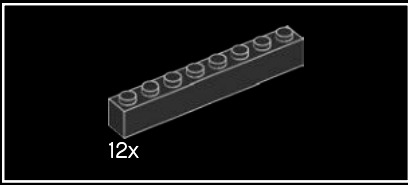

8

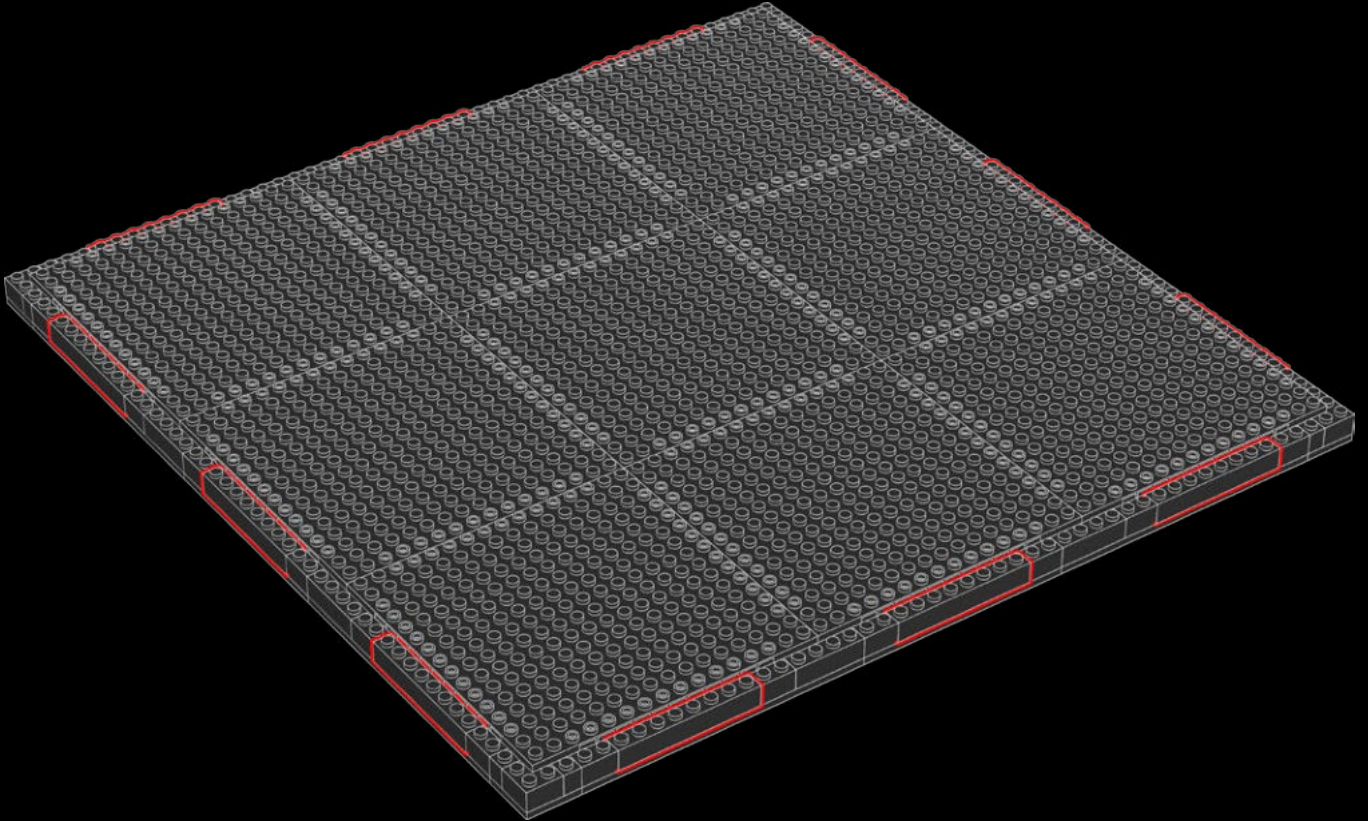



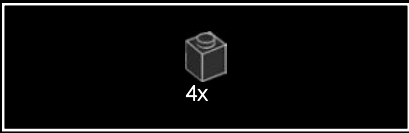

9

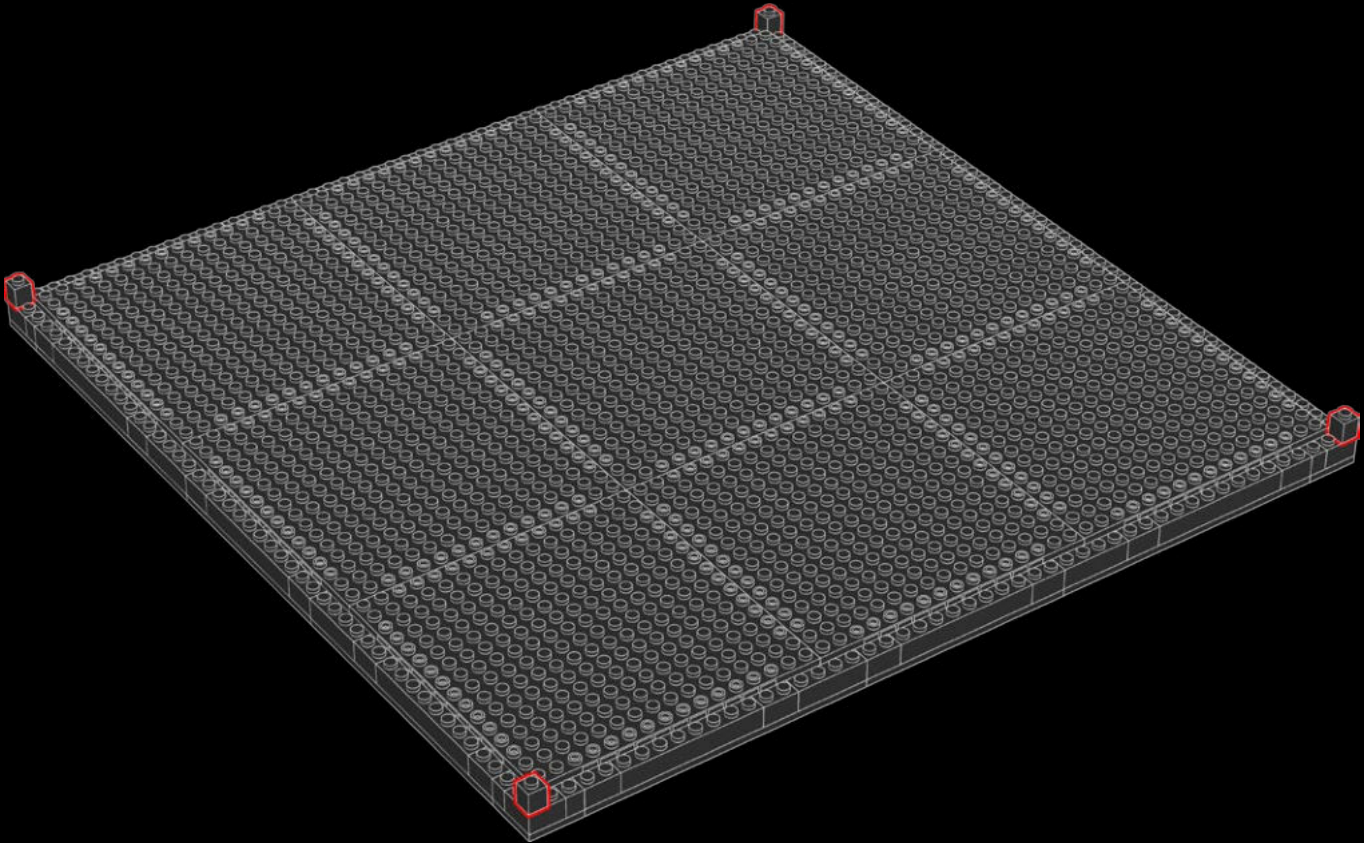

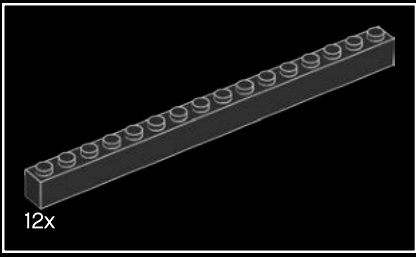

10

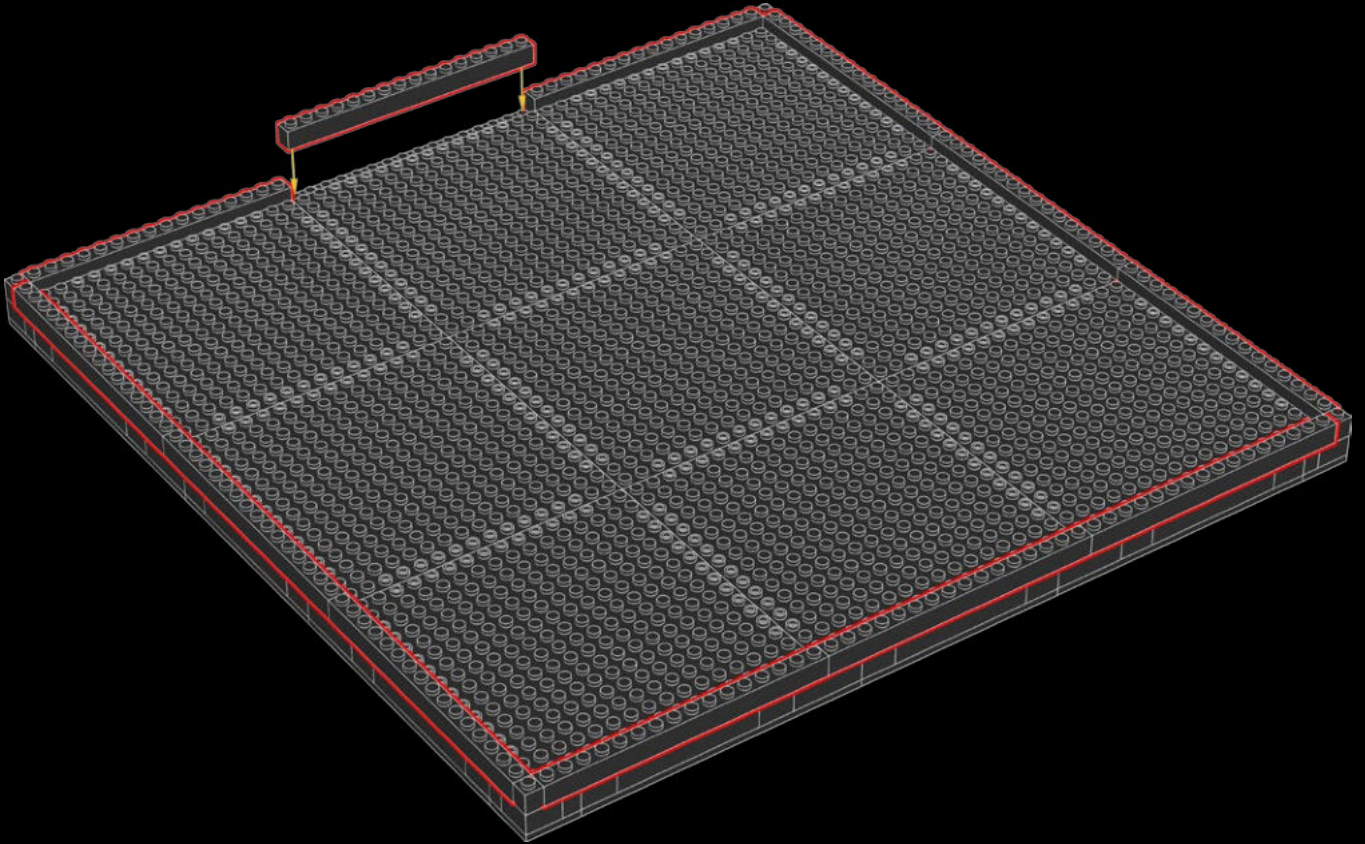

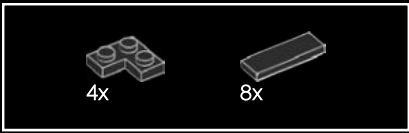

11

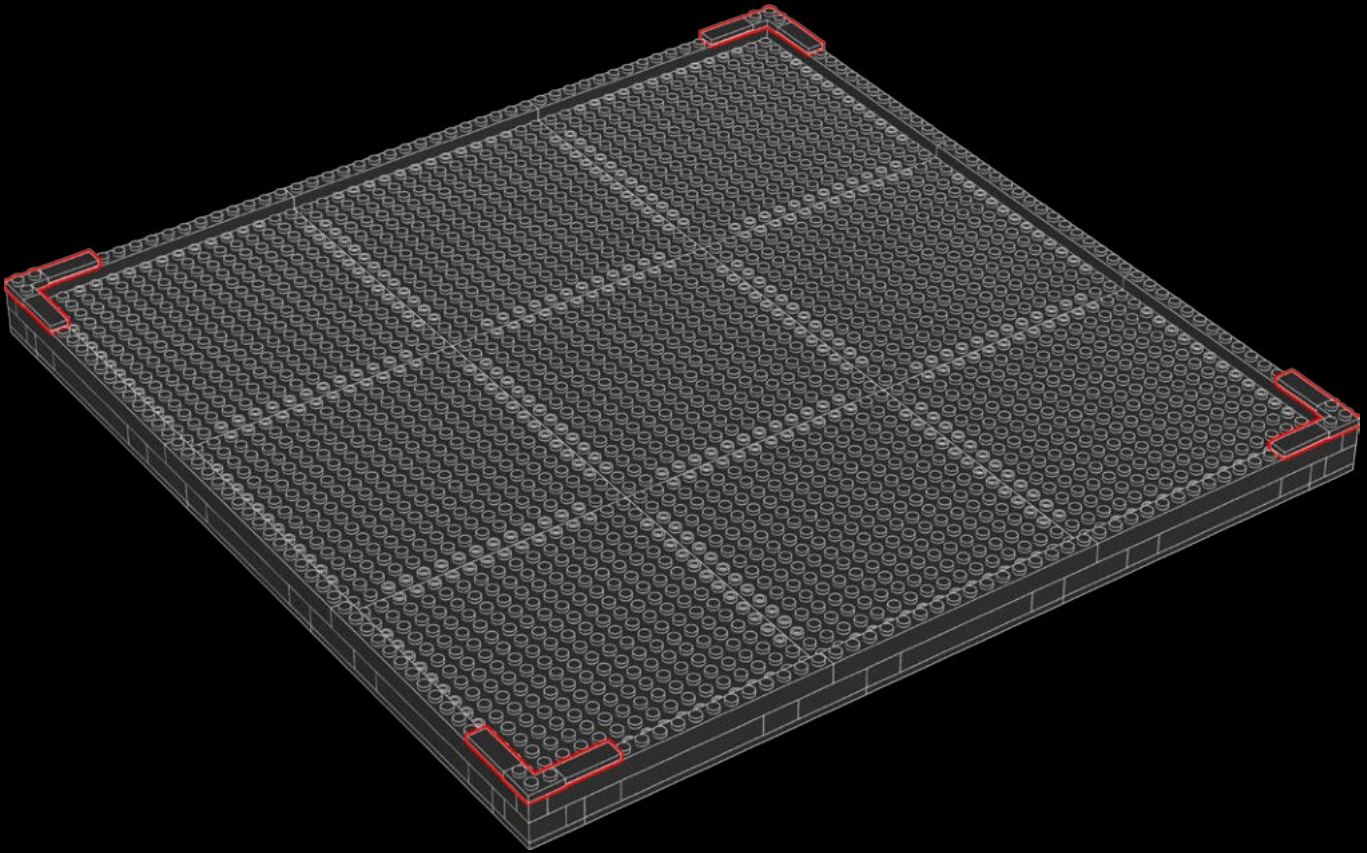

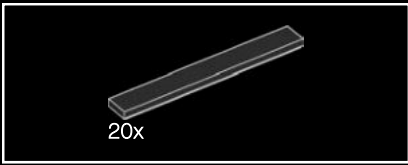

12

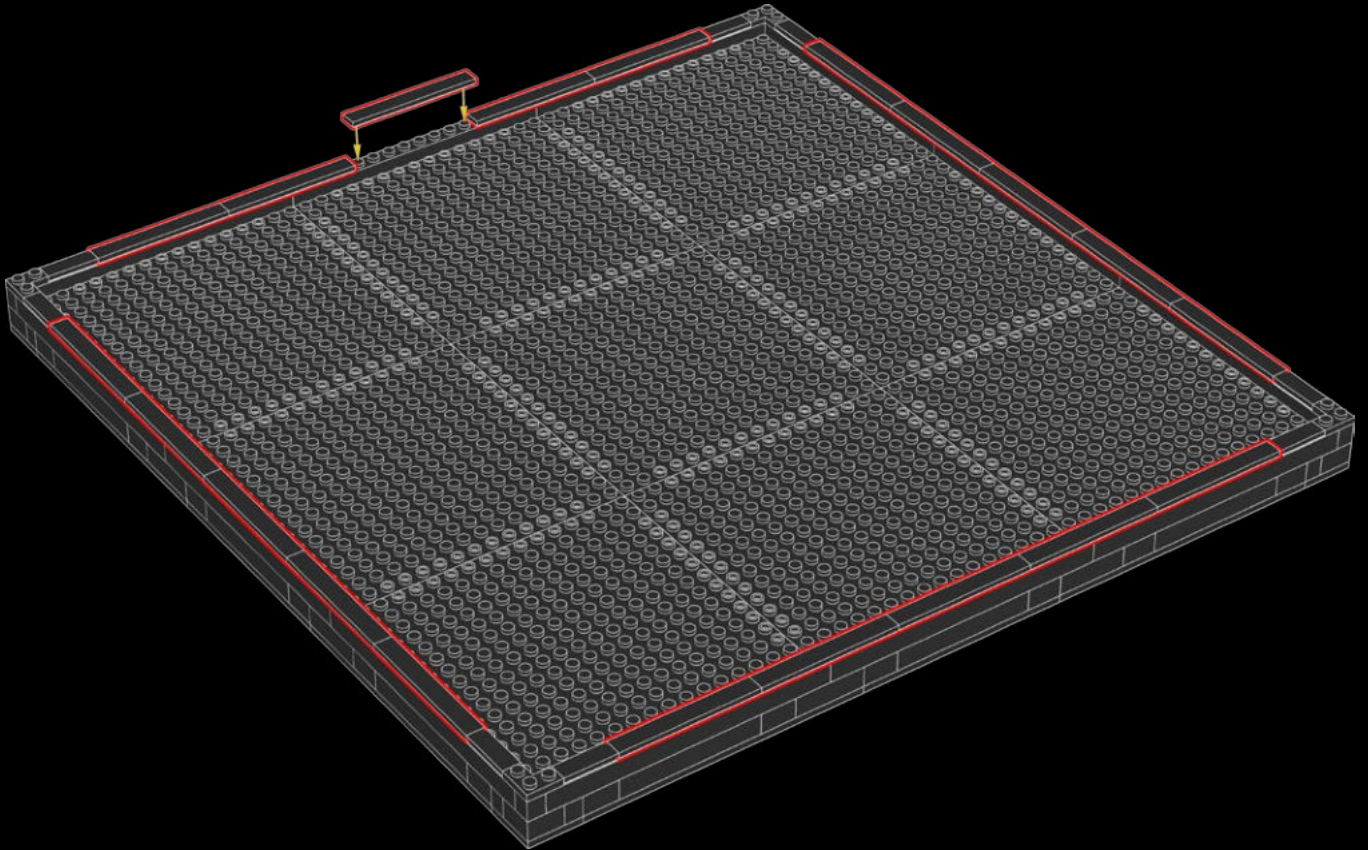

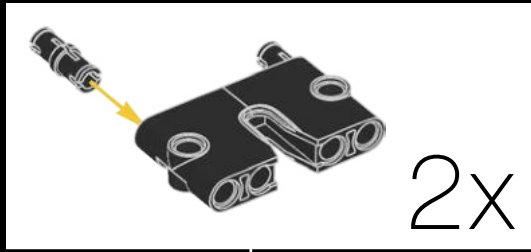
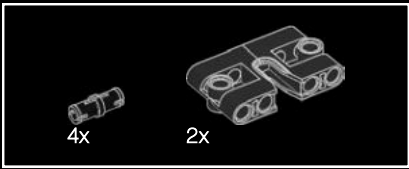

13

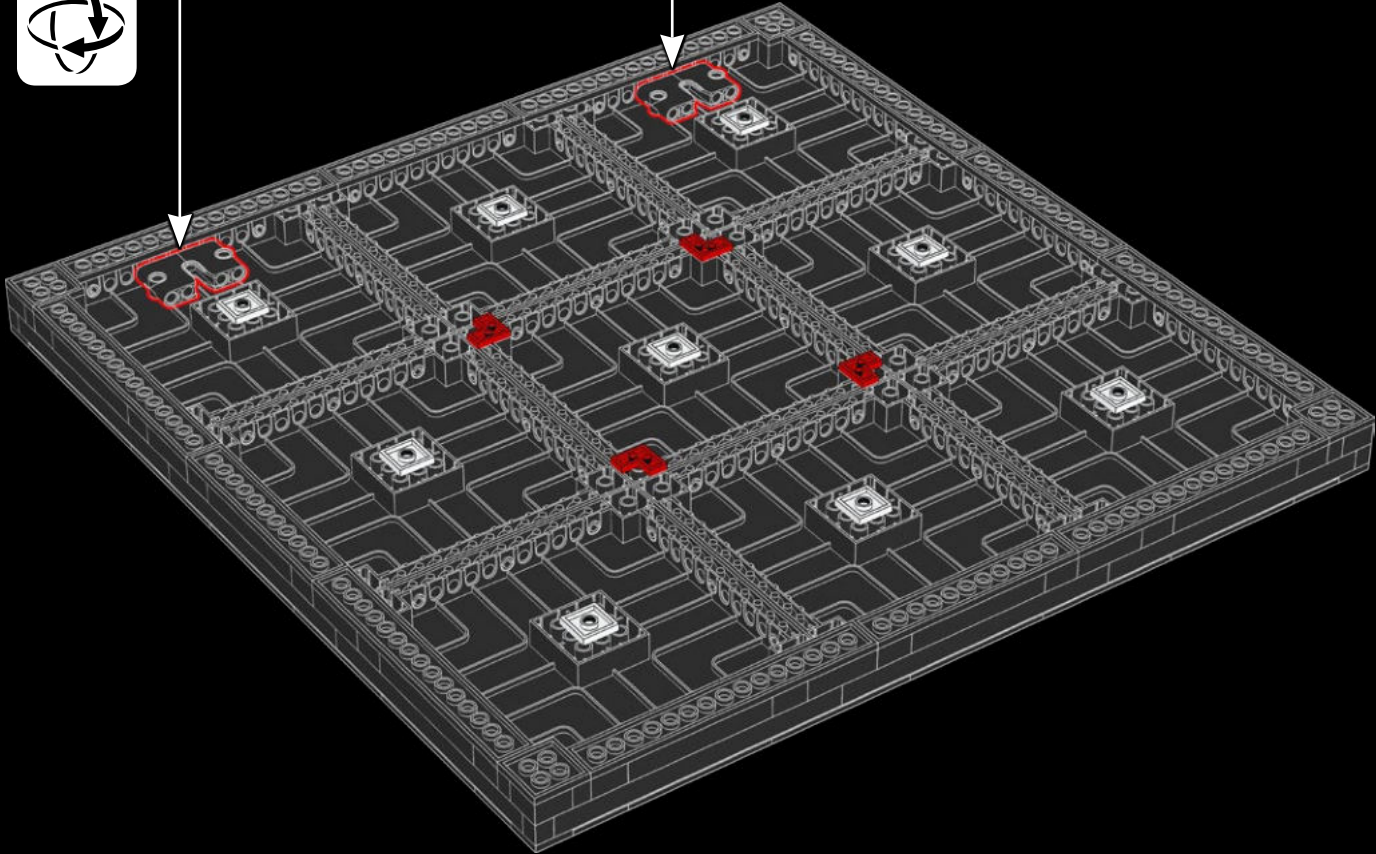







**WARHOL**

31197 Andy Warhol's Marilyn Monroe

**THE  
BEATLES**

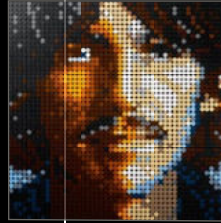

31198 The Beatles



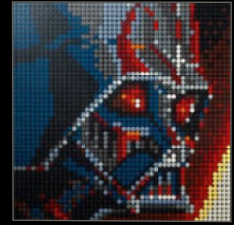

# THE SITH™

31200 *Star Wars™* The Sith™



# IRON MAN

31199 *Marvel Studios* Iron Man



# FEEDBACK AND WIN

## FEEDBACK AND WIN

Your feedback will help shape the future development of this product series.

Please visit:

## FEEDBACK UND GEWINNEN

Dein Feedback trägt zur Weiterentwicklung dieser Produktreihe bei.

Geh auf:

## COMMENTEZ ET GAGNEZ

Vos commentaires nous aideront à concevoir les futurs produits de cette gamme.

Rendez-vous sur :

## COMENTA Y GANA

Tu opinión nos ayudará a dar forma al desarrollo de esta serie de productos en el futuro.

Visita:

## 反馈有奖

您的反馈将有助于我们在今后改进本系列产品。

请访问：

[LEGO.com/productfeedback](https://www.lego.com/productfeedback)

By completing, you will automatically enter a drawing to win a LEGO® set.

Terms & Conditions apply.

Durch Ausfüllen nimmst du automatisch an der Verlosung eines LEGO® Preises teil.

Es gelten die Teilnahmebedingungen.

En envoyant vos commentaires, vous serez automatiquement inscrit(e) à un tirage au sort qui vous permettra de remporter un prix LEGO®.

Offre soumise à conditions.

Al contestar, participarás automáticamente en el sorteo y podrás ganar un set LEGO®.

Sujeto a Términos y Condiciones.

完成我们的反馈调查，即可自动进入抽奖环节，赢取乐高®套装。

适用《条款和条件》。

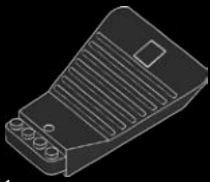

1x  
6302093

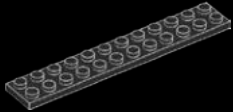

4x  
244526

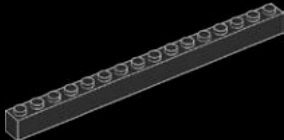

12x  
246526

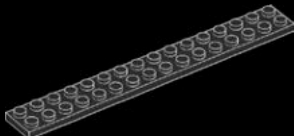

8x  
428226

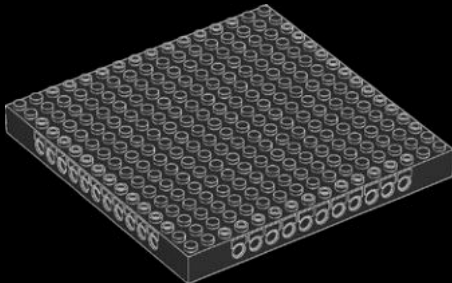

9x  
6302092



4x  
6174917



1x  
302026



1x  
6316462



8x  
301026

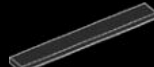

20x  
416226

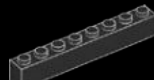

12x  
300826



2x  
6302094



12x  
300526



40x  
4121715



24x  
6116990



4x  
242026



4x  
235726



8x  
4558170



9x  
302201



4x  
242021



587x  
6284577



629x  
6284070



131x  
6284596



46x  
6322816



587x  
6322821



587x  
6284587



587x  
6322819

**Customer Service**  
**Kundenservice**  
**Service Consommateurs**  
**Servicio Al Consumidor**

**LEGO.com/service or dial**



**: 00800 5346 5555**

**: 1-800-422-5346**



