

Mi Air Purifier 3C

User Manual



WARNING

- When the power cord is damaged, it must be replaced with a genuine power cord purchased from the manufacturer or after-sales service department.
- This appliance can be used by children aged from 8 years and above and persons with reduced physical, sensory or mental capabilities or lack of experience and knowledge if they have been given supervision or instruction concerning use of the appliance in a safe way and understand the hazards involved.
- Children shall not play with the appliance. Cleaning and user maintenance shall not be made by children without supervision.

Precautions

- Moving** · Turn off and unplug the purifier before moving it.
-
- Installation** · The purifier cannot turn on when the fan grille and the filter compartment cover are not installed properly.
· Maintain a distance of at least 20 cm between the air inlets and walls or other objects.
· The purifier must be placed on firm and flat floor.
-
- Cleaning** · Prior to cleaning or other maintenance, the appliance must be disconnected from the supply mains.
· Frequently remove dust, hair, and other particles from the outer mesh screen of the filter, so as to reduce the chance of bacteria growth.
· Remove dust, hair, and particles from the purifier's air inlets to prevent a reduction of air intake.
· Cover the air outlet to prevent dust, hair, and other particles from falling in when the purifier is left unused for a long time.
-
- Power Supply** To avoid fire, electric shocks, or other damage, use the power cord and electrical outlet as instructed below:
· Do not excessively pull, twist or bend the power cord, as this may expose or break the cord's core.
· The power cord must be plugged into a suitable electrical outlet.
· Use the power cord that is provided with the purifier, do not use any third party power cords.
· Always unplug the purifier before carrying out maintenance to or moving the air purifier.
-
- During Use** · Immediately stop using the purifier when it makes unusual sounds, gives off bad odors, overheats, or its fan rotates irregularly.
· Do not stick your fingers or foreign objects into the protective parts, movable parts, air inlets, or air outlets.
· Keep objects such as hairs or fabrics away from the purifier to avoid blocking the air inlets or air outlets.
· Do not sit on, lean on or tilt the purifier.
· When using in conjunction with gas-fueled appliances (such as gas stoves, gas heaters), please ventilate sufficiently to avoid carbon monoxide poisoning.
· Do not pour liquids, nor throw powders or other small substances into the purifier's air outlet.
-
- Usage Restrictions** Do not use the purifier in the following circumstances, as they may result in electric shocks, fire, or other damage:
· Near open flames, such as candles, incense burners, stoves, fireplaces, cigarettes, firecrackers, lighters, multi-purpose torches, candle lighters, or fire pans.
· Near appliances that generate high temperatures, such as electric heaters, fan heaters, electric foot warmers, electric stoves, electric irons.
· Make sure no inflammable objects get into the purifier.
· In unstable locations where the purifier can easily fall over.
· In environments that are extremely hot, humid, or damp, such as bathrooms.

Product Overview

Read this manual carefully before use, and retain it for future reference

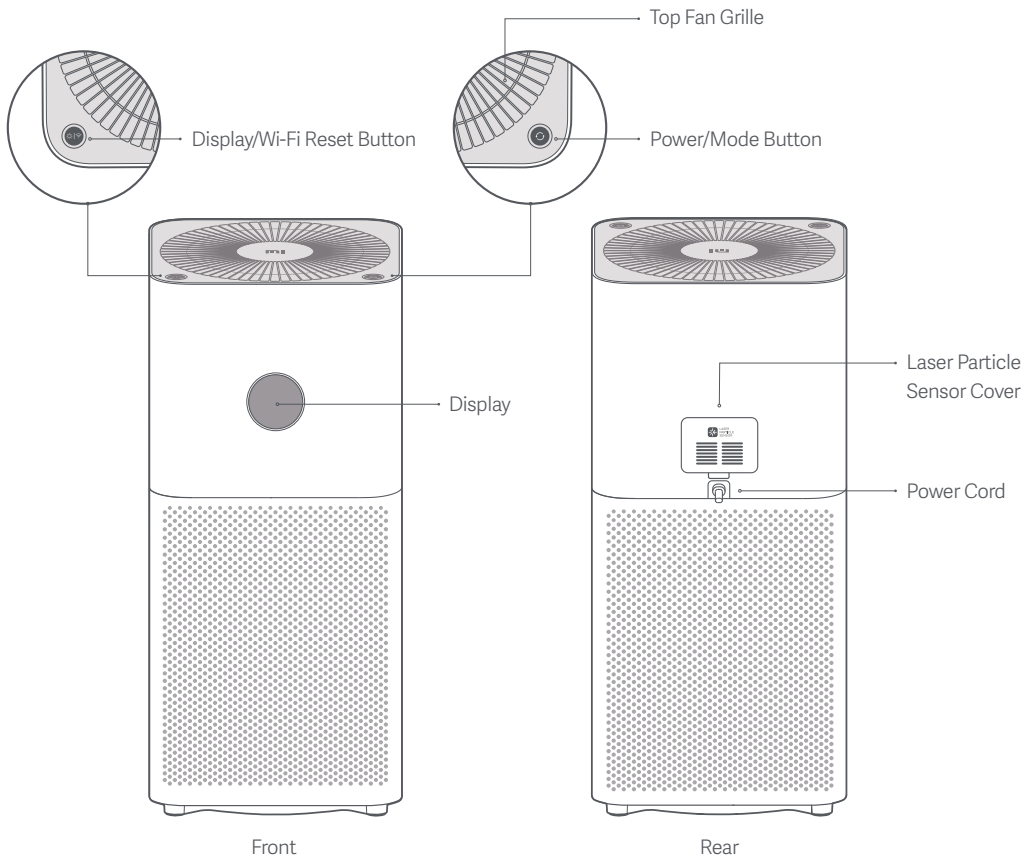

How to Use

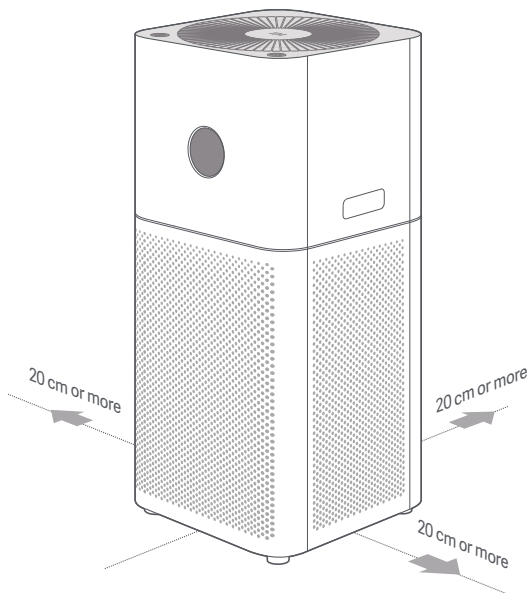

Place the purifier in a suitable location

For optimum performance, maintain the recommended distance between air inlets and walls or other obstacles.

Note: it is recommended to close doors and windows for better filtering when using the purifier.

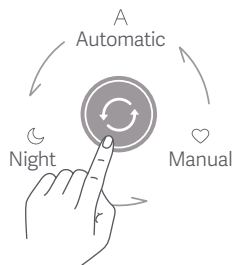

Power / Mode Button

Press the button to turn the air purifier on; press and hold the button for 2 seconds to turn it off. Press the button to switch mode when the air purifier is working.

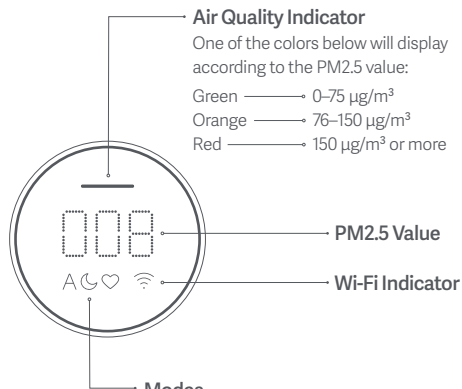

Air Quality Indicator

One of the colors below will display according to the PM2.5 value:

Green — 0-75 µg/m³

Orange — 76-150 µg/m³

Red — 150 µg/m³ or more

PM2.5 Value

Wi-Fi Indicator

Modes

A Automatic: Automatically switch modes according to the indoor air quality.

🌙 Night: Ultra-low noise for a comfortable sleeping environment.

❤️ Manual: Set and save the coverage area and the purifying efficiency in the app.

Replace the Filter

⚠ Make sure to turn off the air purifier and disconnect power before replacing the filter.

Note: To avoid injuries, do not stick your fingers in between the top and the bottom part when opening or installing the filter compartment.

1 Opening the filter compartment

Press and hold the buttons (as in the figure) to remove the top part of the purifier in order to open the filter compartment.

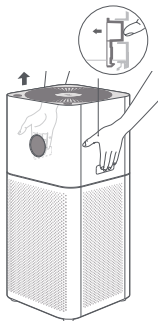

2 Removing the filter

Remove the old filter.

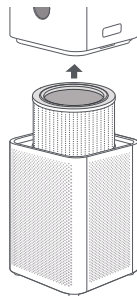

3 Installing the filter

Insert the filter from the top in order to install it in the correct position, and install the top part of the purifier onto the filter compartment.

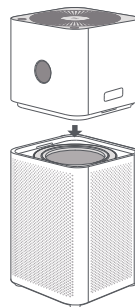

4 Resetting the filter

When the air purifier is in standby mode, press and hold the Power/Mode button for six seconds until the air quality indicator lights up in green for one second. Once you hear three beeps, the filter has been reset successfully.

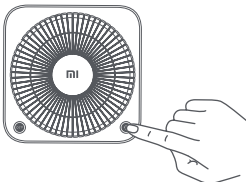

5 Resetting Wi-Fi

If your phone is unable to connect with the purifier, simultaneously press and hold the Power/Mode and the Display/Wi-Fi Reset buttons for five seconds. Once you hear a beep, the Wi-Fi connection has been reset successfully.

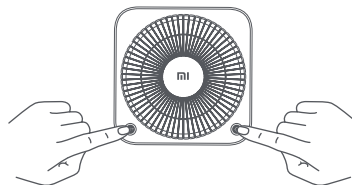

Note: It is recommended to replace the filter every 6–12 months. When the filter needs to be replaced, the indicator light will blink red once the purifier is turned on. To ensure your purifier properly works and purifies, please visit www.mi.com to purchase a genuine Mi filter.

Connect with Mi Home / Xiaomi Home App

This product works with Mi Home / Xiaomi Home app*. Control your device with Mi Home / Xiaomi Home app.

This product works with Mi Home / Xiaomi Home app *. Control your device, and interact it and other smart home devices with Mi Home / Xiaomi Home app.

Scan the QR code to download and install the app. You will be directed to the connection setup page if the app is installed already. Or search "Mi Home / Xiaomi Home" in the app Store to download and install it.

Open Mi Home / Xiaomi Home app, tap "+" on the upper right, and then follow prompts to add your device.

* The app is referred to as Xiaomi Home app in Europe (except for Russia). The name of the app displayed on your device should be taken as the default.



Note: The version of the app might have been updated, please follow the instructions based on the current app version.

Care & Maintenance

▲ Make sure to turn off the air purifier and disconnect power before cleaning.

Cleaning the air purifier

To ensure your purifier works and purifies properly, use a vacuum cleaner or soft cloth to remove any dust clinging to air holes or housing walls.

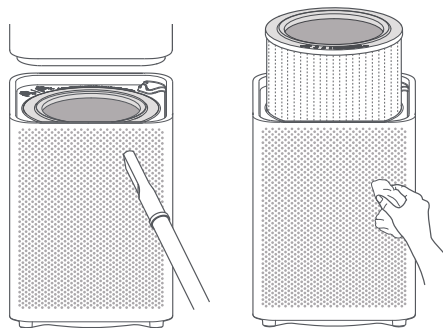

Cleaning the laser particle sensor

Use a non-sharp tool to open the cover of the laser particle sensor, then use an air blow gun or hair dryer to clean the sensor and the filter on the cover, as illustrated in the figure.

Note: Do not use hot air.

The filter in the filter compartment can be cleaned with water, please reinstall it after it is thoroughly dry.

Note: It is forbidden to directly rinse or spray the purifier with water. Do not wipe the purifier with a soaking wet cloth to prevent water from getting into it.

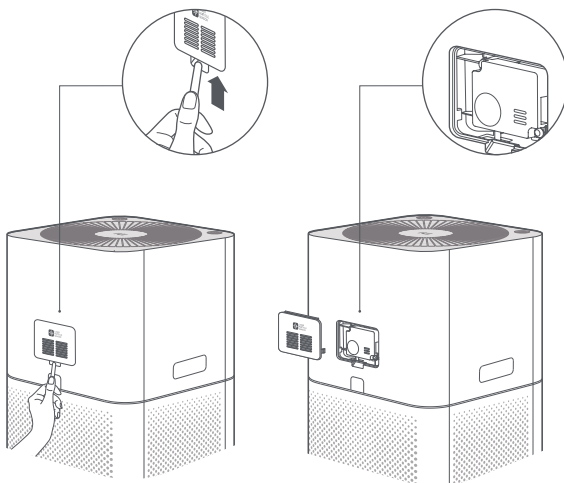

Specifications

Name	Mi Air Purifier 3C	Rated Voltage	100-240 V~	Model	AC-M14-SC
Rated Frequency	50/60 Hz	Rated Power	29 W	Clean Air Delivery Rate (CADR Particles)	320 m ³ /h *
Formaldehyde Clean Air Delivery Rate (CADR Formaldehyde)	60 m ³ /h	Particle Purification Efficiency	High	Formaldehyde Purification Efficiency	High
Dimensions	240 x 240 x 520 mm	Network Standby Power Consumption	< 2.0 W	Net Weight	Approx. 4.6 kg
Noise Level	≤61 dB(A)	Color	White	Area Efficiency	106 m ² /h
Wireless Connectivity	Wi-Fi IEEE 802.11 b/g/n 2.4 GHz				
RF Specification: Wi-Fi 2.4 G (2400 - 2483.5 MHz), Max. RF Output Power: <20 dBm Under normal use of condition, this equipment should be kept a separation distance of at least 20cm between the antenna and the body of the user.					

*Tested for particulate matter by third party lab as according to GB/T 18801-2015

Regulatory Compliance Information

Europe — EU declaration of conformity

 Hereby, Beijing Smartmi Electronic Technology Co., Ltd. declares that the radio equipment type AC-M14-SC is in compliance with Directive 2014/53/EU. The full text of the EU declaration of conformity is available at the following internet address:
<http://www.mi.com/global/service/support/declaration.html>

WEEE Disposal and Recycling Information



All products bearing this symbol are waste electrical and electronic equipment (WEEE as in directive 2012/19/EU) which should not be mixed with unsorted household waste. Instead, you should protect human health and the environment by handing over your waste equipment to a designated collection point for the recycling of waste electrical and electronic equipment, appointed by the government or local authorities. Correct disposal and recycling will help prevent potential negative consequences to the environment and human health. Please contact the installer or local authorities for more information about the location as well as terms and conditions of such collection points.

Illustrations of the product, accessories, and user interface in the user manual are for reference purposes only. The actual product and functions may vary due to product enhancements.

WARRANTY NOTICE

THIS WARRANTY GIVES YOU SPECIFIC RIGHTS, AND YOU MAY HAVE OTHER RIGHTS CONVEYED BY LAWS OF YOUR COUNTRY, PROVINCE OR STATE. INDEED, IN SOME COUNTRIES, PROVINCES OR STATES, CONSUMER LAW MAY IMPOSE A MINIMUM WARRANTY PERIOD. OTHER THAN AS PERMITTED BY LAW, XIAOMI DOES NOT EXCLUDE, LIMIT OR SUSPEND OTHER RIGHTS YOU MAY HAVE. FOR A FULL UNDERSTANDING OF YOUR RIGHTS WE INVITE YOU TO CONSULT THE LAWS OF YOUR COUNTRY, PROVINCE OR STATE.

1.LIMITED PRODUCT WARRANTY

XIAOMI warrants that the Products are free from defects in materials and workmanship under normal use and use in accordance with the respective Product user manual, during the Warranty Period.

The duration and conditions related to the legal warranties are provided by respective local laws. For more information about the consumer warranty benefits, please refer to Xiaomi's official website <https://www.mi.com/en/service/warranty/>.

Xiaomi warrants to the original purchaser that its Xiaomi Product will be free from defects in materials and workmanship under normal use in the period mentioned above.

Xiaomi does not guarantee that the operation of the Product will be uninterrupted or error free.

Xiaomi is not liable for damages arising from non-compliance with the instructions related to the use of the Product.

2.REMEDIES

If a hardware defect is found and a valid claim is received by Xiaomi within the Warranty Period, Xiaomi will either (1) repair the product at no charge, (2) replace the product, or (3) refund the Product, excluding potential shipping costs.

3.HOW TO OBTAIN WARRANTY SERVICE

To obtain warranty service, you must deliver the Product, in its original packaging or similar packaging providing an equal degree of Product protection, to the address specified by Xiaomi. Except to the extent prohibited by applicable law, Xiaomi may require you to present proofs or proof of purchase and / or comply with registration requirements before receiving warranty service.

4.EXCLUSIONS AND LIMITATIONS

Unless otherwise stipulated by Xiaomi, this Limited Warranty applies only to the Product manufactured by or for Xiaomi and identifiable by the trademarks, trade name or "Xiaomi" or "Mi" logo.

The Limited Warranty does not apply to any (a) Damage due to acts of nature or God, for example, lightning strikes, tornadoes, flood, fire, earthquake or other external causes; (b) Negligence; (c) Commercial use; (d) Alterations or modifications to any part of the Product; (e) Damage caused by use with non-Xiaomi products; (f) Damage caused by accident, abuse or misuse; (g) Damage caused by operating the Product outside the permitted or intended uses described by Xiaomi or with improper voltage or power supply; or (h) Damage caused by service (including upgrades and expansions) performed by anyone who is not a representative of Xiaomi.

It is your responsibility to backup any data, software, or other materials you may have stored or preserved on the product. It is likely that the data, software or other materials in the equipment will be lost or reformatted during the service process, Xiaomi is not responsible for such damage or loss.

No Xiaomi reseller, agent, or employee is authorized to make any modification, extension, or addition to this Limited Warranty. If any term is held to be illegal or unenforceable, the legality or enforceability of the remaining terms shall not be affected or impaired.

Except as prohibited by laws or otherwise promised by Xiaomi, the after-sales services shall be limited to the country or region of the original purchase.

Products which were not duly imported and/or were not duly manufactured by Xiaomi and/or were not duly acquired from Xiaomi or a Xiaomi's official seller are not covered by the present warranties. As per applicable law you may benefit from warranties from the non-official retailer who sold the product. Therefore, Xiaomi invites you to contact the retailer from whom you purchased the product.

The present warranties do not apply in Hong Kong and Taiwan.

5.IMPLIED WARRANTIES

Except to the extent prohibited by applicable law, all implied warranties (including warranties of merchantability and fitness for a particular purpose) will have a limited duration up to a maximum duration of this limited warranty. Some jurisdictions do not allow limitations on the duration of an implied warranty, so the above limitation will not be applied in these cases.

6.DAMAGE LIMITATION

Except to the extent prohibited by applicable law, Xiaomi shall not be liable for any damages caused by accidents, indirect, special or consequential damages, including but not limited to loss of profits, revenue or data, damages resulting from any breach of express or implied warranty or condition, or under any other legal theory, even if Xiaomi has been informed of the possibility of such damages. Some jurisdictions do not allow the exclusion or limitation of special, indirect, or consequential damages, so the above limitation or exclusion may not apply to you.

7.XIAOMI CONTACTS

For customers, please visit the website: <https://www.mi.com/en/service/warranty/>
The contact person for the after-sale service may be any person in Xiaomi's authorized service network, Xiaomi's authorized distributors or the final vendor who sold the products to you. If in doubt please contact the relevant person as Xiaomi may identify.

Manufactured by: Beijing Smartmi Electronic Technology Co., Ltd.
(a Mi Ecosystem company)
Address: Room 201-203, Unit 6, Building A, No. 66, Zhufang Road, Qinghe, Haidian District, Beijing
For further information, please go to www.mi.com
For detailed e-manual, please go to www.mi.com/global/service/userguide

Importer:
Beryko s.r.o.
Na Roudné 1162/76, 301 00 Plzeň
www.berko.cz